

# Design and Fabrication of Contactless Magnetic Transmission

Pranav Rane <sup>1</sup>, Devanand Otavkar <sup>2</sup>, Abhishek Joshi<sup>3</sup>, Darshan Sawant<sup>4</sup>, Yogesh Dhanawde<sup>5</sup>

<sup>1-4</sup>UG student, Mechanical Engineering Department, SSPM's College of Engineering, Maharashtra, India

<sup>5</sup>Assistant Professor, Dept. of Mechanical Engineering, S.S.P.M College, Maharashtra, India

\*\*\*

**Abstract** - Neodymium magnets are incredible magnets which are around multiple times more grounded than typical magnets utilized in speakers. These attractive outfitted perpetual magnet machines guilefully join the idea of attractive equipping into the lasting magnet machines, prompting accomplish low-speed high-force direct-drive activity. Riggings and gearboxes are broadly utilized for speed change and force transmission in different mechanical applications. It is notable that the mechanical rigging has a high force thickness, however experiences some inalienable issues, for example, contact grating, vibration and unwavering quality are of extraordinary concern. So as to dodge these kinds of issues we are utilizing attractive cross section gears. That is the riggings are fit along with the assistance of attractive power of fascination without connecting. By utilizing such sort of equipping frameworks we can diminish the mileage that are normally observed in mechanical spike gear frameworks and the attractive apparatuses works easily with no stable and the fundamental bit of leeway of attractive outfitting is it won't get warmed as long as it works. We are utilizing high force uncommon earth neodymium magnets to make gears.

**Keywords:** Contactless Magnetic Transmission, Magnetic Drive Transmission

## 1. INTRODUCTION

Riggings and gearboxes are broadly utilized for speed change and force transmission in different mechanical just as car applications. The mechanical rigging has a high force thickness, however Experiences some innate issues, for example, contact grinding, commotion, warmth, vibration and dependability are of incredible concern. Because of this gearbox get harmed and furthermore productivity of framework get reduces the working standard of attractive apparatus is non-contact power transmission.

A Contactless transmission is a transmission framework that moves the force from one shaft to another by utilizing attractive field, instead of physical mechanical contact. The Attractive riggings works by utilizing the force created by perpetual magnets which frame the attractive apparatuses to communicates the movement.

### 1.1 Principle of Operation

The working standard of attractive apparatus is non-contact power transmission. It chips away at the guideline of

attraction. Attractive apparatuses make the attractive field of amazing lasting magnets to turn the mating parts.

These ground-breaking magnets are neodymium magnets which are put in interchange shafts along the periphery of the apparatus.

Development of the apparatuses will be accomplished by the attractive power created by the fascination d shock of the two inverse shafts (S N Poles) of the magnets.

### 1.2 Methodology

In our endeavor development and power transmission occurs by appealing field made by unending magnets. Directly off the bat motor is related with driver gear through belt drive. Permanent magnets of driver makes appealing field due to which driven apparatus having never-ending magnets in like manner starts rotating. With the objective that power is communicated beginning with one shaft then onto the following by alluring mechanical assemblies.

Control Parameters of the System:

1. The main player of the framework for example electric engine.
2. The quality of perpetual magnets utilized in coupling.
3. The hole between the two associating shafts for example space between couplings as it assumes significant job in light of electromagnets qualities go.

## 2. WORKING

A 230 volt AC input power gracefully is utilized to turns over the engine. At the point when engine turns over pivoting, it communicates the force to the info shaft by means of belt drive. Shaft is upheld by two platform bearing, opposite finish of shaft comprises of number of magnets appended to the roundabout surface of shaft. A roundabout metal circle is fitted on center of yield shaft which comprise of number of neodymium magnets at equivalent good ways from focus of metal plate. There is a little hole between the information and yield shaft, both is isolated by little separation and not in contact with one another. When inverse posts of magnets are before one another then there is a fascination between two magnets. At the point when info shaft turns then the

following two posts pull in one another. This wonder is constantly happens. Because of this fascination of magnets the info shaft communicates the ability to the yield shaft. Since yield shaft is fixed to the wheels of vehicle along these lines it sends the ability to the haggles begins moving towards.

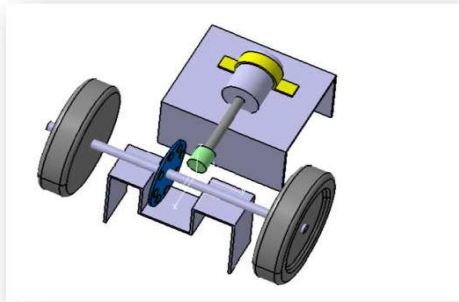

**Chart -1:** Isometric View

## 2.1 Result and discussion

- Reduced maintenance and improved reliability.
- Lubrication free.
- Higher efficiency than conventional gears.
- Precise peak torque transmission and inherent overload protection.
- Physical isolation between input and output shafts.
- Inherent anti-jamming transmission
- Allows for misalignment/vibration of shafts.
- Very low acoustic noise and vibration.

## 3. CONCLUSIONS

- Our framework effectively exhibits the advantages of contactless force transmission like, higher transmission productivity, diminished force misfortune, no grating as it is contactless and subsequently no wear of parts and framework so more prominent existence of framework.
- They are especially valuable when it is important to guarantee a severe, physical detachment between the drive and driven side.

- For higher force appraisals an attractive apparatus will be littler, lighter and lower cost than a mechanical rigging. Since there is no mechanical contact between the moving parts there is no wear and oil isn't needed

## REFERENCES

- [1] C.G Armstrong: "Power Transmitting Device ", Unites States Patent Office, No. 687, 292, 26th Nov 1901.
- [2] H.T Faus: "Magnetic Gearing ", Unites States Patent Office, No. 2, 243, 555, 27th May 1941.
- [3] T. B Martin, JR: "Magnetic Transmission ", Unites States Patent Office, No. 3, 378, 710, 16th April 1968
- [4] K. Atallah et al: A Novel High Performance Magnetic Gear, IEEE Transactions on Magnetics, Vol. 37, No. 4, pp. 2844-2846, 2001
- [5] K. T. Chau and C. C. Chan, "Emerging energy-efficient technologies for hybrid electric vehicles," Proc. IEEE, vol. 95, no. 4, pp. 821-835, Apr. 2007