

FAULT IDENTIFICATION AND REMOTE OPERATION OF RECEIVING SUBSTATION AND AUXILIARY SUBSTATION USING IOT

Rajat Sangolkar¹, Prof. R.M. Bhombe², Prof. A.S. Welankiwar³

¹⁻³Department of Electrical Engineering, Guru Nanak Institute of Engineering and Technology, Nagpur, Maharashtra, India.

ABSTRACT: A substation is a part of an electrical generation, transmission, and distribution system. Early electrical substations required manual switching or adjustment of equipment, and manual collection of data for load, energy consumption, and abnormal events. As the complexity of distribution networks grew, it became economically necessary to automate supervision and control of substations from a centrally attended point, to allow overall coordination in case of emergencies and to reduce operating costs. Early efforts to remote control substations used dedicated communication wires, often run alongside power circuits. Power-line carrier, microwave radio, fibre optic cables as well as dedicated wired remote-control circuits have all been applied to Supervisory Control and Data Acquisition (SCADA) for substations. The development of the microprocessor made for an exponential increase in the number of points that could be economically controlled and monitored. Today, standardized communication protocols such as DNP3, IEC 61850 and Modbus, to list a few, are used to allow multiple intelligent electronic devices to communicate with each other and supervisory control centres. In this paper the various parameter for fault identification and remote operation are performed with the help of the IOT (Internet Of Things). A module of sensors and transducers monitors the parameters and also check for the healthiness of the system. The implementation of this type of schemes will increase the working efficiency of the system by continuously monitoring the healthiness of parameters of the system and also to identify the faulty part as well as the reason of the fault in the system directly within a short period of time.

Keywords: - Substation Automation, Fault Identification, Parameter Monitoring, Parameter Controlling, Internet of Things.

I. INTRODUCTION

The aim of the electrical power system is to generate and supply the power electric to the user. To construct and to manage the energy to the utilization point, it must be had reliability and economy. Since the power system involved in the generation, transmission, distribution, it needs protection to avoid damage to electrical appliances and the Personal's life. In electrical engineering, the power system is one of the exclusive

fields which deal with shortest and the fastest time to trip and isolate the faulty area in the power system so that the fault does not affect the system directly. As a result, the system remains their stability and reliability. The essential elements of protection are sensors to identify the fault condition and a device to initiate tripping signal to the Circuit breaker. The protection system must fulfil the requirements of rapidly and automatically disconnect the faulty section of the power network, and minimize disconnection or interruption of power supply to the consumer. The ability of tripping for circuit breakers are reliability, selectivity, sensitivity, speed and stability.

Considering the Metro Rail System, the Receiving substations (RSS) are the stations that receive the electrical power from the grid. The electrical power received here are in high voltage form i.e. 132kv or 220kv etc. In the receiving substation the voltage is stepped down into 33kv or into any other required value for the utility. Now this 33KV voltage is transmitted and then stepped down further into 415v and is used for the different utility. The process of stepping down the voltage from 33kv into 415v is done in the Auxiliary Substation (ASS). This RSS and ASS consists of the various equipment such as incoming lines, outgoing lines, transformers, post & string insulators, circuit-breakers, isolators, earthing switches, surge arresters, CTs, VTs, neutral grounding equipment, etc. To control and monitor all this equipment a SCADA system is used in the substations. The protection system employed in these substations is for- overcurrent, earth fault current, over voltage, under voltage, emergency tripping with the help of emergency push button, etc. Here, our main objective is to identify the type of fault and thus the exact location with the reason of tripping of the breaker can be identified.

II. LITERATURE SURVEY

Significant efforts have been employed for the protection and controlling of the substations from last two decades and many techniques have been proposed. Thus, a brief description with their advantages and disadvantages are described in the section below.

- a. According to Star Control INC., Florida. And according to the global forecast report, 2020; it is founded that the SCADA system comprises of

nearly 45%-55% of the total cost of the particular Station [1].

- b. There are some successful examples such as PLC SCADA based fault detection and protection system is implemented which provides the web based user interface for remote control and monitoring was developed and presented online to users but the main disadvantage is cost this system are more costlier.
- c. Apart from this the SCADA system requires a complex circuitry from the feeder control panels to the RTU and then from RTU to telemetry system and then finally ends in the control centre from which the substation is monitored and controlled. All this process requires a long length of FO cables laying (underground) in the system which ultimately results on the complex circuitry of the system and also the cost increases [2]. In this particular type of system when communication fail occurs, it is very difficult to identify the location and reason for the communication failure.
- d. International Journal of Recent Technology and Engineering (IJRTE) ISSN: 2277-3878, Volume-7, Issue-5S3, February 2019. Substation Monitoring and Control based on Microcontroller Using IOT shows that how the substation monitoring and control using microcontroller and IOT can improve the quality of power transferred and provide the uninterrupted power supply. Apart from this a real time monitoring of different parameters can be done which can ensure safety to the substation and its equipment [3], [4].
- e. Future Distribution Substation - IoT connectivity integrated -By Siemens. This shows the Future Distribution Substation from Siemens, with an integrated IoT connection. For preparing the distribution grid for the challenges of the transition to a new energy mix. The smart secondary substation represents future-viable power distribution. It focuses on digitalization, decarbonization, and decentralization. Medium- and low-voltage power grids need to handle changes due to the increasing integration of distributed infeed of renewable energy and growing electromobility in private transportation. While more and more of the necessary connection capacity can be provided through grid expansion, the effects of changing energy flow direction, load fluctuations, and voltage range compliance can only be managed with intelligent solutions [5].

III. SYSTEM ANALYSIS

The proposed system is having three parts-

1. Monitoring of Breakers at Substation.
2. Controlling the status of Breakers at Substations.
3. Fault Identification at Substations.

The status of the Breaker is taken to the smart electronic device (Relay) with the help of various physical connections between the relay and the breaker. Later on, this smart electronic device communicates with the IOT interference device. This IOT interference device communicate with another interference device which is present in the Operation Control Centre. The User of the Substation operates the whole system from the Operation Control Centre itself. Apart from this the various status of the substation are reflected in the Operation Control Centre. And thus there is two way communication between the substation and the operation control centre. The block diagram of the system described is as follows.

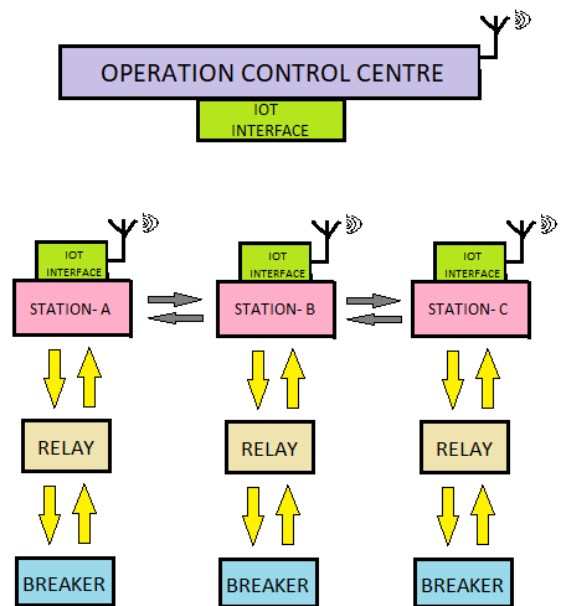

FIG 1 - Block Diagram IOT Based Substations.

IV. SYSTEM DESCRIPTION

A. System Block Diagram

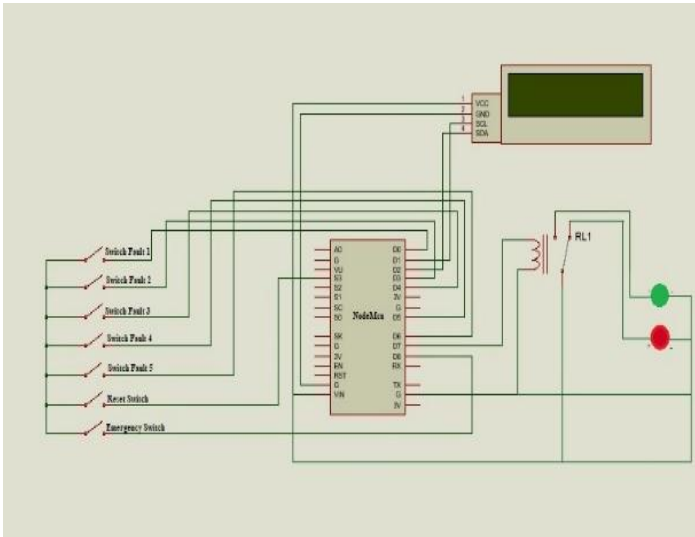

FIG 2- Demo Model of The IOT Based Substation.

For this model ESP8266 micro-controller is used. The ESP8266 is a self-contained Wi-Fi networking solution offering as a bridge from existing micro-controller to Wi-Fi and is also capable of running self-contained applications.

When the fault occurs in the system, the parameters i.e. voltage and current of the system gets changed from its normal value. These values of parameters get sensed by the current transformers and the voltage transformers employed in the system. When the fault occurs the current and the voltage transformer creates a signal which is fed to the microcontroller. Here the microcontroller is programmed in such a way that each and every fault that occurs in the system gets denoted in the microcontroller. Let the Fault-1 as overcurrent fault, thus if the overcurrent fault occurs in the system, the microcontroller senses this fault and the information of this fault is reflected on the LCD screen as well as on the user's screen present in the Operation Control Centre. Likewise, the other faults can also be denoted and reflected on the user's screen. Therefore, the user gets the exact location and information of the fault that occurs in the system, which further helps in the rectification of the fault within the short period of time.

Here two LEDs are also used, one is green which shows that the breaker is in open condition and other is red which shows that the breaker is in closed condition. Thus, the status of the breaker can be viewed physically on the field as well as on the user's screen the status is reflected. Apart from this an emergency push button is also provided on the breaker itself. In the case of any

abnormality viewed in the breaker the breaker can be switched off physically in the field itself.

B. SOFTWARE DESCRIPTION

For this Adafruit.io is used. Adafruit.io is a cloud service meant primarily for storing and then retrieving data. It displays data in real time.

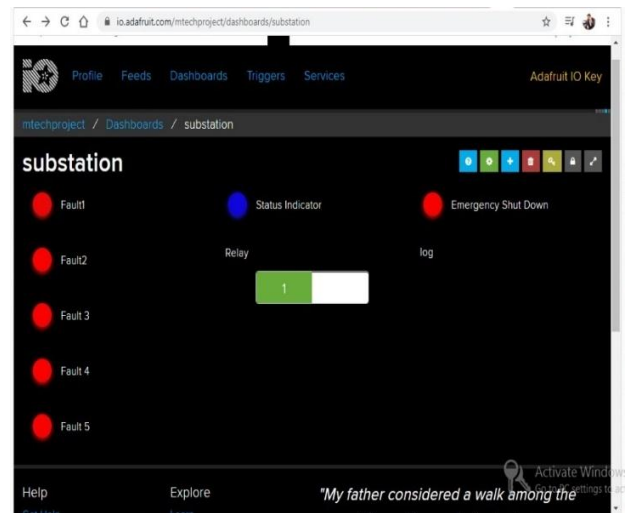

FIG 3 - Screen Shot of The Web-Page Present in the Operation Control Centre.

As shown in the screen shot of the web page above, the status of the breaker in the substation is shown on the user's screen. When the fault occurs the name and type of the fault is also shown in the user's screen. A status of the emergency push button is also taken on the screen. Thus, the user gets the full information of the system on the Operation Control Centre.

C. HARDWARE DESCRIPTION

1. ESP8266 NodeMCU WiFi Devkit

The ESP8266 is the name of a micro controller designed by Espressif Systems. The ESP8266 itself is a self-contained WiFi networking solution offering as a bridge from existing micro controller to WiFi and is also capable of running self-contained applications. This module comes with a built-in USB connector and a rich assortment of pin-outs. With a micro USB cable, you can connect NodeMCU devkit to your laptop and flash it without any trouble.



FIG 4 - ESP8266 NodeMCU WiFi Devkit

2. LCD

LCD (Liquid Crystal Display) screen is an electronic display module and find a wide range of applications. A 16x2 LCD display is very basic module and is very commonly used in various devices and circuits. These modules are preferred over seven segments and other multi segment LEDs. The reasons being: LCDs are economical; easily programmable; have no limitation of displaying special & even custom characters (unlike in seven segments), animations and so on.

A 16x2 LCD means it can display 16 characters per line and there are 2 such lines. In this LCD each character is displayed in 5x7 pixel matrix. This LCD has two registers, namely, Command and Data.

The command register stores the command instructions given to the LCD. A command is an instruction given to LCD to do a predefined task like initializing it, clearing its screen, setting the cursor position, controlling display etc. The data register stores the data to be displayed on the LCD. The data is the ASCII value of the character to be displayed on the LCD. Fig10 shows 16x2 LCD.



FIG 5 - 16x2 LCD

3. RL1 RELAY

This simple board contains a single 24V DC relay, which can be used for any extra low voltage switching applications. It has two changeover contacts, an LED indicator to show when the coil is energised and a

polarising diode to prevent damage to the power source by reverse polarity connection. The contacts are suitable for switching a maximum of 30V DC and 2 Amps. The current consumption of the unit when operated from a 24V supply is approximately 25mA. The PCB has four 4mm mounting holes, which will accept the self-adhesive standoffs supplied.



FIG 6 - RL1 Relay

V. CONCLUSIONS

1. The fault identification and operation of the receiving substation and the auxiliary substation using IOT gives us the more efficient, secure and reliable operation of the substations. The IOT devices which are installed on the feeders gives the information of that particular feeder. The information of the fault parameters and the reason of that particular fault is easily traced out with this device. In the Operation Control Centre all this data is made available on the user's screen and the user gets the real time information of the system. If any abnormality occurs in the system the corrective measures can be taken immediately by the user.
2. Apart from all this reliable functions this IOT device is more economical than the SCADA system because it eliminate the various elements of the SCADA system such as LAN cables, Fibre Optics cable, industrial switches, RTU, etc. thus with the reduction of the elements the complexity of the circuit is reduced and the rectification of the faults become more easier.

VI. REFERENCES

1. Star Control Inc, –Integrating Flow Calculation System with SCADA||, Star Control Inc. 11555 Heron Bay Blvd., Coral Springs, Florida 33076, Tel: 954 603 0491, 954 757 2775, Fax: 954 603 0492.

2. Substation Automation Market by Module (IEDS, Communication Network, SCADA System), Offering, Type (Transmission, Distribution), Installation Type (Retrofit & New Installation), Industry & Geography - Global Forecast to 2022.
3. International Journal for Research in Applied Science & Engineering Technology (IJRASET) ISSN: 2321-9653; IC Value: 45.98; SJ Impact Factor: 6.887 Volume 6 Issue V, May 2018- Available at www.ijraset.com ©IJRASET: All Rights are Reserved 2537 Substation Monitoring System Amol Ram Kate , Girish Baban Dongare , Krishana Maroti Janwade , Payal Burande, Narendra P. Zinjad, UG Students, Assistant Professor Department of Electrical Engineering, D. Y. Patil Institute of Engineering & Technology, Pune, India.
4. International Journal for Research in Applied Science & Engineering Technology (IJRASET) ISSN: 2321-9653; IC Value: 45.98; SJ Impact Factor: 6.887 Volume 6 Issue V, May 2018- Available at www.ijraset.com ©IJRASET: All Rights are Reserved 2537 Substation Monitoring System Amol Ram Kate , Girish Baban Dongare , Krishana Maroti Janwade , Payal Burande, Narendra P. Zinjad, UG Students, Assistant Professor Department of Electrical Engineering, D. Y. Patil Institute of Engineering & Technology, Pune, India.
5. <https://www.youtube.com/watch?v=ja5fjNcaJ4>
<https://new.siemens.com/global/en/products/energy/mediumvoltage/systems/8djh.html>
6. K. Hak-Man, L. Jong-Joo, and K. Dong-Joo, "A platform for smart substation," In Future Generation Communication and Networking (FGCN 2007), IEEE, vol. 1, 2007, pp. 579-582.
7. J. Kester et al., "A Smart MV/LV-station that improves power quality, reliability and substation load profile," 20th International Conference and Exhibition on Electricity Distribution - Part 1 (CIRED 2009), Prague, Czech Republic, 8-11 June, 2009.
8. J. Heckel, "Smart substation and feeder automation for a smart distribution grid," 20th International Conference and Exhibition on Electricity Distribution - Part 1 (CIRED 2009), Prague, Czech Republic, 8-11 June, 2009.
9. H. Spack et al., "Intelligent Transformer Substations in Modern Medium Voltage Networks as Part of "Smart Grid", 7th Mediterranean Conference and Exhibition on Power Generation, Transmission, Distribution and Energy Conversion, Agia Napa, Cyprus, Paper No. MED10/240, 7-10 November, 2010.
10. D. Xu Li, W. He, and S. Li, "Internet of things in industries: A survey," IEEE Transactions on industrial informatics vol. 10, no. 4, 2014, pp. 2233-2243.