

38GHz/61GHz DUAL-BAND PROXIMITY COUPLED FED HEXAGONAL MICROSTRIP PATCH ANTENNA WITH SPLIT SQUARE RING SLOTS, TARGETING 5G/6G APPLICATIONS.

MAHESH NARAYAN¹, PROF. K.K.VERMA², HIMANSHU BHUSAN BASKEY³

¹Research scholar, Department of Physics and Electronics Dr. Rammanohar Lohia Avadh University, Ayodhya.U.P, India

²Prof. K.K.Verma Professor, Department of Physics and Electronics Dr. Rammanohar Lohia Avadh University Ayodhya. U.P, India

³Himanshu Bhusan Baskey DMSRDE (DRDO) G.T Road, Kanpur U.P, India

Abstract - This paper presents a 38. GHz / 61GHz, dual-band proximity coupled feed microstrip patch antenna with split square ring slots for future 5G/ 6G applications. The concept of dual split square ring slots (SSRS) has been used in radiating patch to reduce size of the antenna and enhance bandwidth and frequency response. The antenna design consist of patch with dual opposite facing split ring slots, ground having a small rectangular slot and stacked substrates RogersR03003, Rogers RT5880 of dielectric constants 3.0 and 2.2 respectively and Γ -shaped slot etched off in the feed line, sandwiched between the substrates. The proposed antenna resonated at frequencies 38.017GHz and 61.166GHz with return loss -12.044 dB and -21.411dB covering very large band width of the order of 1.69 GHz and 12.775 GHz. The simulation process has been carried out through CST Microwave Studio 2018.The characteristic properties such as Bandwidth, return loss and VSWR have been investigated and analyzed.

Key Words: CST, SSRS, RogersR03003 and Rogers RT5880.

1. INTRODUCTION

The fifth generation (5G) /sixth generation (6G) cellular network advancement is a significant step towards high speed wireless communication to meet the requirements and genuine demands of the mobile market. The evolution of fifth generation / sixth generation (5G / 6G) cellular phone meshing will bring ubiquitous connectivity for fast compilation, transmission and usage of monolithic volume and variety of data. The mobile industry has observed an amazing and rapid up-growth as , evolution from analog to digital 2G (GSM) , 2G to 3G (WCDMA) , to 3.5 G (HSPA) and further to 4G(LTE and LTE advance) system [1]. However, with an amazing and rapid development in wireless cellular mobile phones devices and services, there are still some challenges which could not be resolved even by 4G, such as spectrum crisis and high energy consumption [2]. The higher frequency bands give to access 5G / 6G cellular network. In view of it, top five candidates of frequency range 24.25GHz – 27.5GHz, 27.5 GHz – 29.5GHz, 37 GHz – 39 GHz and 57GHz – 71 GHz are standardized for 5G / 6G technology [3-5]. In India high band range of 24.5 GHz – 29.5 GHz and 37GHz – 39GHz are being considered to prefer. The proposed antenna design comes under dual frequency range 38GHz –61GHz which corresponds Ka band. In Ka band the data transmission rates are hundred times faster than other bands. Ka band is utilized mainly for RADAR and an experimental communications [6].Therefore, in view of it, modern day world is thinking to utilize Ka band for future space communication [7].

1.1 ANTENNA GEOMETRY AND DESIGN

The circumscribed radius of the radiating hexagonal microstrip patch antenna is 1.434mm and length of each side of the regular hexagonal microstrip patch antenna is 1.5mm .Thickness of radiating hexagonal microstrip patch antenna is 0.036mm. Width (W_1), Length (L_1) and Height (h_1) of the grounded substrate-1“Rogers R03003” are 4.0mm, 6.4mm and 0.6mm respectively. Whereas Width(W_2), Length(L_2) and height (h_2) of the supported and stacked substrate-2” Rogers RT 5880” are 3.0mm,4.8mm and 1.0mm respectively. Width (W) Length (L) and Height (h) of the ground are 4.0mm, 6.4mm and 0.036.To enhance bandwidth and frequency response, a rectangular slot of dimensions 1.0 mm x 1.5 mm is etched off in the ground. Γ -shaped slot of vertical expansion 1.25mm, horizontal expansion 1.50mm and width 0.25mm is etched off in the feed line, sandwiched substrate -1 and substrate-2 as shown in the fig-1 and fig-2.

TABLE -1: DESIGN SPECIFICATION OF PROPOSED ANTENNA

ANTENNA	DIMENSION	VALUE	MATERIAL
HEXAGONAL MICROSTRIP PATCH ANTENNA	SIDE LENGTH OF THE REGULAR HEXAGONAL PATCH	1.5mm	COPPER
	CIRCUMSCRIBED RADIUS OF THE HEXAGONAL PATCH	1.434mm	COPPER
	THICKNESS OF THE PATCH	0.036mm	COPPER
	HEIGHT OF SUBSTRATE -2	1.0mm	ROGERS RT5880
	WIDTH OF SUBSTRATE -2	3.0mm	ROGERS RT5880
	LENGTH OF SUBSTRATE-2	4.8mm	ROGERS RT5880
	HEIGHT OF SUBSTRATE -1	0.6mm	ROGERS R03003
	WIDTH OF SUBSTRATE -1	4.0mm	ROGERS R03003
	LENGTH OF SUBSTRATE-1	6.4mm	ROGERS R03003
	WIDTH OF GROUND	4.0mm	COPPER
	LENGTH OF GROUND	6.4mm	COPPER
	THICKNESS OF GROUND	0.036mm	COPPER
	WIDTH OF RECTANGULAR SLOT	1.0 mm	AIR
	LENGTH OF RECTANGULAR SLOT	1.5mm	AIR
	VERTICAL EXPANSION OF Π -SHAPED SLOT	1.25mm	AIR
	HORIZONTAL EXPANSION OF Π -SHAPED SLOT	1.5mm	AIR
	WIDTH OF VERTICAL AND HORIZONTAL EXPANSIONS OF Π - SHAPED SLOT	0.25mm	AIR

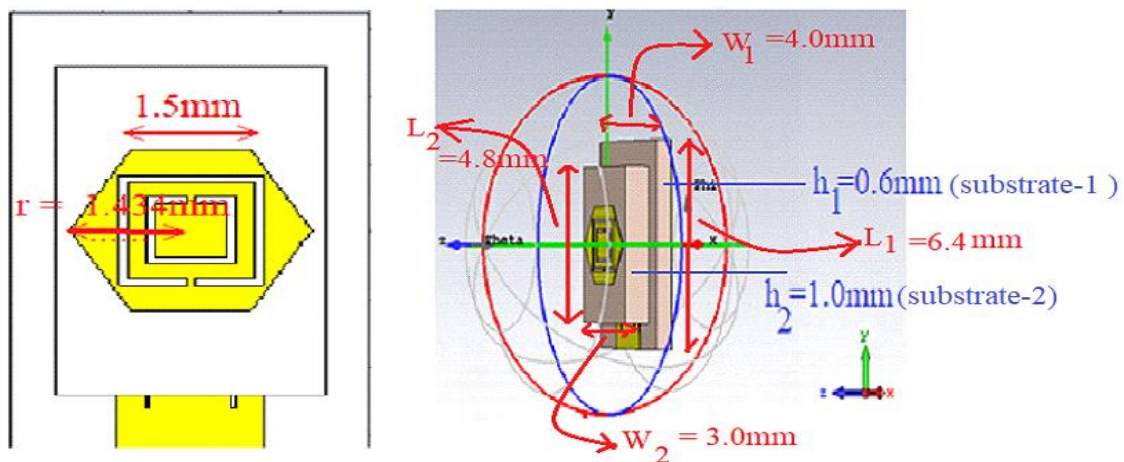

FIG-1: FRONT AND SIDE VIEWS WITH SHOWN DIMENSIONS OF THE PROPOSED ANTENNA

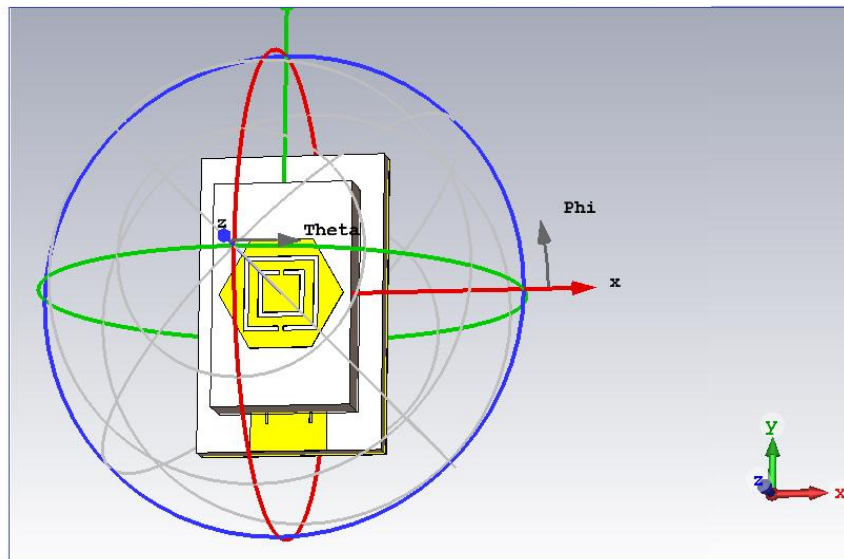

FIG-2: FRONT AND PERSPECTIVE VIEW OF THE PROPOSED ANTENNA SHOWING PATCH WITH SPLIT SQUARE RING SLOTS AND Π ETCHED FEED LINE

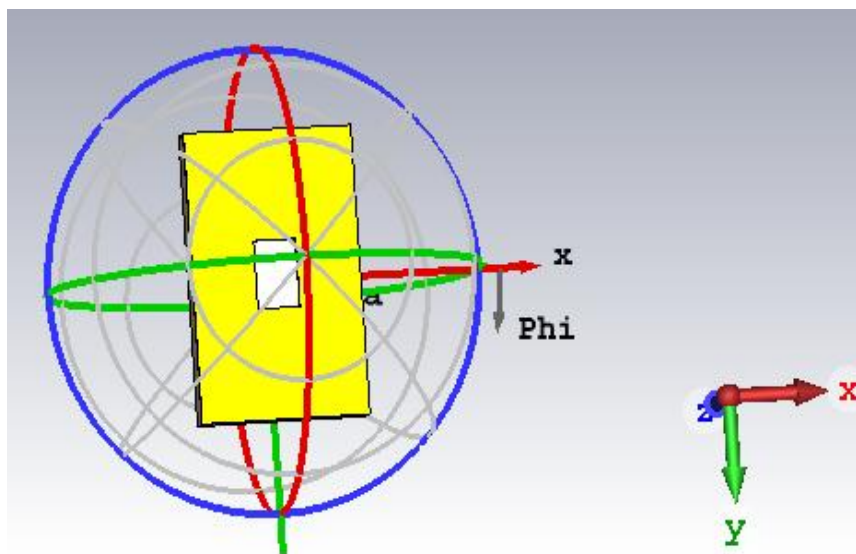

FIG-3: BACK VIEW OF THE PROPOSED ANTENNA SHOWING RECTANGULAR SLOT ON GROUND

2. SIMULATIONS AND RESULTS

After designing the antenna, simulation process has been carried out using CST Microwave Studio 2018. The antenna performance are evaluated in view of return loss, VSWR, gain and directivity. The valid radiating frequency of the antenna is described by the parameters Return loss and VSWR. If the return loss of an antenna for any specific frequency is more than -10dB, it indicates that whatever power fed to antenna out of maximum is rejected. Therefore, for a good radiating patch of an antenna, return loss always should be less than -10 dB and also VSWR should be less than numerical value of 2 for an impedance matching.

(A): RETURN LOSS:

Plots for return loss of the proposed antenna are shown in fig-4. Magnitudes of reflection coefficient have been found to be -12.044dB at resonant frequency 38.017GHz, and -21.411dB at resonant frequency 61.166GHz. At -10dB, the band width have been found 1.69 GHz, which covers 4.45% at resonant frequency 38GHz and 12.775 GHz, which covers 21% at resonant frequency 61GHz.

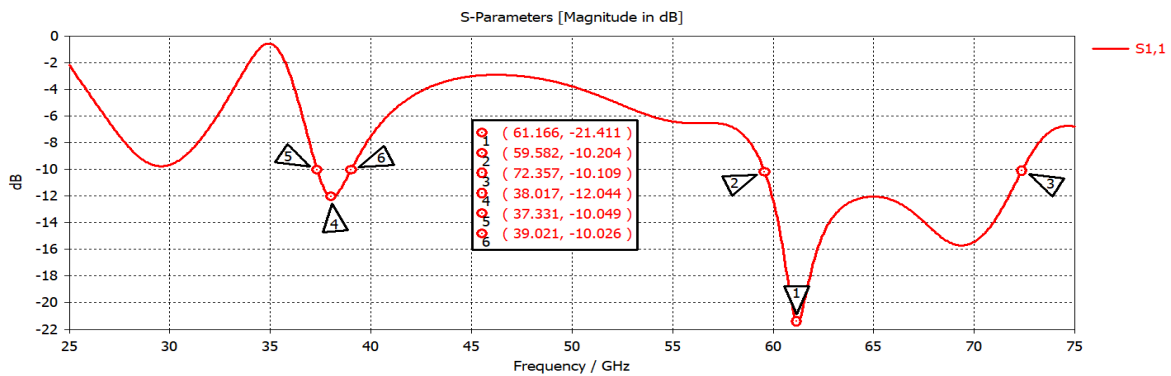

FIG-4: RETURN LOSS PLOT OF THE ANTENNA

(B): VSWR

The magnitude of VSWR for the proposed antenna is shown in fig-5. At resonant frequency 38GHz, it is 1.6661 which is (<2) less than 2, hence it is in good agreement for an impedance matching. At resonant frequency 61GHz, it is 1.1944 which is in good agreement and very close to an ideal value 1, for impedance matching.

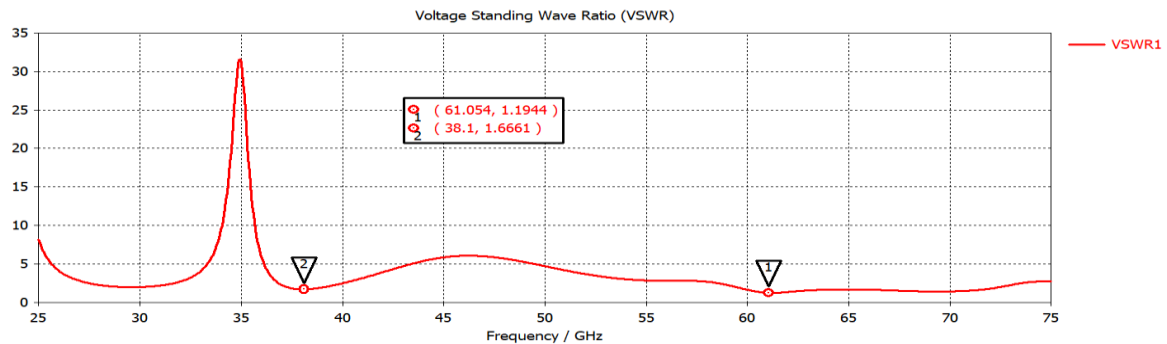

FIG-5: VSWR FOR THE ANTENNA

(C): FARFIELD DIRECTIVITY

Polar plots of far field directivity for the proposed antenna have been shown in fig-6 and fig-7 respectively at resonant frequency 38GHz and 61GHz. At resonant frequency 38GHz, main lobe magnitude is 7.77dB and an angular width is found to be 63.4 degree. Whereas at resonant frequency of 61GHz, main lobe magnitude is 8.94 dB and an angular width is found to be 48.0 degree. Magnitudes of directivity are found to be 7.893 dBi at resonant frequency 38GHz and 8.996 dBi at resonant frequency 61GHz. as shown in fig-8.

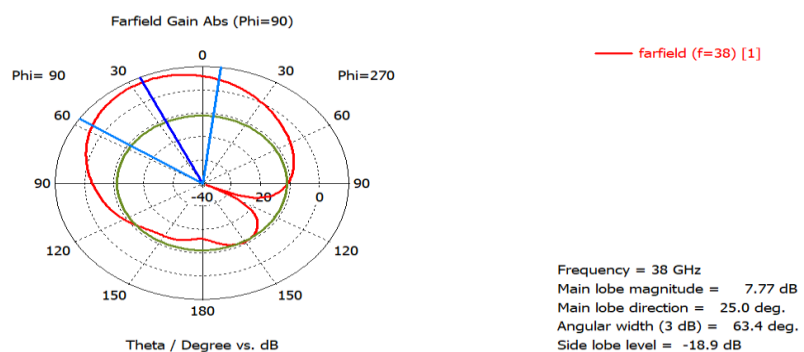

FIG-6: FAR FIELD DIRECTIVITY OF THE ANTENNA AT RESONANT FREQUENCY 38 GHZ

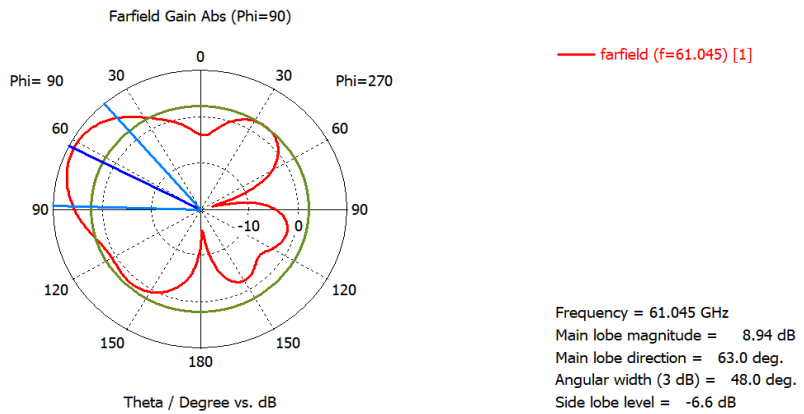

FIG-7: FAR FIELD DIRECTIVITY OF THE ANTENNA AT RESONANT FREQUENCY 61GHZ

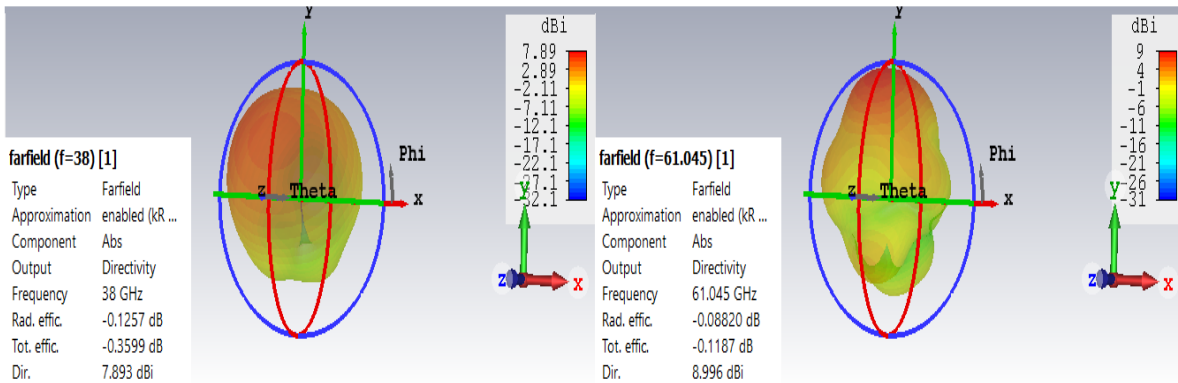

FIG-8: FAR FIELD DIRECTIVITY AT RESONANT FREQUENCIES 38GHZ, 61GHZ

(D) RADIATION PATTERN

3-D plot of radiation pattern of gain for the proposed antenna at resonant frequencies 38GHz and 61GHz have shown by fig-9 and fig-10 respectively. Gain at resonant frequency is 7.767 dB and at resonant frequency of 61.0 GHz it has been found as 8.908 dB.

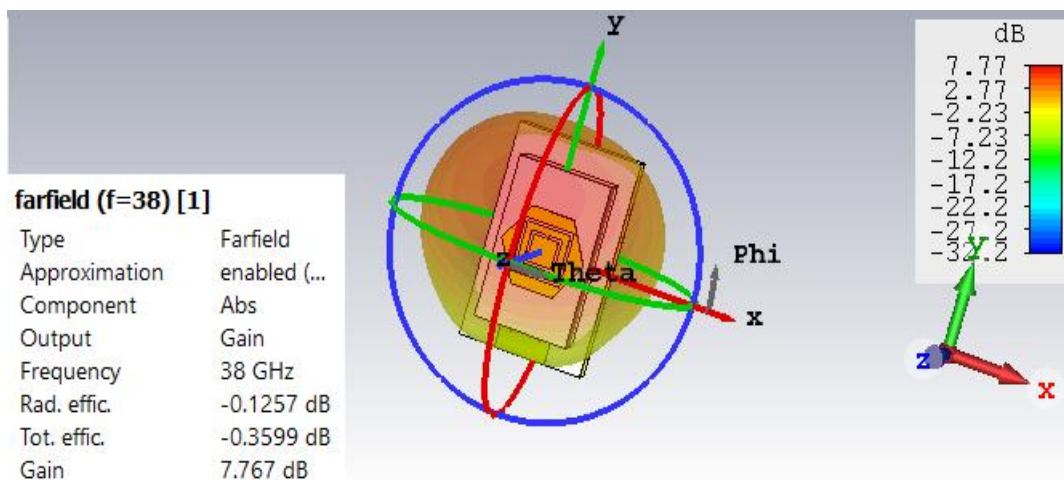

FIG-9: 3-D PLOT OF RADIATION PATTERN OF GAIN AT RESONANT FREQUENCY OF 38 GHZ FOR THE PROPOSED ANTENNA

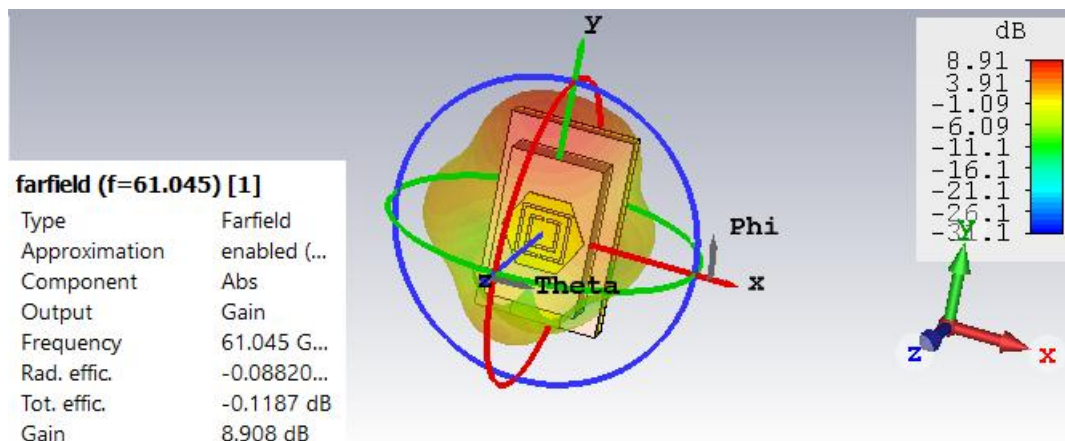

FIG-10: 3-D PLOT OF RADIATION PATTERN OF GAIN AT RESONANT FREQUENCY OF 61GHZ FOR THE PROPOSED ANTENNA.

TABLE-2 SUMMARY OF SIMULATED RESULTS

Parameter	magnitude	
	38GHz	61GHz
Resonant frequency	38GHz	61GHz
Return loss	-12.044dB	-21.411dB
Bandwidth at -10 dB	1.69 GHz	12.775 GHz
Bandwidth %	4.41 %	21 %
VSWR	1.6661	1.1994
Gain	7.767 dB	8.908 dB
Directivity	7.893dBi	8.996 dBi
Radiation efficiency	-0.1257 dB	- 0.08820 dB
Main lobe direction	25.0 deg.	63.0 deg.
Main lobe magnitude	7.77 dB	8.94 dB

From the table -2 it is well vivid that antenna has exhibited more negative value of return loss, hence proposed antenna has satisfactory return loss. Band width of the antenna is considerably very large. More the main lobe direction better is radiation pattern hence it has almost symmetrical radiation pattern.

3. CONCLUSION

This research was aimed to design a 5G/6G antenna using proximity coupled feed hexagonal patch antenna with dual split square slots. The simulated results exhibited very good agreement with the desired range of frequencies as 38 GHz and 61GHz which are suitable for 5G/6G candidate applications. The proposed antenna has higher gain, larger bandwidth, almost symmetrical radiation and satisfactory return loss at desired frequencies of 38 GHz and 61GHz. Results and analysis of the proposed antenna infers that it could be a good candidate for future 5G/6G applications.

REFERENCES

[1] Z. Yang, "Antenna in Cellular Phones for Mobile Communication," in Proceedings of the IEEE, Vol.100, No.7pp.2286-2296, July 2012.

[2] Cheng-Xiang Wang; Haider, F.; Xiqi Gao; Xiao-Hu You; Yang Yang; Dongfeng Yuan; Aggoune, H.; Fletcher, S.; Hepsaydir, E.; "cellular architecture and key technologies for 5G wireless communication networks," communications Magazine, IEEE, Vol.52no.2, pp.122,130, February 2014.

[3] T.S. Rappaport, S.Sun, R.Mayzus, H.Zhao, Y.Azr, K.Wang, J.K.Schulz, M.Samimi, and F.Guterrez, "Millimeter Wave Mobile Communications for 5G cellular: it will work!," IEEE Access, vol.1, pp.335-349, 2013.

[4] N.Ojaruodiparchin, M.Shen, S.Zhang, and G.F.Pederson, "A swtchable 3D-coverage phased array antenna package for 5G mobile terminals," IEEE Antenna and Wireless Propagation Letters, vol.15, pp.1747-1750, 2016.

[5]A.I.Sulyman, A.T.Nassar, M.K.Samimi, F.R.Mac-Cartney, T.S.Pappaport, and A.Alsanie," Radio propagation path loss models for 5Gcellular networks in the 28 GHz and 38 GHzmillimeter-wave bands,"IEEEcommunications Magazine, vol.52, no.21, pp.78-86, 20143.

[6] Dr. Sandhya Rajashekhar, impact of advertising on brand preference of high involvement products. ISSN-2319-2828, vol-2, no.4, pg. no.202-211

[7]www.wikipedia.com: 5G,Ka-band

BIOGRAPHIES

Mr. Mahesh Narayan born on 2nd July of 1963. He obtained his Master's Degree in Physics (solid state physics) from Banaras Hindu University (BHU), Varanasi, U.P, in India. He is also graduate in PMS group with B.SC (HONS) Physics. He has more than 29 years of experience in teaching, different branches of applied science and especially in physics. Presently he is working as a senior Lecturer of Physics in SSV inters college, Faizabad U.P, India. He is author of several books of physics. By dint of hard work and devotion to duty, he has earned many award/honors.