

EMERGENCY MEDICAL ASSISTANCE SYSTEM USING WIRELESS NETWORK(EMAS)

V.P.Kavitha¹, A.Ashwini², S.P.Charunya³, K.Elakkia Selvi⁴, Shireen Farhana.S⁵

¹Assistant Professor, ECE, Velammal Engineering College, Chennai.

^{2,3,4,5}Student members, ECE, Velammal Engineering College, Chennai.

ABSTRACT: The aim of the program is to reduce the use of unregistered drugs and to enable people to monitor their health status through patient routes in public places such as drug stores, supermarkets, bus / train stations, highways, in areas where medical outlets are limited. Diagnosis is always a problem for people living in a rural area. At the same time, the availability of medicines also has a major impact without that big cure. And because of the costs involved in hospitals, people withholding refuse to visit a doctor and instead take drugs that are bought at a medical center. Approximately 1 in 8 (12.8%) will use non-prescription drug use in their lifetime. The purpose of this example is to provide a temporary relief that will give people a better chance of coping with health before withdrawing from the doctor. People will be able to know their current health status using this program. Based on these results the machine places the Tree on their registered mobile number. If there are any serious symptoms it would suggest that you visit your doctor for treatment. Patient health records are stored in the cloud for future treatment.

KEYWORDS: Arduino MEGA, ATMEGA 2560 Microcontroller, Temperature, Heartbeat, Wi-Fi, IOT, Rf-ID, Python, Embedded 'C, GSM.

1. INTRODUCTION

Current problems with tablet medicines include, but are not limited to: taking the wrong drug; taking the wrong dose of medicine; taking the drug at the wrong time; forget to take the medicine at all .The drugs are often taken in ways not intended by a doctor or by someone other than the person for whom they were intended. Patients often forget to take their prescribed medication or discontinue it on a doctor-recommended schedule. Existing devices for planning and sending tablet vaccines to patients do not have many important features to solve these problems. Usually we cannot understand the harm we are hurting from our body by not taking the pills at the right time, delaying the drinking or leaving it completely in the

middle, or taking the wrong mistake. A consistent lack of interaction with existing tablet devices was also noted. There is little screen teaching given to a patient using a drug. Some of the current devices have buttons that the caregiver can use to set up the phone, but there is currently no digital signal available by the caregiver. This project aims to provide an autonomous framework. A managed device that would allow the caregiver to set up a digital interface to manage the delivery of tablet medications to patients. This project aims to eliminate the use of the wrong drug type and will provide a solution to patients through an Arduino-controlled interface that will automatically diagnose vitals and determine the medical condition of the patient and determine the drug at the appropriate dose.

2. LITERATURE SURVEY

2.1. Dedicated real-time monitoring system for health care using ZigBee (29 august 2017)

AUTHOR: Omar S. Alwan, K. Prahald Rao

The paper talks about a ZigBee-based wireless application. The system has the ability to transfer data between two systems that are based on long-distance transceivers. Here, wireless transmission is used in two phases. The first part containing the Arduino with ZigBee will send signals to the second device, containing Raspberry and ZigBee. The second device will measure patient data and send it to the first device with a ZigBee transceiver. A formal program is presented by volunteers to measure body temperature which is very important to monitor and detect flu in patients.

2.2. Health monitoring system using IoT (4th April 2018)

AUTHORS:ShivleelaPatil, Dr. Sanjay Pardeshi

The paper incorporates the development of a system that provides body temperature and heart rate using the LM35 and draws the sensor respectively. These sensors connect to the Arduino control board. Arduino Wireless Data

Transmission through Wi-Fi module.ESP8266 is used for wireless data transfer to the IoT platform i.e. thing speak. Data visualization is performed on Thing speak. For a record to be archived later .This is stored on a web server to see who's logged in.

2.3. An IoT based Patient Health Monitoring System

AUTHORS: D.Shiva Rama Krishnan, Subhash Chand Gupta, Tanupriya Choudhury. (IEEE 2018)

The system used here is to monitor elderly patients and to inform doctors and loved ones. The idea of the system, that reduces the risk of sudden death by using patients who use patients by using sensor technology and using the Internet to communicate with loved ones when there are problems. The system uses a temperature sensor and a heartbeat to track the health of patients. Both sensors are connected to the Arduino-uno. Following the micro-controller life cycle is affected by the display of LcD and Wi-Fi to send data to the web-server server (wireless sensode node). In the event of any sudden change in the patient's heart or body awareness is sent about the patient using IoT. The system also displays patient temperatures and heart rate followed by live data with time signals over the Internet. So IoT-based patient monitoring system uses the Internet to effectively monitor patients' health and help the user to watch their loved ones Drom work and save lives.

2.4. A framework for low cost automatic pill dispensing unit for medication management (May ,2017)

AUTHORS: Gift Arnold Mugisha, Faith-Michael Uzoka, ChineyereNwafor-Okoli

A number of health problems stem from non-adherence to treatment, which is most common in low-income, uneducated families. Many of these families cannot afford the adhesive resources available in medicine. This paper reports in the first phase of a program aimed at developing low-cost, portable and easy-to-use pills that address the infrastructure and economic challenges of low-income families, especially in developing countries. We present the first improper implementation of our design, as well as the proposal.

2.5. A Method for Automatic Medical Diagnosis

AUTHORS: IgorGrabec, Eva Švegl, MihaelSok (March 2019)

This research paper presents a new approach to the automatic diagnosis of diseases using a personal computer.

It forms the basis of the appearance of disease, using a set of different symptoms, and a particular disease shows the set of weights given to those symptoms. Information about the patient's condition is provided by the graphic interface through which the user verifies the symptoms. The agreement between these symptoms and the distinguishing symptoms of a particular disease is estimated by the sum of the corresponding doses, where the disease associated with the general agreement is proposed as a result of the diagnosis. Disease comparison rate is calculated and expressed to evaluate the reliability of the disease. As far as automated diagnostic tests are included the algorithm is compatible with computer program properties. Finally, the effectiveness of this medical diagnostic approach is demonstrated by four general examples involving differentially expressed symptoms. The diagnostic system is similar to a sensory-neural network that runs on a peripheral basis.

3. EXISTING SYSTEM

The existing system does not involve in any sort of analysis of the event.

- The existing systems were aimed at only dispensing the medications and not on prescribing them.
- The existing systems are of two separate modules with basic functionalities such as :

1) Pill dispensing machine that automatically dispenses pill that have been preprogrammed for a particular patient.

2) A health monitoring module , that collects basic vital data's of a patient

3.1DRAWBACKS

i. Pharmaceutical queries: Many questions to the pharmacist about the effectiveness of the tablets that had to be removed from their air intake to be put into the pill. Some pharmacists believe that the pill was not good when the drug became more effective due to exposure to air, while others believe that it is better to take the tablet in reduced doses than not at all.

ii. Not patient prescribed: Existing programs were designed solely for the allocation of treatment to a specific patient. The drug with the prescribed dose was programmed into the system and the system disseminated

the drug permanently until it was disturbed externally. Existing programs were intended to deliver only medicines and not prescribe them.

iii. Human vitals monitoring: Existing purification system could not collect patients, analyze themselves and evaluate patients' medical conditions. Existing programs can only deliver medications prescribed by the medical examiner.

4. PROPOSED SYSTEM

Our proposed program aims to reduce the reduction of unregistered medications and Intern helps avoid complications in the long term. EMAS (Emergency Assistance Program) uses two modules - 1. Medication discovery and medication 2. Writing Medicines via GSM (message). This kiosk will be located in densely populated areas such as supermarkets, medical stores, and public buildings that provide easy access to people. Initially when a sick patient approaches the kiosk with the patient's EM - 18 RFID, the patient's details are recorded on the screen. EMAS uses the microcontroller Arduino MEGA 2560 and the DS18B20 digital thermometer sensors to monitor the patient's body temperature, MAX30100, sensor heart monitor and heart rate monitor that will determine the heart rate and heart rate oxygen oxygen and LCD display to show power.

The program was developed using PYTHON to analyze the values collected by different sensors and determine the status and determine the medications. The entire system is powered by +5 V power supply. The prescriptions will now be sent to mobile phones using GSM and the Wi-Fi module ESP8266. The prescriptions will be sent as text message to the telephone number registered with the patient's RFID .When the patient is diagnosed with a serious, then the program is designed to raise awareness of the patient as "serious" and will not prescribe any medication.

5. WORKING PRINCIPLE

This system is powered by +5 V power and the whole process is controlled using an Arduino MEGA 2650 controller that will process information received by various sensors. The various nerve blocks are the DS18B20, a digital thermometer that will monitor the patient's body temperature, the MAX30100, a heartbeat and a heart monitor that will determine the patient's heart rate and oxygen saturation .The recorded instruments are displayed using the LCD Display. The patient is presented

with a unique EM 18-specific RFID tag that is patient-friendly and will provide access to various kiosks. The prescriptions will be based on recorded vitals and will be sent as a text message to the patient using the Wi-Fi module ESP8266. The text message will be sent to the mobile numbers registered in the patient's RFID.

5.1. HARDWARE COMPONENTS

1. Microcontroller (Arduino MEGA 2650)



2. Programmable Resolution 1-Wire Digital Thermometer (DS18B20):



3. EM-18 RFID Reader:

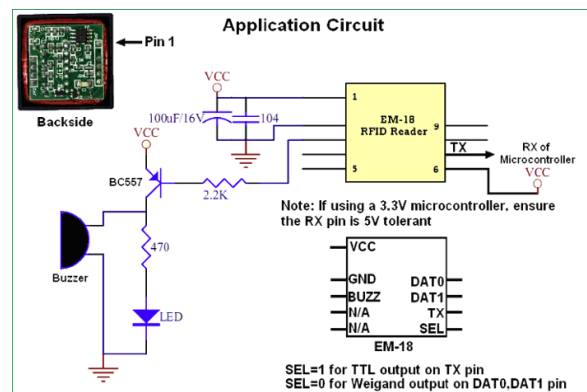

4. PulseOximetry and Heart-Rate Sensor IC for Wearable Health (MAX30100):

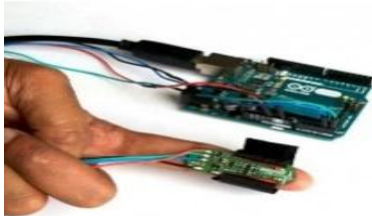

system immediately suggests the patient to consult a physician immediately

5. LCD DISPLAY

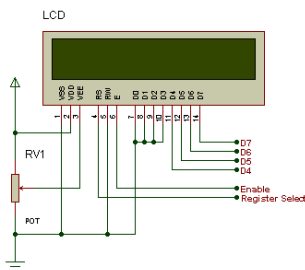

8. RESULT:

S.no	Questions	Patient-1	Patient-2
1	Do u have headache?	Severe	Mild
2	Do u have fever?	Severe	No
3	Do u have stomach pain?	Mild	Mild
4	Do u have body pain?	Severe	No
5	Do u have vomiting sensation?	No	Severe
Result	-	Consult a doctor	Take Acetaminophen for 3 days (after food)

6. SOFTWARE USED:

1. PYTHON
2. EMBEDDED-C

REFERENCES

7. CONCLUSION:

The continuous technological progresses in the healthcare industry, has transformed significantly in the past few years. Evaluating, diagnosing and treating patients from a distance is nowadays possible due to telemedicine. Electronic medical records allow physicians to access records online and store them securely in order to give their patients access to their personal health records as well. EMAS aims at providing a more accessible and easy way of health monitoring. EMAS provides the automatic diagnosis of diseases using a microcontroller. The patients symptoms and vitals are recorded by the various sensors .These sensors convert physical data to electrical signal which are processed by the microcontroller. The EMAS also asks questions based on the symptoms and recordings of the sensors and diagnoses the condition of the patient. Based on the disease the system sends the medicines to be consumed to the registered mobile number. In-case of critical condition or uncertainty of the symptoms, the

1. S. Mukund and N.K.Srinath (2016) "Design of Automatic Medication Dispenser",International Journal of Advanced Research in Computer and Communication Engineering,Vol. 5, Issue 7, July 2016
2. Suraj Shinde, NitinBange, Monika Kumbhar, SnehalPatil(2017) "Smart Medication Dispenser", International Journal of Advanced Research in Electronics and Communication Engineering (IJARECE), Volume 6, Issue 4, April 2017
3. Mrityunjaya D H, Kartik J Uttarkar, Teja B, KotreshHiremath," Automatic Pill Dispenser "(2016), International Journal of Advanced Research in Computer and Communication Engineering,Vol. 5, Issue 7, July 2016
4. Ravi Aavula, M.Kruthini, N.Raviteja, K.Shashank," Smart Health Consulting Android System" (2017),International Journal of Innovative Research in Science, Engineering and Technology , Vol. 6, Issue 3, March 2017
5. Muhammad WasimMunir, Sayed Muhammad Omair, M. Zeeshan UI Haque, An Android based Application for Determine a Specialized Hospital Nearest to Patient's



Location", International Journal of Computer Applications, May 2015.

6. S.Sundhar, Vasanth "Novel Framework for Smart Health Consulting Using Android Device", International Journal of Advance Engineering and Research Development, Volume 4, Issue 2, February 2017.