

Sinusoidal Control of PMSM Motors using DSPIC30F DSC

Archana¹, Madusudhan²

¹PG student, Department of E&EE, SIT Tumakuru-572103

²Director, ATDC Technologies, Tumakuru-572103

Abstract-Permanent magnet synchronous motors (PMSM) exhibit robustness, resulting in high efficiency. The sinusoidal nature of the PMSM motor can be perfectly analyzed by using DSPIC30F peripherals. A PMSM motor drive with built in sensors can be used for control mechanism. In this paper, a sinusoidal control methodology is used. For generating sinusoidal voltages, a Space Vector Modulation (SVM) is used. The three phase inverter is built using IGBT module consisting of six IGBT's. The whole motor control circuit is built around a DSPIC family of controllers having specialized ADC's periphery and PWM periphery which are very much essential in this project.

Keywords-FOC, SVM, DSPIC30F.PMSM.

I. INTRODUCTION

In general many types of motors can be used in various applications like domestic equipments, industrial and electrical equipments, automobiles, toys, as the motors are used for getting rotary movement. The various aspects of the motor parameters like speed, torque and load current are necessary to control when motors are being used. Motors can be used in many applications. The type of the motor selected depends on the application and desired functionalities. Motors can be classified as AC and DC motors. AC motors do not have brushes which needs constant monitoring and replacement at regular intervals which results in power wastage. The main drawback in AC motors is speed control is not easy and torque v/s voltage control is difficult while the speed is controlled. DC motors provide very good speed and torque control for industrial applications and speed control is also comparatively very easy. DC motors have brushes which is the main drawback. They have constant torque over wide range of speed. The special types of DC motors involve BLDC and PMSM. They work on DC motor but do not have brushes. They consist of specialized motor drivers. Presently in many types of equipments, AC motors are being replaced by BLDC motors for ex. Washing machines, refrigerators, air conditioners. Many electrical vehicles are available in market and this is the upcoming advancement in industries. Many electrical vehicles use PMSM motors due to its ease of speed and torque control, less power consumption and high performance. In industries AC and DC induction machines are used. In future they will be replaced by PMSM motors due to their speed torque characteristics. With the availability of powerful and dedicated DSPIC based controllers, implementation of motor control hardware and algorithms has become easier. With increase in production and demand, the cost of PMSM motor is decreasing with increase in use, which helps in easy replacement of AC and DC machines.

II. CONSTRUCTION OF PMSM

A permanent magnet synchronous motor uses permanent magnet embedded in steel rotor to create a constant magnetic field. The principle of operation of the machine depends on the interaction of rotating magnetic field of the stator and constant magnetic of the rotor. When the three phase winding of the stator is energized, a rotating magnetic field is set up. At synchronous speed, the rotor field poles lock with the rotating magnetic field to produce torque and hence the rotor continues to rotate.

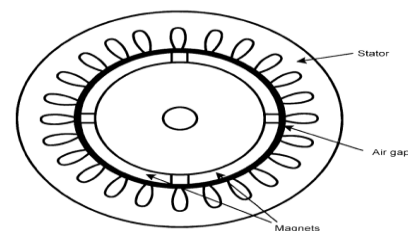

Fig.1 Cross section of PMSM

Based on the placement of the permanent magnets on the rotor they can be classified as:

- i: Surface Permanent magnet motor.
- ii: Interior permanent magnet motor.

In SPM motor, the permanent magnets are mounted on the rotor surface. This type of the motor is not robust and is not suited for high speed applications. The dynamic performance of this type of motor is superior and is used in high performance machine drives and robotics.

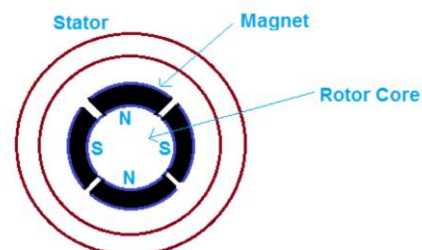

Fig.2 Surface permanent magnet motor.

In Interior permanent magnet motor, the permanent magnets are embedded in the rotor instead of mounting on the surface. This type of motor provides robustness and can be used in high speed applications.

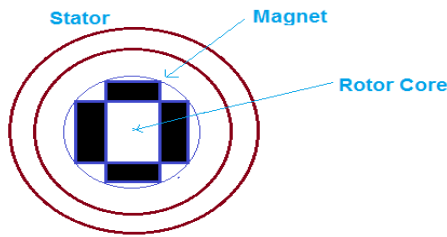

Fig.3 Interior permanent magnet motor.

III. PROPOSED BLOCK DIAGRAM

In this paper, the proposed block diagram is shown in the fig 4. The potentiometer R4 is used to detect the desired speed or the reference speed. The whole system will be built around a DSPIC family of controllers. The three phase inverter will be built using IGBT module which consists of six IGBT's. The rotor position is detected using magnetic position sensor which is used to measure rotary angle, RPM. The latest trend is to use hall effect based magnetic sensors which are similar to the optical quadrature encoder. The encoders will have three output signals A, B and Z. A and B will have similar signals but shifted by 90° and will give Pulses per Rotation (PPR). In this proposed project, we have selected a position sensor which gives 1024 (PPR) which is nothing but 10 bit output. A leads B when motor is running in clockwise direction and B leads A when the motor is running in counter clock wise direction. Z gives a small pulse indicating completion of rotation. This is also called as Index pulse. Considering outputs from Z, A and B, 60° sector change over is found out in the software. This is taken as reference while generating SVM where switching pattern of IGBT's changes when rotor moves from 160° sector (There are six sector each containing 60°). The magnetic position sensor is used to indirectly measure linear movement and also calculate the angle of movement which decides present sector.

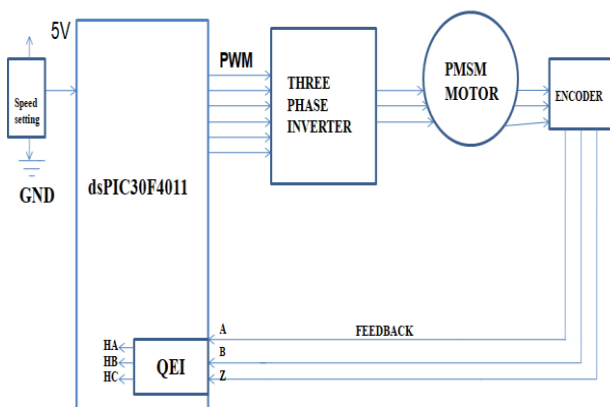

Fig.4 Block diagram

IV. CONTROL STRATEGY

A.FOC (Field Oriented Control)

The basic principle of FOC is based on applying maximum torque to the rotor. The torque will be maximum when the force applied is perpendicular to the object which is moved. The block diagram of the FOC is shown in fig 5.

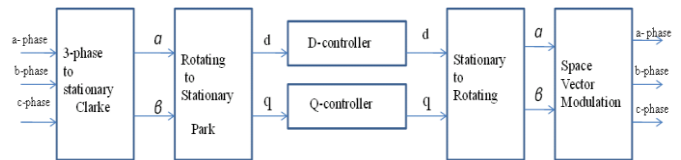

Fig 5. Basic principle of FOC

The block diagram of FOC is shown in Fig 6. The motor phase currents are measured. The three phase stator currents are transformed into stationary two phase system using Clarke's transformation. The rotor angle is calculated. The stator currents are transformed into d-q coordinate system using Park's transformation. The reference values of currents i_d ref and i_q ref controls rotor magnetizing flux. The error signals will be fed to the PI controller. V_d and V_q are voltage vectors provided by the output of the controller which in turn are given to the motor. From the encoder pulses input, a new angle is measured. The output values of V_d and V_q are fed back to stationary reference frame using the new angle. The values of V_d and V_q are used to calculate the PWM duty cycle values which will generate the voltage vector. After every discrete PWM cycle, the mechanical speed is calculated. At the end of conversion of data, the FOC software is implemented in the ADC interrupt service routine.

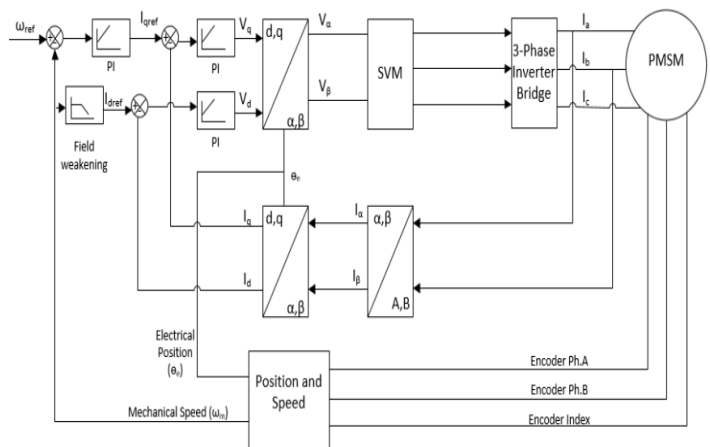

Fig 6. Block of FOC

B. SVM(Space Vector Modulation)

SVPWM technique is the next step to derive the pulse width modulation signals for the inverter switches to generate three phase motor voltages in the vector control process. The process of generating PWM signals will be reduced to few simpler equations if SVPWM is used. The

inverse Clarke's transformation is used in this implementation which is folded in the SVM routine. The three outputs of the inverter can be connected in any one of the two states. The output of the inverter can be connected either to (+) bus rail or (-) rail which provides eight possible states of the output. There will be no line to line voltages across any of the phases when all the three outputs of the inverter are connected to either (+) or (-) bus and are considered as null states. These states are plotted at the origin of the SVM star. The remaining six states are represented as vectors with 60° phase difference between adjacent states. the space vectors for three phase inverters is shown in fig 6.

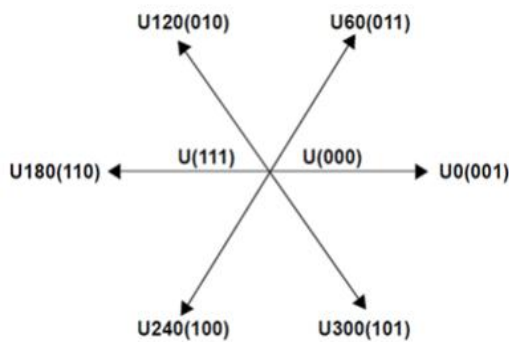

Fig.7 Space vectors for three phase inverter

The inverter states for the implemented Space Vector Modulation is shown in fig 8

C	B	A	V _{ab}	V _{bc}	V _{ca}	V _{ds}	V _{qs}	Vector
0	0	0	0	0	0	0	0	U(000)
0	0	1	V _{dc}	0	-V _{dc}	2/3V _{dc}	0	U ₀
0	1	1	0	V _{dc}	-V _{dc}	V _{dc} /3	V _{dc} /3	U ₆₀
0	1	0	-V _{dc}	V _{dc}	0	-V _{dc} /3	V _{dc} /3	U ₁₂₀
1	1	0	-V _{dc}	0	V _{dc}	-2V _{dc} /3	0	U ₁₈₀
1	0	0	0	-V _{dc}	V _{dc}	-V _{dc} /3	-V _{dc} /3	U ₂₄₀
1	0	1	V _{dc}	-V _{dc}	0	V _{dc} /3	-V _{dc} /3	U ₃₀₀
1	1	1	0	0	0	0	0	U(111)

Fig.8 SVM inverter states.

In SVPWM, the representation of any resultant vector is the sum of two adjacent vectors. U_{OUT} is the resultant desired vector which lies between U₆₀ and U₀. The output applied for time T₁ is U₀ and U₆₀ is the output applied for time T₂. The resulting voltage for time T will be U_{OUT}. The vector diagram showing average SVPWM is shown in fig 9.

The equations representing the average SVPWM are

$$T_0 = \text{Null Vector}$$

$$T = T_1 + T_2 + T_0 = \text{PWM Period}$$

$$U_{OUT} = (T_1/T) \cdot U_0 + (T_2/T) \cdot U_{60}$$

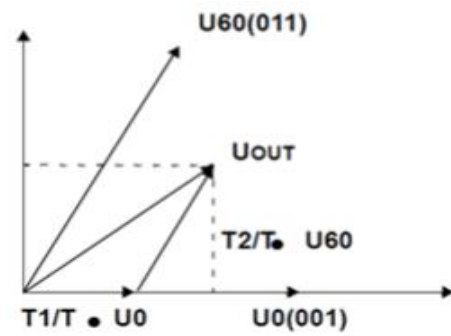
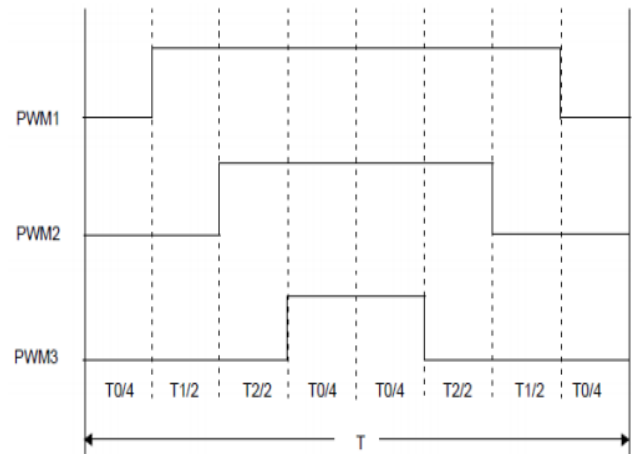

Fig.9 Average SVPWM

T₀ is a time where null vector is applied (no effective voltage is applied across its windings). By using Inverse Clarke's transformation, the values of T₁ and T₂ can be found out. A shift of 30 degrees will be observed in the SVM star as reference axis for SVM is generated by reversal of V and V as shown in fig 9. The two axes along with the voltage vector timings which binds the sector equals T₁ and T₂. In the remaining time T₀ of the switching time T, the null vectors are applied. The generation of symmetrical pulse pattern which gives minimum pulse pattern is shown in fig 10.



The rotor position must be known accurately for the FOC to work properly. The precise rotor position can be determined if the encoders have index pulse. The motor will be running in one direction if the A pulse train leads the B pulse train and the motor will be rotating in the opposite direction if B pulse train leads the A pulse train. The position measurement will be obtained precisely if there are large numbers of encoder pulses. A two pulse train in quadrature with each other will be given by the encoder as shown in fig 11 and fig 12.

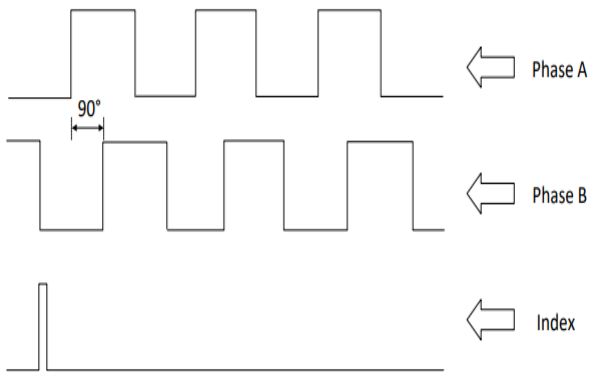

Fig.11 Encoder phase signals and index pulse for certain direction of rotation

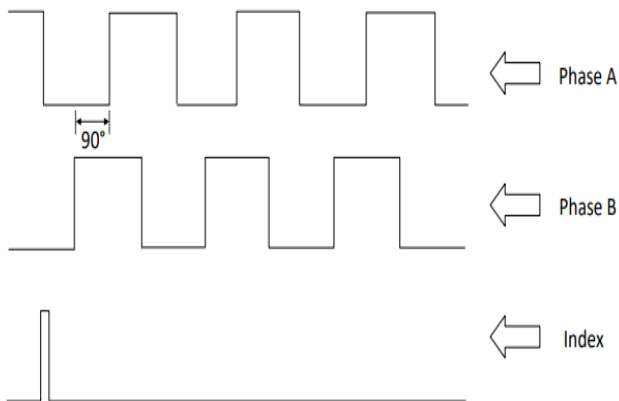

Fig.12 Encoder phase signals and index pulse for opposite direction of rotation

V. IMPLEMENTATION

A. PCB Schematic

The output to the IC drivers. The IC driver used here for the implementation is IR2101. The input of the driver is used to drive the gate of the MOSFET's or the IGBT's . the output of the source is used inturn to drive the motors. The capacitors are used which acts as a storage device. In case of any drop in the voltage across the circuit, the capacitor is used to boost up or provide the necessary voltage across the machine.(i.e 5v). A electrolytic capacitor is also used which can be served as a battery. The PWM switching signals are used to drive the motor terminals (U,V,W).

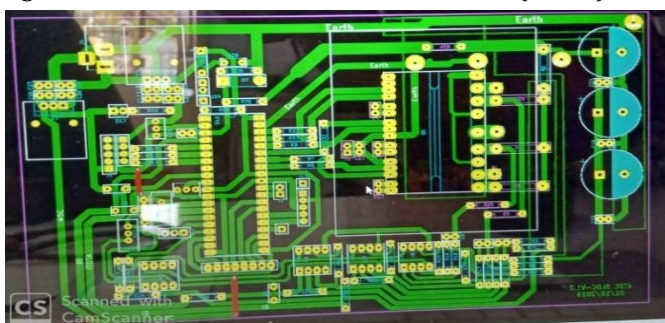

Fig 13.a PCB layout

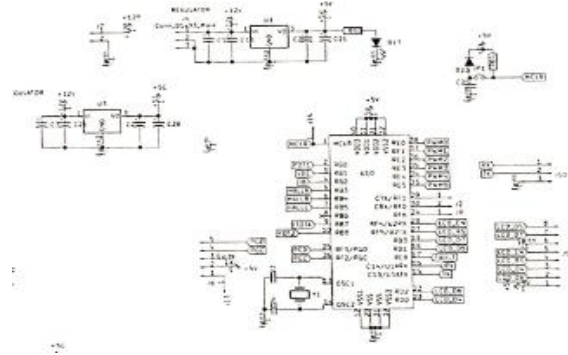

Fig13.b.power supply and DSPIC controller

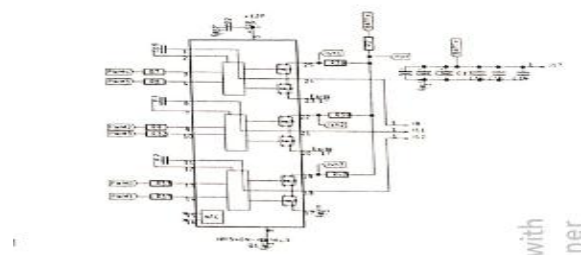

Fig.13.c IGBT module

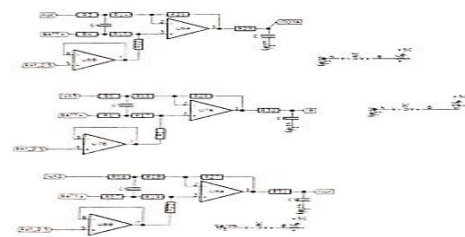

Fig 13.d Feedback circuit

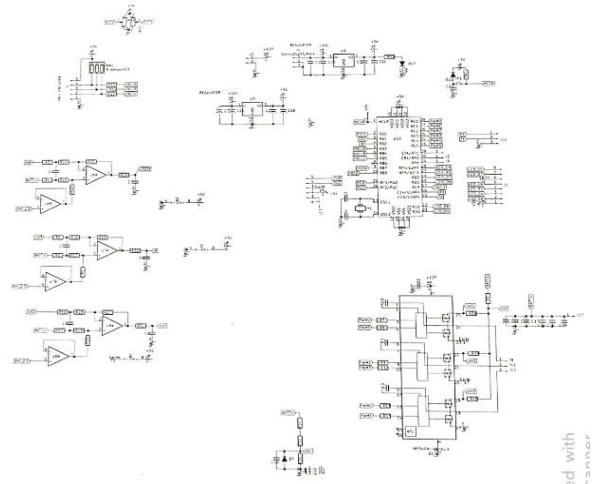

Fig 13.e Overall Schematic



Fig 13.f Motor used



Fig 13.g Hardware used

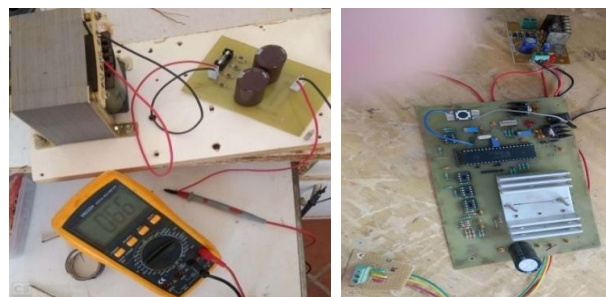

Fig 13.h Testing conditions

B. CRO waveforms

The CRO results are obtained by testing the hardware arrangement. The two phases output are obtained. The controller is used along with the filter to obtain these two phase outputs. The outputs for RY, YB and BR phases are shown in the below figure 4.8. The following figures show that the voltages which are line voltages are generated by the sine PWM and SVM. In order to get clarity only two phase voltages are generated. The SVM generated phase voltages have third harmonic component imposed on the fundamental component. The SVM generated phase voltages for Phase RY, Phase YB and Phase YB are shown in the figures 14.a, 14.b and 14.c respectively. Having the phase shift of 120° between them, the third harmonic component in line voltages are cancelled out in a way that it gets boosted to 100%. The SVM generated voltages are with higher amplitude nearly about 15% compared to sine PWM. The sine waves are obtained by the sine PWM generated phase voltages shown in figures 14.d and 14.e accordingly.



Fig 14.a RY phase

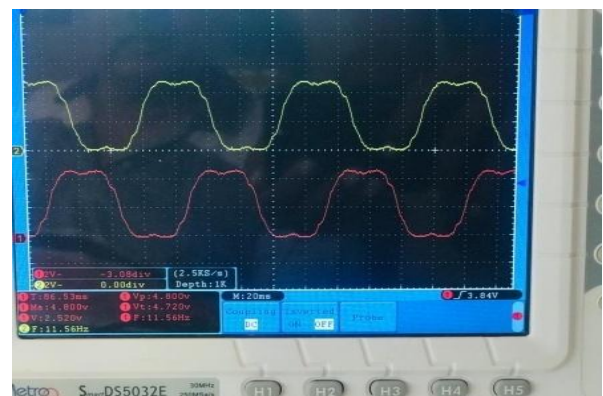

Fig 14.b YB phase

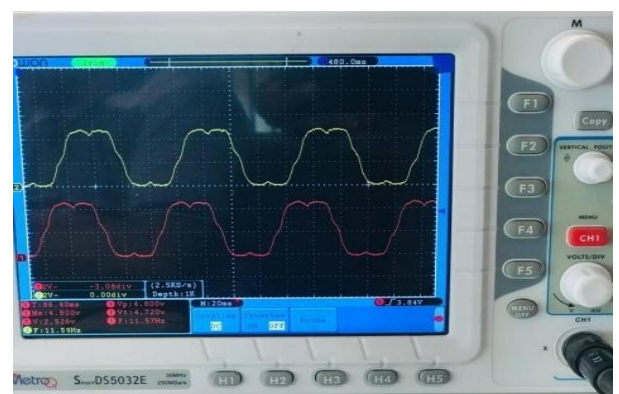

Fig 14.c BR phase

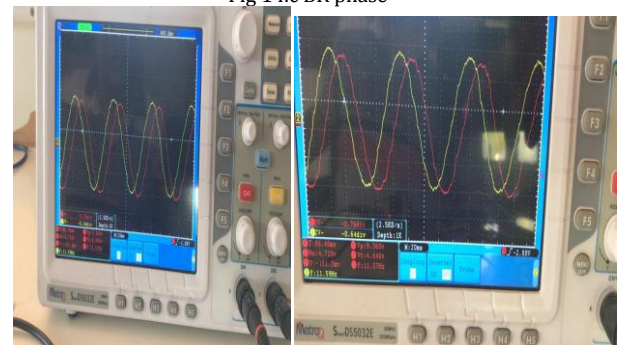

Fig 14.d SVM generated voltages

VI. CONCLUSION

The DSPIC30F4011 substitutes an ideal and low cost solution for the control PMSM Motor control with sinusoidal voltages with the help of various motor control peripherals such as PWM and ADC peripherals which are very important in this project for the implementation of motor control along with Space Vector Modulation (SVM) for sine wave generation along with the PI controller which makes the motor control easy. This application can be used in the control mechanism of lift doors.

REFERENCES

- [1] S. Sakunthala, R. Kiranmayi and P. N. Mandadi, "A study on industrial motor drives: Comparison and applications of PMSM and BLDC motor drives," 2017 International Conference on Energy, Communication, Data Analytics and Soft Computing (ICECDS), Chennai, 2017, 537-540.
- [2] C. Sain, P. K. Biswas and A. Banerjee, "Design and analysis of open loop model of a Permanent Magnet Synchronous Motor (PMSM) drive," 2015 International Conference on Energy, Power and Environment: Towards Sustainable Growth (ICEPE), Shillong, 2015, pp. 1-6.
- [3] M. Vipin and S. George, "Hardware implementation of space vector PWM control of Permanent Magnet Synchronous Motor," 2014 Annual International Conference on Emerging Research Areas: Magnetism, Machines and Drives (AICERA/iCMMD), Kottayam, 2014, pp. 1-5.
- [4] Modern Power Electronics and AC Drives by BIMAL K. BOSE.
- [5] Microchip Application Notes AN885, AN957