

Resilient Modulus Characteristics of Soil Stabilized Materials for Subgrade and Subbase Soil

Niyati Naik¹, Mahabir Panda²

¹M.TECH Scholar, Department of Civil Department, NIT Rourkela, Odisha, India

²Professor, Department of Civil Engineering, NIT Rourkela, Odisha,

Abstract-Concerned about the increasing cost in the extraction of good quality highway materials, the industrial waste can be used as an alternative materials for highway construction will partly reduce the pollution as well as the disposal problems. Mixing cementitious binder with subgrade soil increases its strength and durability during new construction or reconstruction. Resilient or stiffness are the properties of pavement layers that define their efficiency to distribute load-induced stresses within the pavement system. The resilient modulus of pavement subgrade is an essential parameter for mechanistically based pavement design procedures. The thickness of other pavement layers can be reduced if stabilization is done in the subgrade layer. In design of pavements a major concern is to determine subgrade soil in terms of Resilient Modulus (M_r). This study presents experimental results on the use of ordinary Portland cement (OPC 53) in the modification and stabilization of soils. The samples were prepared by mixing 30% of fly ash and cement with increasing percentage as 2%, 6%, and 8%, by dry weight of the soils and at varying water contents. The specimens were compacted at optimum moisture content with different percentages of stabilizers. The values of Resilient Modulus (M_r) was found by using the LTPP program protocol. The samples, after curing for 7 days and 28 days, were subjected to a laboratory repeated axial cyclic stress of fixed magnitude. The laboratory testing program produce a high quality and consistent test results database.

Key Words: Subgrade soil, Subbase soil, Moisture content, LTPP, resilient modulus.

1. INTRODUCTION

The structure of a road consist of: the formation or subgrade and the pavement. The structural element of the pavement is the foundation (soling or bottoming) also called sub-base, and the base. The base may be surfaced either with a concrete or a bituminous surfacing.

1.1 The subgrade or the formation

It is the soil foundation i.e. the surface of the natural ground (in its final shape after completion of earthwork) on which

the entire road surface rests. The importance of the subgrade lies in the fact that if it fails the performance of the whole road will be affected. A sub-grade must be able to resist the effects of both traffic and weather

1.2 Granular sub-base

The work consist of laying and compacting granular material such as natural sands, moorum, gravel, laterite, kankar on other naturally occurring or artificial soft aggregates, on prepared subgrade. The thickness of loose layers shall be so regulated that the thickness of the layer after consolidation does not exceed 150mm.

1.3 Stabilized soil subbase

The work consists of laying and compacting a subbase course of mechanically stabilized soil or soil stabilized with lime or cement on prepared subgrade. Blending materials for mechanical stabilization may be gravel, crushed stone, crushed slag, soft aggregates like laterite and kankar, natural sand or clay depending upon the grading requirements. The thickness of any layer to be stabilized shall be not less than 100mm with maximum up to 200mm, when compacted. Care shall be taken to see that the compaction of cement stabilized material is completed within two hours of its mixing.

1.4 Fly ash

India being a developing country still suffers a major problem for electricity which probably is considered as a major source for development of a country. In India mostly the power is generated by the coal based thermal power plants which in turn produce a bulk quantity of fly ash. In India the generation of fly ash has subsequently increased from 68.88 million tons in 1996-97 to 163.56 million tons in 2012-13. Out of these 163.56 million tones 100.37 million tons was utilized in India. There is a tremendous increase in the utilization from 9.63% in the year 1966-67 to 61.37% in

2012-2013. It is a fine waste material as a by-product from the power plant industries. Disposal of fly ash is certainly a big problem and requires millions of acre of land for its dumping. This is a big threat to the environment. The construction activities is increasing day by day so as the

demand for cement is also increasing. Fly ash from different sources have different properties and it's very much necessary to understand the properties that affects the performance of the pavement.

1.5 Ordinary Portland cement

This is the most common type of cement used around the world. The name is derived from Portland stone which was then quarried on the Isle of Portland in Dorset, England. The name was given by Joseph Aspdin who obtained a patent for it in 1824. William Aspdin, son of Joseph Aspdin, is regarded as the inventor of "modern" Portland cement due to his development in the 1840's. OPC is produced by heating clay minerals and limestone in a kiln to form clinker and then grinding the clinker and adding 2 to 3 percent of gypsum. There are various types of Portland cement available but the most common one is the Ordinary Portland Cement (OPC) which is grey in color. White Portland cement is also available. Portland cement being caustic in nature can cause chemical burns and with long exposure to the powder can cause lung cancer. It also releases greenhouse gases like carbon dioxide, SO₂, particulates, etc. OPC is graded according to their strength. The grade is according to the compression strength of the concrete that it attains after 28 days of setting.

1.6 Resilient Modulus (Mr)

Resilient Modulus (Mr) is a fundamental material property used to characterize Unbound Pavement materials. The resilient modulus test for soils was originally developed by Seed et. al. and was initially formulated for highway applications. Later, the test was applied to earthquake research. It is a measure of material stiffness and provides a mean to analyze stiffness of materials under different conditions, such as moisture, density and stress level. Mr is typically determined through laboratory tests by measuring stiffness of a cylindrical specimen subjected to a cyclic axial load. In a triaxial resilient modulus test a repeated axial cyclic stress of fixed magnitude, load duration and cyclic duration is applied to a cylindrical test specimen. While the specimen is subjected to this dynamic cyclic stress, it is also subjected to a static confining stress provided by a triaxial pressure chamber. Mr is defined as a ratio of applied axial deviator stress and axial recoverable strain. The resilient modulus is a measure of the "elastic" behavior (load-unload response) of the soil layer that may be in the nonlinear range. The resilient modulus can be used directly for the design of flexible pavements but must be converted to a modulus of subgrade reaction (k-value) for the design of rigid or composite pavements. Traditionally, this test measures the elastic properties of the unbound soils and requires specialized, and expensive, equipment. The test is also fairly difficult to perform. While the test is considered the state of the

art, it is not widely accepted for routine application by state transportation departments. It was not until 1986 that the resilient modulus was formally accepted and included in the AASHTO Guide for Design of Pavement Structures (1986). Also, most of these methods, which use California Bearing Ratio (CBR) and Soil Support Value (SSV), do not represent the conditions of a pavement subjected to repeated traffic loading. Recognizing this deficiency, the 1986 and the subsequent 1993 American Association of State Highway and Transportation Officials (AASHTO) design guides recommended the use of resilient modulus (Mr) for characterizing base and subgrade soils and for designing flexible pavements. Additionally, CBR, UCS, Modified Proctor test are performed.

2. METHODOLOGY AND EXPERIMENTAL INVESTIGATION

The entire study has been conducted on 1. Clayey soil (from Amco-Simco, Sundargarh), 2. Fly ash of Rourkela steel plant 2. Fly ash of Bhusan Sambalpur. 3. Ordinary Portland cement (53 grade). Initially experiments were conducted to determine the consistency of clayey soil such as liquid limit and plastic limit. Then heavy compaction tests were conducted to determine the optimum moisture content and corresponding maximum dry density. Then repeated load test was performed at different moisture content and maximum dry density for various subgrade and subbase samples. The samples were with clay soil, 30% fly ash and with different percentages of cement such as 2%, 6% and 8%.

2.1 EXPERIMENTAL INVESTIGATIONS

Soils are classified with different engineering properties which affect the behavior of soil under different conditions. The properties are Liquid Limit, Plastic Limit, Plasticity Index, Moisture content, Optimum moisture content, Modified Proctor test and Resilient Modulus test for subgrade and sub base soil. All these test have been done and results were obtained.

2.2 Test Procedure

2.2.1 Apparatus

1. Triaxial Pressure Chamber

The pressure chamber is used to contain the test specimen and the confining fluid during the test. A typical triaxial chamber suitable for use in resilient testing of soils is shown

in Figure 1. The deformation was measured externally with two spring loaded LVDTs. Air should be used in the triaxial chamber as the confining fluid for all LTPP testing.

2. Loading Device

The loading device should be a top loading, closed loop electrohydraulic testing machine with a function generator which is capable of applying repeated cycles of a harversian-shaped load pulse nominally 0.1 second in duration; followed by rest periods of nominally 0.9 second duration. The harversian shaped load pulse shall conform to definition (k).

2.2.2 Load and Specimen Response Measuring Equipment

1. Test chamber pressures shall be monitored with conventional pressure gauges, manometers or pressure transducers accurate to 0.7 kPa (0.1 psi).

2. Axial Deformation - Measuring equipment for all materials shall consist of 2 Linear Variable Differential Transducers (LVDT's) fixed to opposite sides of the piston rod outside the test chamber. These two transducers shall be located equidistant, and as close as possible to, the piston rod and shall bear on hard, fixed surfaces which are perpendicular to the LVDT axis. Spring-loaded LVDT's are required. A positive contact between the vertical LVDT's and the surface on which the tips of the transducers rest shall always be maintained during the test procedure. In addition, the two LVDT's shall be wired so that each transducer can be read and reviewed independently and the results averaged for calculation purposes.

3. Suitable signal excitation, conditioning, and recording equipment are required for simultaneous recording of axial load and deformations. The signal shall be clean and free of noise. The LVDT's shall be wired separately so each LVDT signal can be monitored independently.

2.2.3 Miscellaneous Apparatus

This includes calipers, micrometer gauge, steel rule, rubber membranes, porous stones, scales and data sheets.

2.2.4 PREPARATION OF TEST SPECIMENS

The 71 mm (2.8-inch) diameter undisturbed specimen from the thin-walled tube samples for cohesive subgrade soils is required. The specimen length shall be at least two times the diameter i.e. minimum length of 142 mm (5.6 inches).

3.1.9.5 TEST PROCEDURE

Resilient Modulus Test for Subgrade Soils

The procedure described is for laboratory compacted specimens of subgrade soils.

1. Assembly of Triaxial Chamber - Specimens trimmed from undisturbed samples and laboratory compacted specimens were placed in the triaxial chamber and loading apparatus in the following steps:-

[i]. A dry porous stone was placed on the top of the sample base of the triaxial chamber as shown in Figure 1. Paper filters should be placed between the porous stone and the sample.

[ii] The specimen was carefully placed on porous stone.

[iii] The dry porous stone was placed and the top platen on the specimen, the membrane was folded, and sealed on the top platen with an O-ring or some other pressure seal. Paper filters were placed between the porous stone and the sample. After the "specimen assembly" was in-place, the top platen should be checked to ensure that it is level. A "cross-check" level, or similar, may be used for this determination.

[iv] The assembly apparatus is to be slide into position under the axial loading device. Positioning of the chamber is extremely critical in eliminating all possible side forces on the piston rod. The loading device is then coupled to the triaxial chamber piston rod.

2. Resilient Modulus test conduction -

The following steps required to conduct the resilient modulus test on a subgrade specimen which has been installed in the triaxial chamber and placed under the loading frame.

[i] All drainage valves were opened leading into the specimen to atmospheric pressure.

[ii] The air pressure supply line was connected to the triaxial chamber and the specified pre-conditioning confining pressure of 41.4 KPa (6 psi) was applied to the test specimen. A contact stress of 10 percent + .7 kPa (+ .1 psi) of the maximum applied axial stress during each sequence number should be maintained.

[iii] Conditioning - A minimum of 500 repetitions of a load equivalent to a maximum axial stress of 27.6 kPa (4 psi) and corresponding cyclic stress of 24.8 kPa (3.6 psi) was applied by using a harversian shaped load pulse consisting of a 0.1 second load followed by a 0.9 second rest period. If the sample is still decreasing in height at the end of the conditioning period, stress cycling shall be continued up to 1000 repetitions prior to testing. The foregoing stress sequence constitutes

sample conditioning, that is, the elimination of the effects of the interval between compaction and loading and the elimination of initial loading versus reloading. This conditioning also aids in minimizing the effects of initially imperfect contact between the sample cap and the test specimen.

3. Testing Specimen

- [i] The confining pressure was 41.4 kPa (6 psi).
- [ii] 100 repetitions were applied. The average recovered deformations for each LVDT were recorded separately.
- [iii] The maximum axial stress was increased to 27.6 kPa (4psi) (Sequence No. 3) and repeat above step.
- iv. At the completion of the triaxial repeated load test, the confining pressure was reduced to zero and the sample was removed from the triaxial chamber.

Index property	Experimental Value
Liquid Limit	50.89%
Plastic Limit	29.79%
Plasticity Index	21.10%

3.1 Modified Proctor compaction test

The results of modified proctor compaction test values are represented in figure 2.

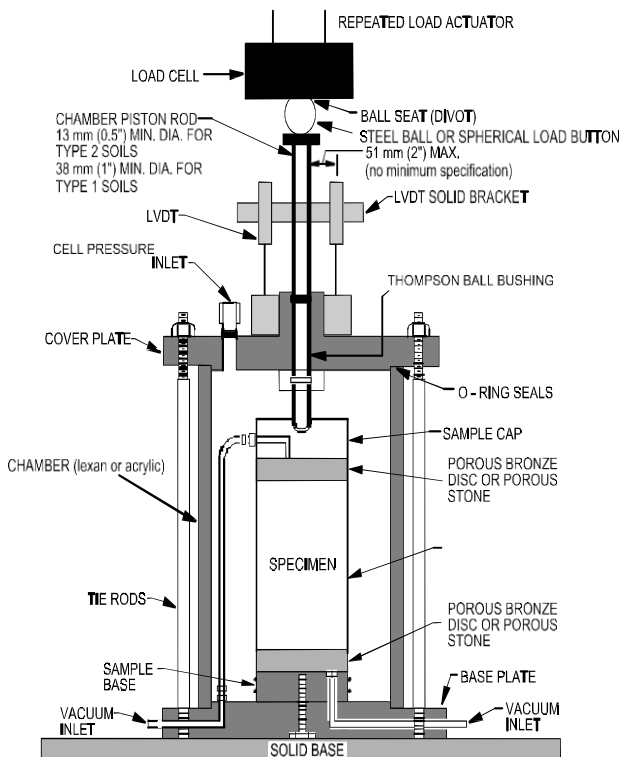

Figure 1: Typical triaxial chamber with external LVDTs and load cell.

3. RESULTS AND GRAPHS

The index properties such as liquid limit, plastic limit and Plasticity index of the clay soil are listed in the table 3 as follows:

Table 1: Index properties of clay soil

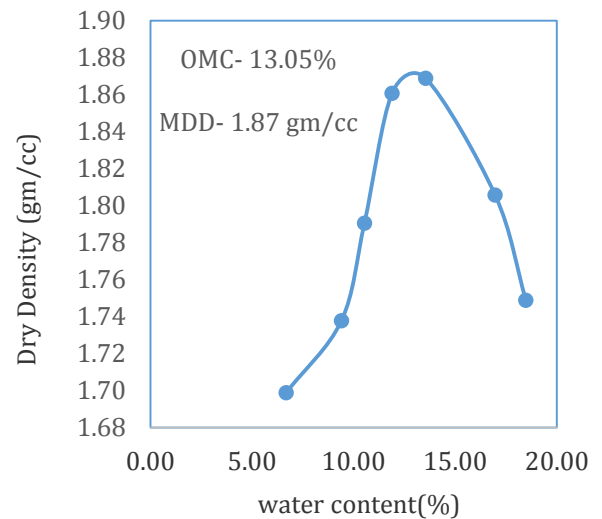

Figure 2: Modified proctor compaction for clay soil showing variation of dry density (gm/cc) with respect to water content (%).

3.2 Clay soil

(Conducted under OMC (13.05%) and MDD (1.87g/cc)).

$$K1 = 2875.95$$

$$K2 = 0.5259$$

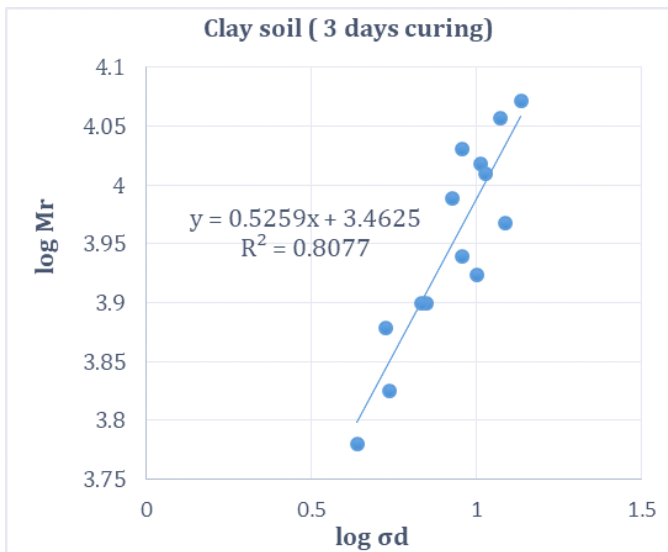

Chart -1: Sample 1 (3 days curing)

K1 = 5499.66

K2 = 0.20

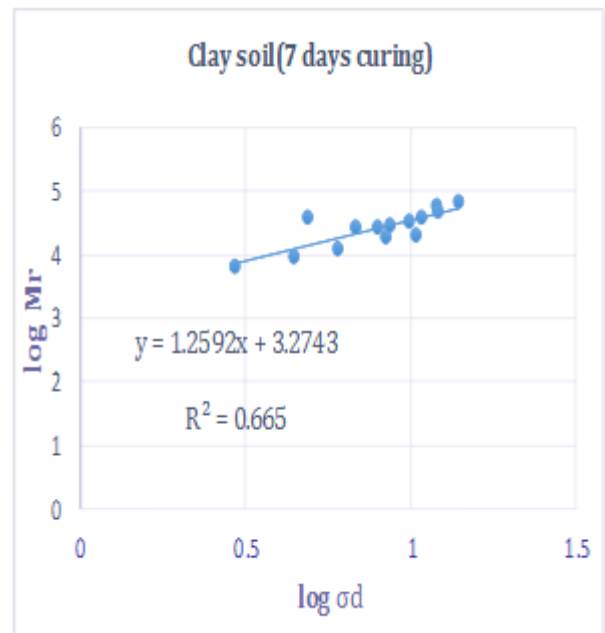

Chart -3: Sample 1 (7 days curing)

K1 = 227.50

K2 = 1.8258

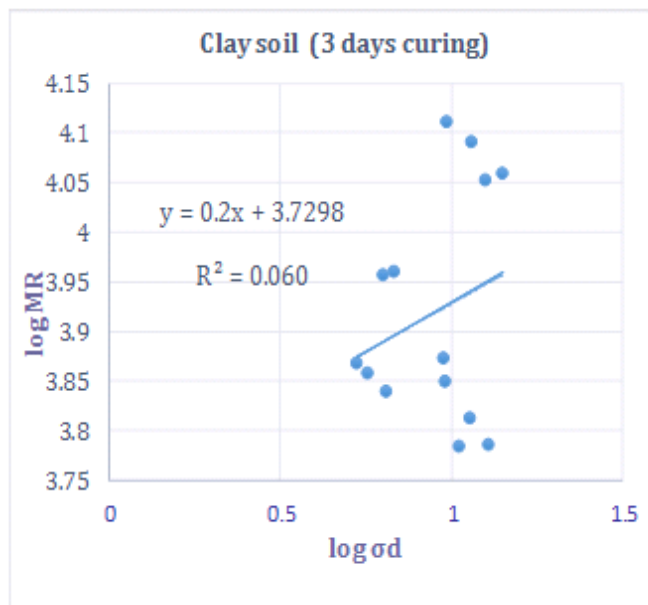

Chart -2: Sample 2 (3 days curing)

K1 = 2049.18

K2 = 1.2592

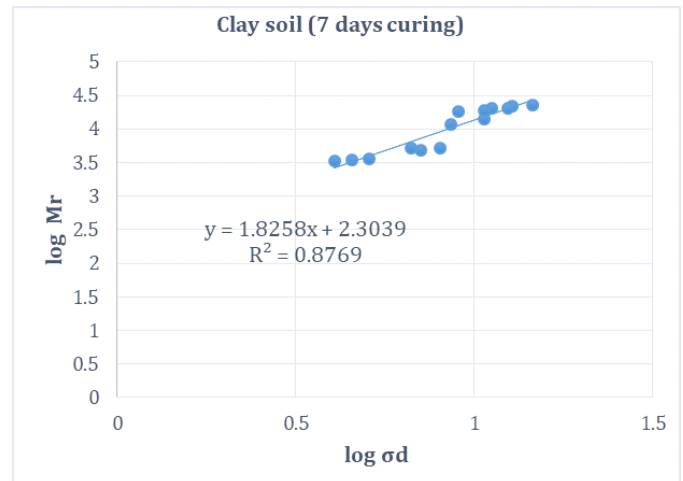

Chart -4: Sample 2 (7 days curing)

K1 = 4307.38

K2 = 0.64

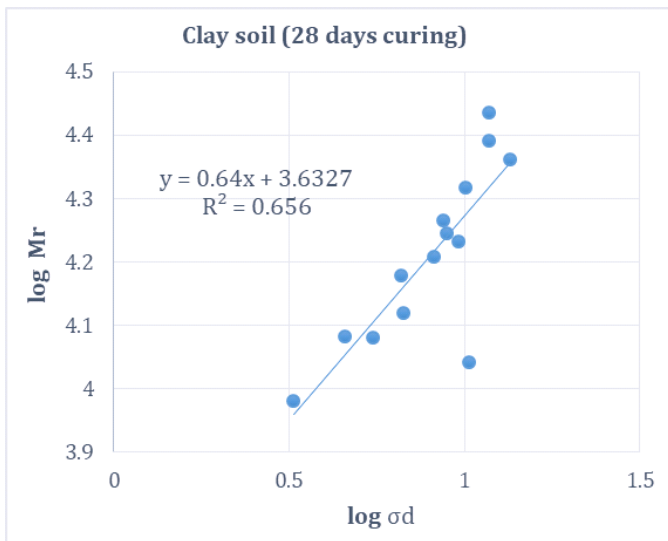

Chart -5: Sample 1 (28 days curing)

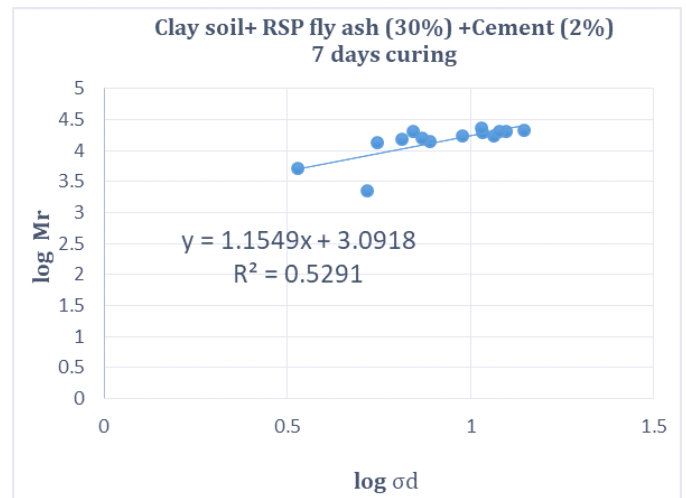

Chart -7: Sample 2- Clay soil+ RSP fly ash (30%) +Cement (2%)

k1=2727.58

k2=0.8486

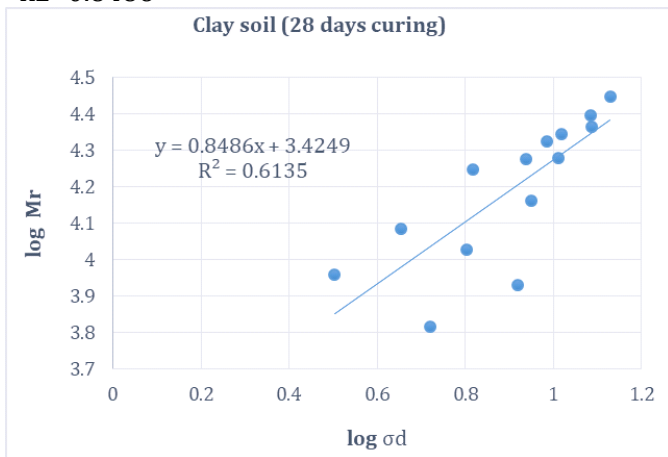

Chart -6: Sample 2 (28 days curing)

K1 = 10464.59

K2 = 0.621

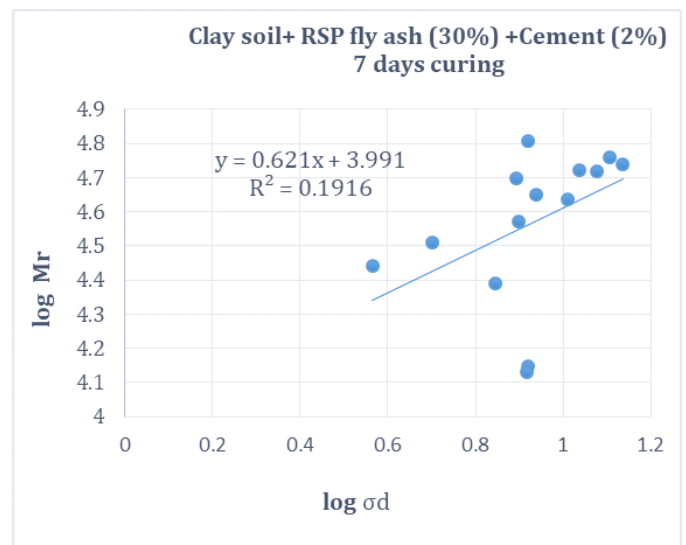

Chart -8: Sample 2- Clay soil+ RSP fly ash (30%) +Cement (2%)

K1 = 2067.74

K2 = 0.9616

3.3 FLY ASH of ROURKELA STEEL PLANT

3.4.1 for subgrade soil

This was conducted under OMC (16.70%) and MDD (1.78g/cc)

K1 = 1297.23

K2 = 1.1549

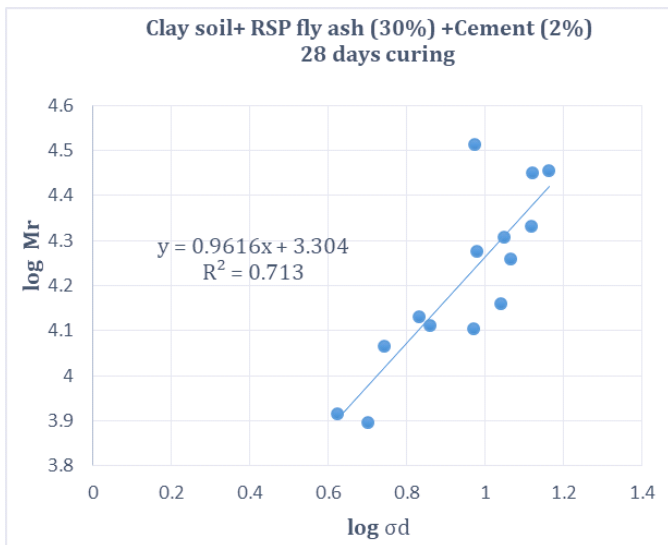

Chart -9: Sample 1- Clay soil+ RSP fly ash (30%) + Cement (2%)

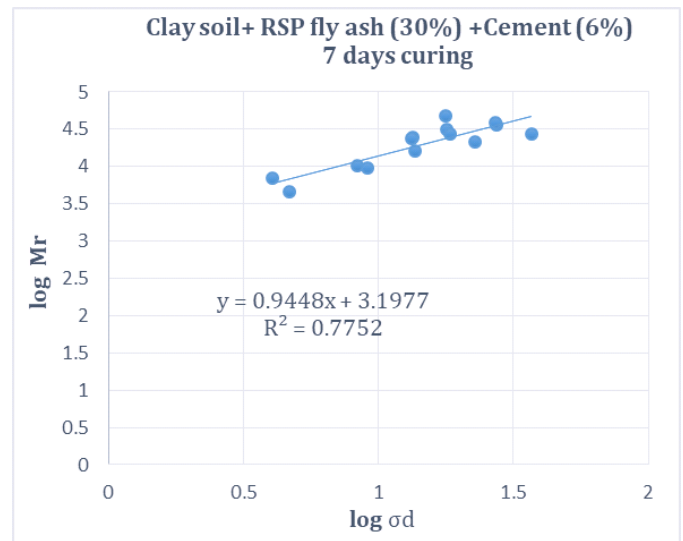

Chart -11: Sample 1- Clay soil+ RSP fly ash (30%) +Cement (2%)

K1 = 2132.02
K2 = 0.9984

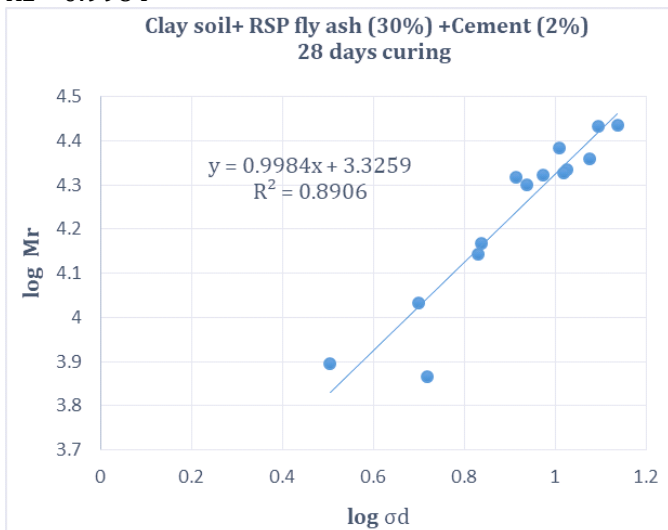

Chart -10: Sample 2- Clay soil+ RSP fly ash (30%) + Cement (2%)

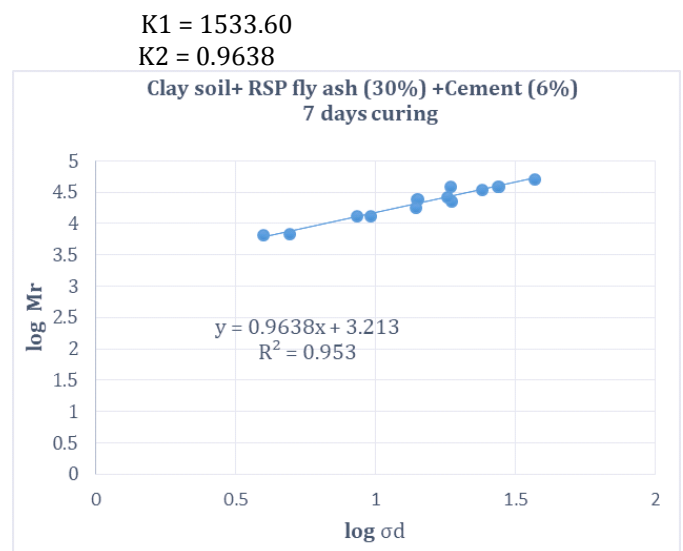

Chart -12: Sample 2- Clay soil+ RSP fly ash (30%) +Cement (2%)

3.4.2. For sub base soil

This was conducted under OMC (18.60%) and MDD (1.79g/cc).

K1 = 1618.26
K2 = 0.9448

K1 = 2598.92
K2 = 0.8752

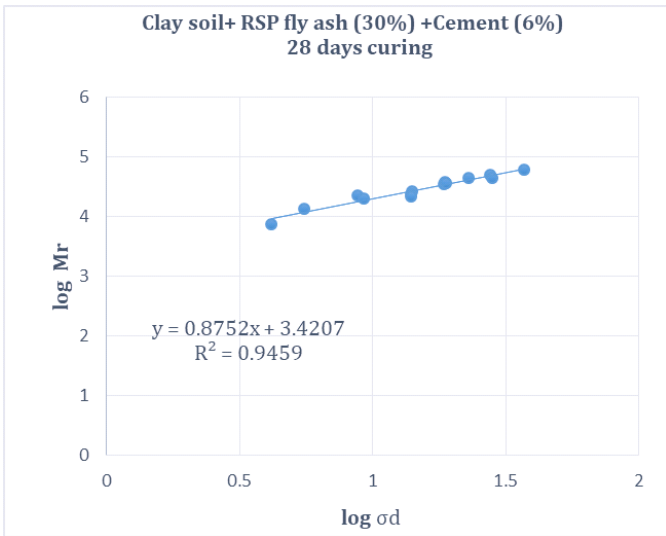

Chart -13: Sample 1- Clay soil+ RSP fly ash (30%) +Cement (2%)

K1 = 5475.58
K2 = 0.9382

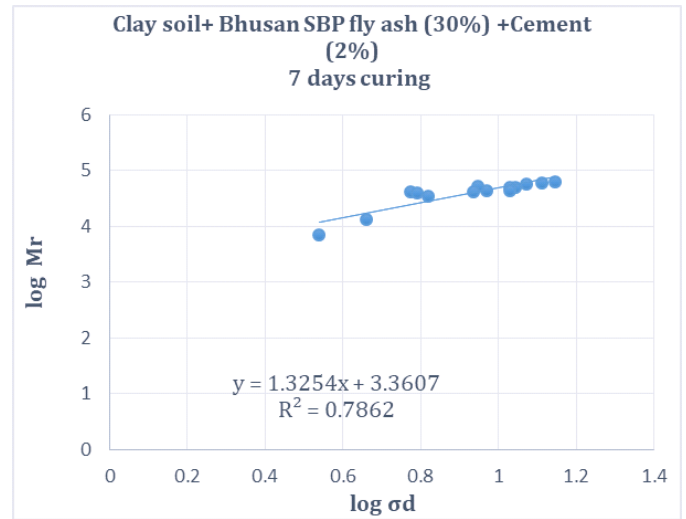

Chart -15: Sample 1 -Clay soil+ Bhusan Sambalpur fly ash (30%) +Cement (2%)

K1 = 2511.79
K2 = 0.8642

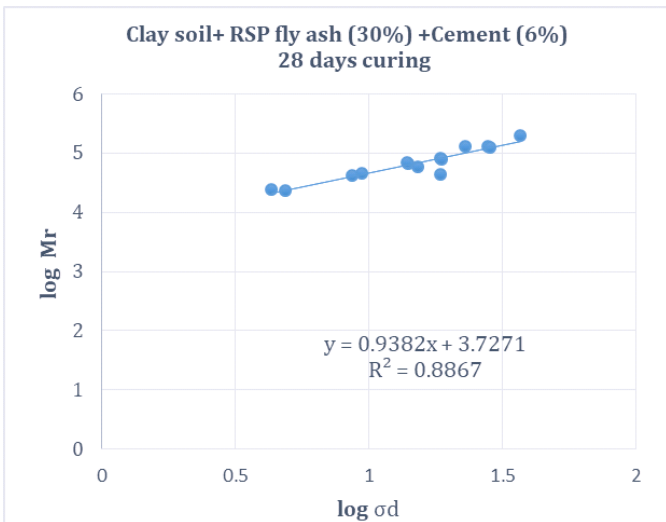

Chart -14: Sample 2- Clay soil+ RSP fly ash (30%) +Cement (2%)

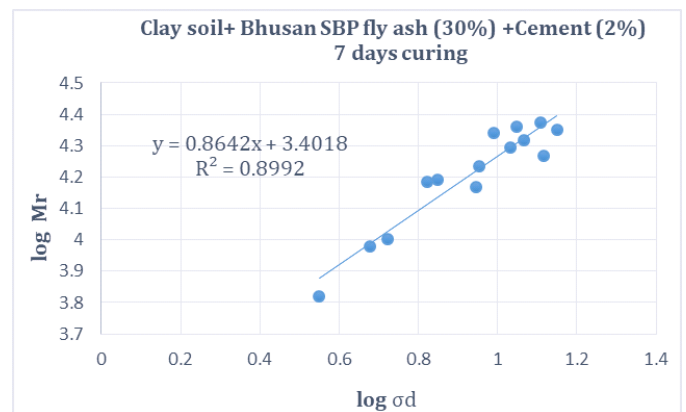

Chart -16: Sample 2 -Clay soil+ Bhusan Sambalpur fly ash (30%) +Cement (2%)

K1 =1931.62
K2 = 1.0561

3.4 FLY ASH of BHUSAN SAMBALPUR

3.5.1. For subgrade soil

This was conducted under OMC (17.26%) and MDD (1.71g/cc).

K1 = 2360.65
K2 = 1.3254

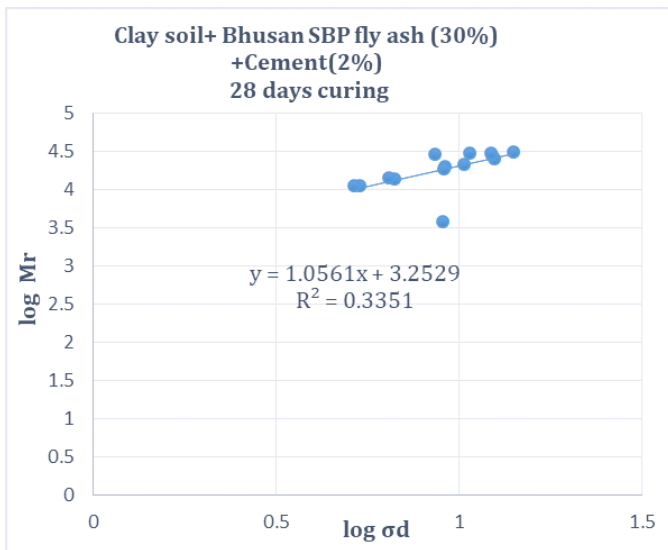

Chart-17: Sample 1 -Clay soil+ Bhusan Sambalpur fly ash (30%) +Cement (2%)

K1 = 9909.73
K2 = 0.7394

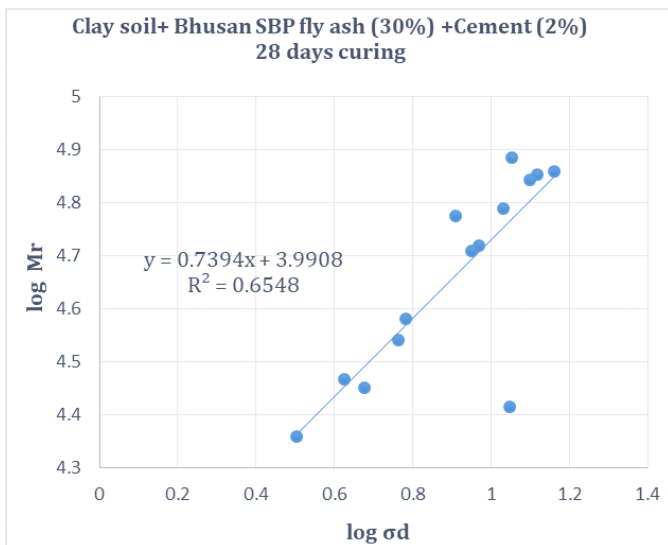

Chart-18: Sample 2 -Clay soil+ Bhusan Sambalpur fly ash (30%) +Cement (2%)

3.5.2. For sub base soil

This was conducted under OMC (19.89%) and MDD (1.73g/cc).

K1 = 3348.908
K2 = 0.7343

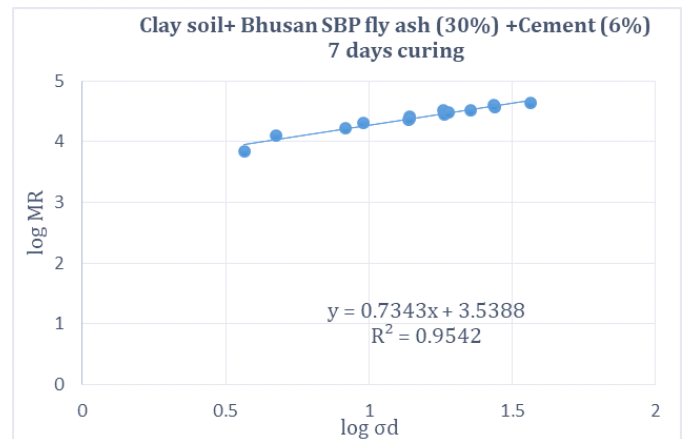

Chart-19: Sample 1 -Clay soil+ Bhusan Sambalpur fly ash (30%) +Cement (6%)

K1 = 4617.59
K2 = 0.9346

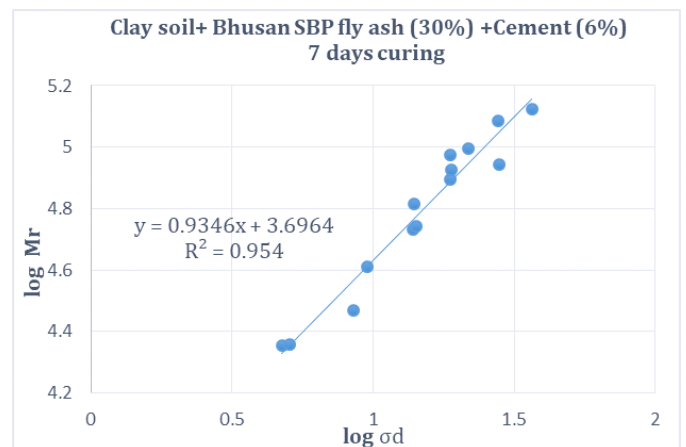

Chart-20: Sample 2 -Clay soil+ Bhusan Sambalpur fly ash (30%) +Cement (6%)

k1=3109.28
k2=0.8599

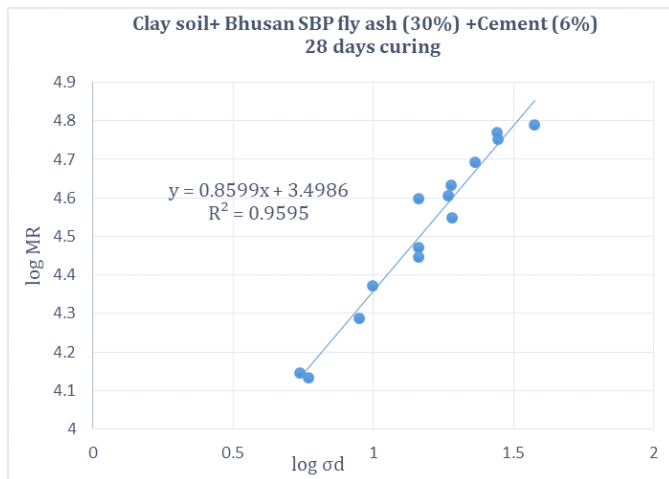

Chart-21: Sample 1 -Clay soil+ Bhusan Sambalpur fly ash (30%) +Cement (6%)

K1 = 5499.66

K2 = 0.20

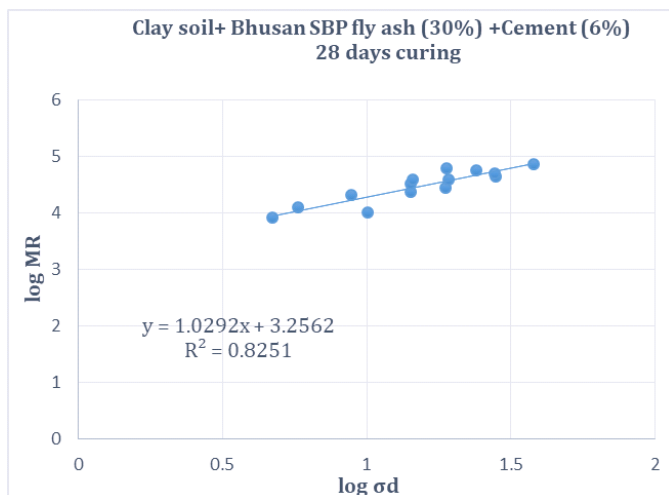

Chart-22: Sample 2 -Clay soil+ Bhusan Sambalpur fly ash (30%) +Cement (6%)

4. CONCLUSIONS

Since the modern pavement design methods require resilient properties of road pavement materials whereas there is not a simple model for estimation of resilient modulus. In this research repeated load triaxial test was conducted for various samples to find the stiffness of the soil sample. The resilient modulus of the samples are dependent on the weight of the samples as well as the moisture content of the sample. The resilient modulus increases with the increase of the unit weight of the soil. The resilient modulus values decreases with the increase of the moisture content. The less the strain indicates the higher resilient modulus value. The resilient modulus of clay soils basically does not depend on the confining pressure. The fly ash were collected from the various industries and the resilient modulus values were

found with different proportion of OPC 53 grade such as 2%,6% and 8%.The best results were found under the 8% proportion. Resilient modulus is therefore a key material characterization parameter.

ACKNOWLEDGEMENT

I would like to express my deep sense of gratitude from the core of my heart to my supervisor Prof. Mahabir Panda, HOD of Civil Engineering Department, NIT Rourkela for initiating an interesting study, his personal commitment, interesting discussion and valuable advice. He has been continuously encouraging me throughout the work and contributing with valuable guidance and supervision.

My thanks to Mr. S.C. Xess, Mr. Hari Mohan Garnayak, Mr. Rahul and Mr. Sambhu of Highway and Concrete Laboratory can never be enough in mere words. They simply helped in every possible way they could. Without their guidance and cooperation I could not have finished this research.

I also want to convey sincere thanks to my family for taking care of me. I also want to convey sincere thanks to Saroj Kumar Samal and Deepika Priyadarshini Palai who helped me to complete the work. Last but not the least I would also like to thank the Almighty whose blessings have helped me in achieving great strides.

REFERENCES

- [1]. Hani H. Titi, Mohammed B. Elias, and Sam Helwany (2006): "Determination of Typical Resilient Modulus Values for Selected Soils in Wisconsin."
- [2]. GERMAN CLAROS, W. R. HUDSON, AND KENNETH H. STOKOE II: "Modifications to Resilient Modulus Testing Procedure and Use of Synthetic "Samples for equipment calibration", TRANSPORTATION RESEARCH RECORD 1278.
- [3]. Qiang Zeng, Kefei Li, Teddy Fen- Chong, Patrick Dangla (2011): "Determination of cement hydration and Pozzolanic reaction extents for fly-ash cement pastes", Construction and Building Materials.
- [4]. Farid Sariosseiri, Balasingam Muhunthan (2008): "Effect of cement treatment on geotechnical properties of some Washington State soils", Engineering Geology.
- [5].Long-Term Pavement Performance: "Protocol P46Resilient Modulus of Unbound Granular Base/ Subbase Materials and Subgrade Soils"
- [6]. Alper Sezer, Gözde İnan, H. Recep Yılmaz, Kambiz Ramyar (2004):" Utilization of a very high lime fly ash for improvement of Izmir clay", Building and Environment.

[7]. Aykut Senol, Tuncer B. Edil, Md.Sazzad Bin- Shafique (2005): 'Soft subgrades' stabilization by using various fly ashes", Resources, Conservation and Recycling.

BIOGRAPHIES



Niyati Naik has completed her M.TECH degree from NIT Rourkela in the year 2019. Her area of interest are pavement materials, soil stabilized materials for subgrade and Subbase soil.



Prof. Mahabir Panda is working at NIT Rourkela as head of the department in the department of Civil Engineering. He completed his P.HD from IIT Kharagpur. His areas of interests are Pavement Materials, Pavement Analysis and Design.