

A Prototype Design of Psychometric Analyzer: Phase-I

Subham Chhatait¹, Ashim Nandan², Abhijit Banerjee³, Avishek Choudhury⁴

^{1,2}Department of Computer Science, New Alipore College, West Bengal, India

³State-Aided-College-Teacher, Department of Computer Science, New Alipore College, West Bengal, India

⁴Assistant Professor, Department of Computer Science, New Alipore College, West Bengal, India

Abstract - Human Psychology is the science of mind and human behavior. So every action of human being reflects the kind of psychological actions processed through the nervous system incorporating spinal cord and brain. The very response of any situation suitable or unsuitable for the nervous system reflects its process through change in normal psychological behavior. This work analyses the responses coming from such a situation where the response intensity exceeds or remains under the threshold level. For that purpose, electro computing interfacing with the human biological system has been utilized. We have tried to understand the Human Psychology with the help of this work.

Key Words: Processor, Eyelids, Psychology, Body-temperature, Sensors, Tensed, Posture

1. INTRODUCTION

The aim of the work is to utilize the human sensories and actions to study their working mind. In our daily life, human beings are typically judging the authenticity of their words while making any statement(s). Since every action of human being is related to the brain, so we can detect the rate of authentication of their words by their action of sensories [1-3]. Here, in this work we have used human sensories as electrical inputs and process the same. The output of the process unit shows the reflection of human mind at the time of processing the instructions of the individuals. Whether someone speak by using cautiously his/ her mind or say something in random basis i.e. not thinking too much about the answer and that reflects his/her spontaneous action of the brain. The above facts may help us to contribute the scientific and technical community to understand the psychological effect in the human system while asserting any facts. There are several works have been going in this field but review of those work suggests a great cost and requires highly advanced scientific equipments[4,5] but our approach is very much cost effective with higher rate of precision at the same time also aid up to the major scientific application present in this field.

2. METHODOLOGY

In this work, we have developed an analyzing system comprised of (i) Pulse Sensor, (ii) Body temperature sensor, (iii) Human body posture sensor, (iv) Eye blinking sensor and (v) Hand movement sensor for our sensory investigation purpose. The data are accumulated from the sensory unit are being processed in highly efficient processor unit of 8 bit

compilation strength. For cost effectiveness and experimental purpose we have used Arduino Uno and Arduino Nano in array form for processing purpose. The data processed thereby are in conformity with the reviewed ones [6, 7]. The five different streams of data are processed simultaneously and in parallel thereafter fed into the master computers. The speed match between the processor external and in the computing unit is calibrated previously so error appearance in this respect was nullified. Again the most trivial issue of probe loosening are taken care of while the individual processor serial communication with the computing unit was going by so another aspect of error occurrence while executing the programming is nullified. After that process output are revealed through the Light Emitting Diodes (LEDs) for Hand movement, 5 volt piezo electric buzzer for body posture, 5 volt piezo buzzer for Eyelid Blinking and Liquid Crystal Display(LCD: I2C) unit for body temperature and pulse rate. The following are the manifestation of the processing unit shown in the Figure 1. Block diagram of these are shown in Figure 2.

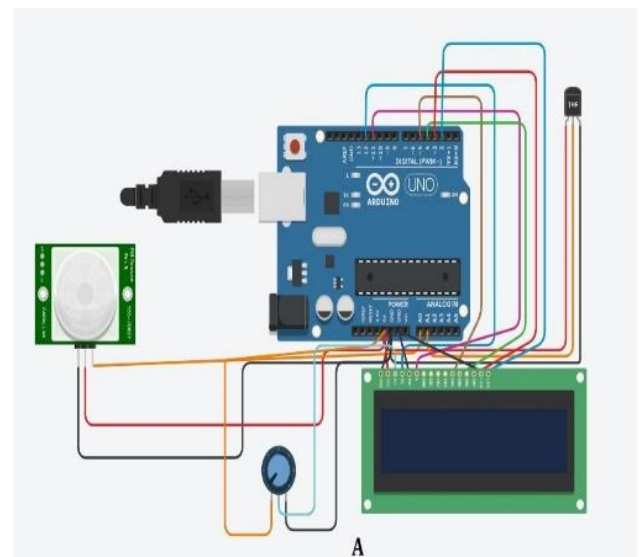

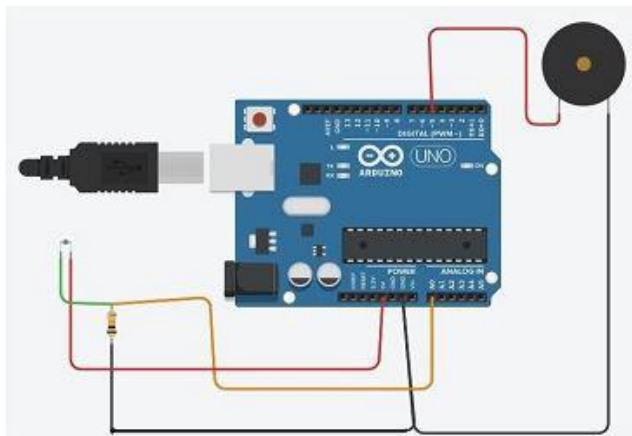

B

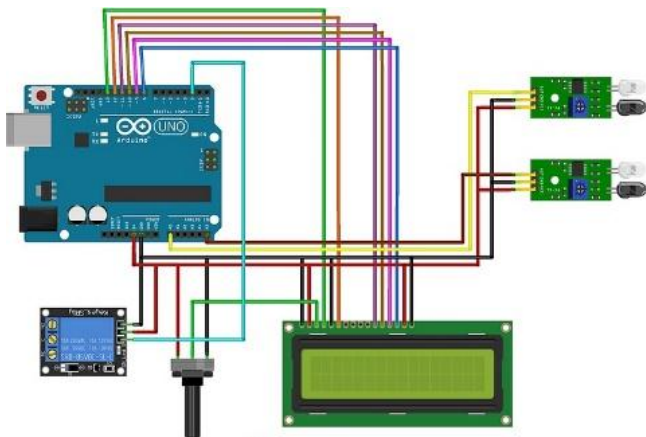

C

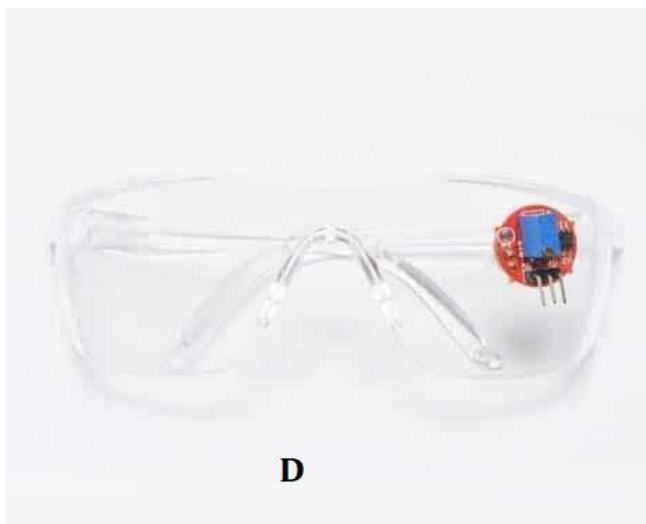

D

using the LCD display or I2c. Hence the palm part of hand is the most sensible part of a person and while we are thinking something or feel conscious for a particular topic the temp-

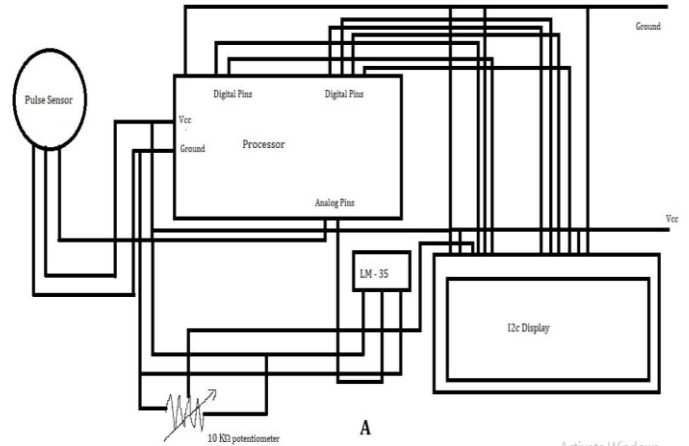

A

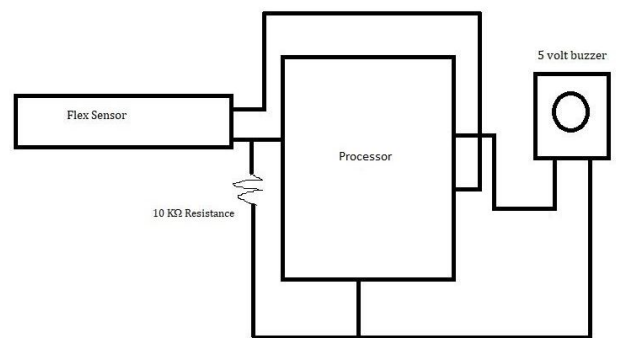

B

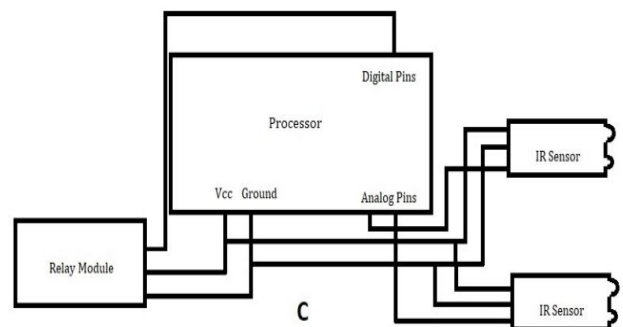

C

Fig-1: Schematic diagram of A. Pulse and temperature tester, B. Body Posture checker, C. Hand Movement checker, D. Eye Blinking Sensor

Here we have used a pulse measuring sensor (Figure-3A) in which the pulse rate of a person will be used as an input analog signal then it processed by using efficient and precised processor for measuring this and then display it by

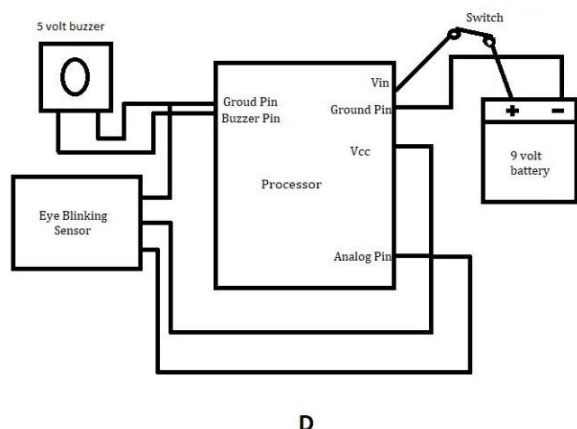

Fig-2: Block diagram of A. Pulse and Temperature Sensor, B. Body Posture Sensor, C. Hand Movement Sensor, D. Eye Blinking Sensor erature of our hand will change rapidly.



Fig-3: Pulse and temperature sensor

When a person remains his/her normal condition without having any disturbing thought or situation in his/her mind can be depicted as normal one or our threshold of psychological condition for the experiment. Then the person is said to be fit before the analyzing kit and being asked by several questions related to his/her dependencies and life which hits the primary psychological thought process of the persons involved is our stage of tension analysist.

Here we have used some IR sensors (Figure 4A) and a sensor module (Figure 4B) to sense the hand movement as well as the eyelid blinking of a person. When a person is called to move their hand near the sensor, at that very moment the sensor will read it and then a LED bulb will glow. The distance between the pupil and the eye sensor is 1inch.The sensor is so precise to calculate the posture of eye is widely or narrowly opened along with a very small blinking of the eyelid also detected by the sensor and is momentarily the buzzer buzz along with the graphical representation through master computer.

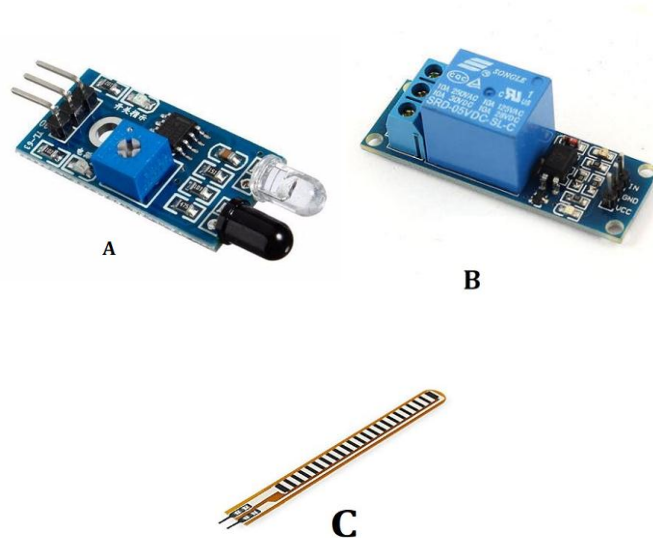
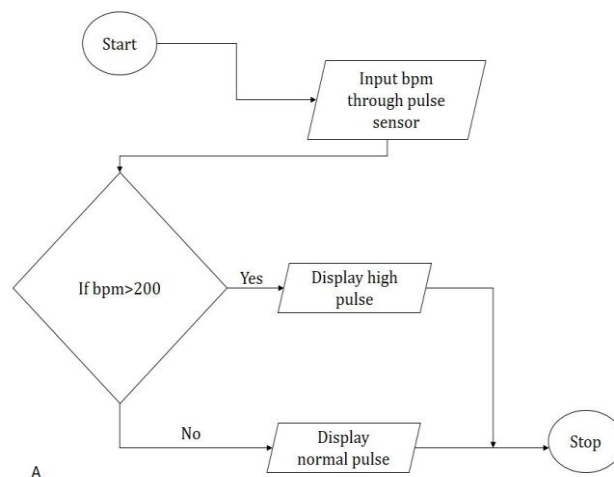

Fig-4: (A) IR Sensor, (B) Relay Module Sensor, (C)Body Posture Sensor

When a person is under psychological pressure, their eyes and hands moves and also his/her body posture will change rapidly so the flex sensor (Figure 4C) is used to detect the change in body posture.

3. RESULTS AND DISCUSSION

Here we are giving the Flow Charts for the executed program for following four processing's.



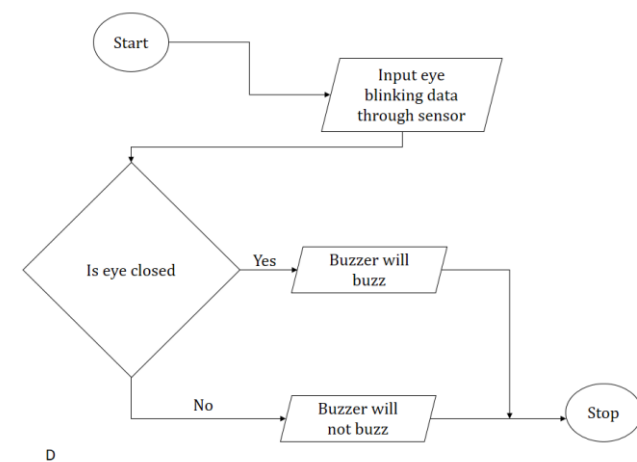
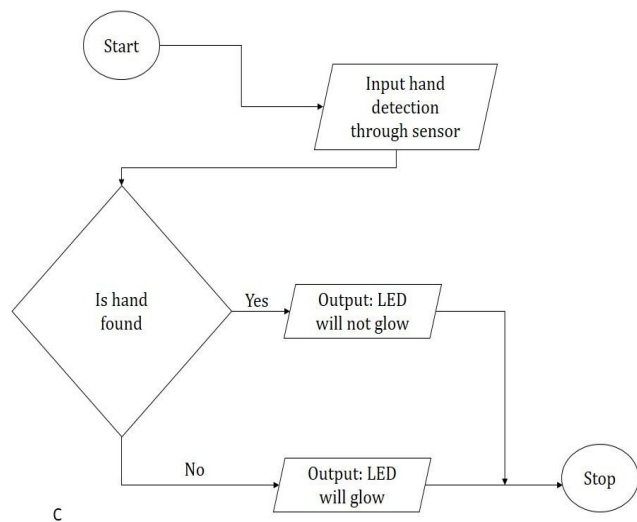
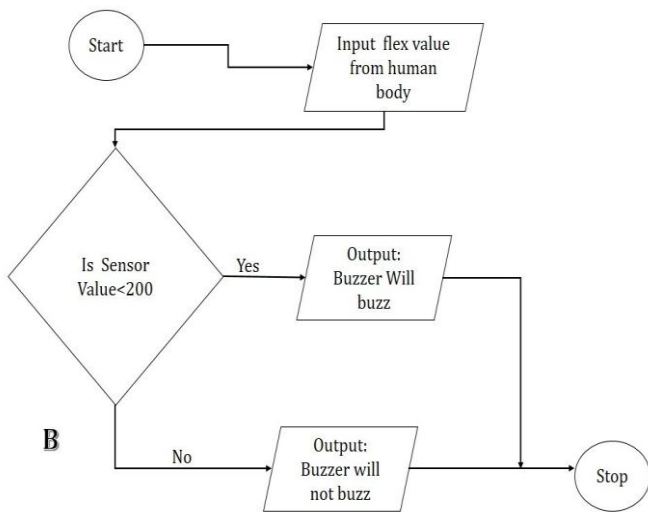

So here we have used a temperature sensor (Figure 3B) to sense the hand temperature and also both of them will display through the LCD and when the temperature as well as the pulse rate will change rapidly it will display a message that the person may be in psychological disturbed situation than its normal one which marked as tension condition and how we can distinguished between the normal condition and the tensed one are the following:

Table -1: Pulse Rate Table

Pulse Rate	Comment
<80	Low
80 – 120	Normal
120 – 150	Average
> 150	High pulse

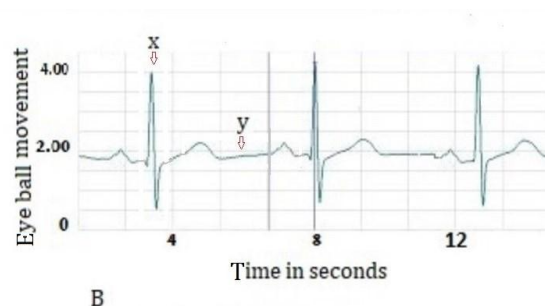
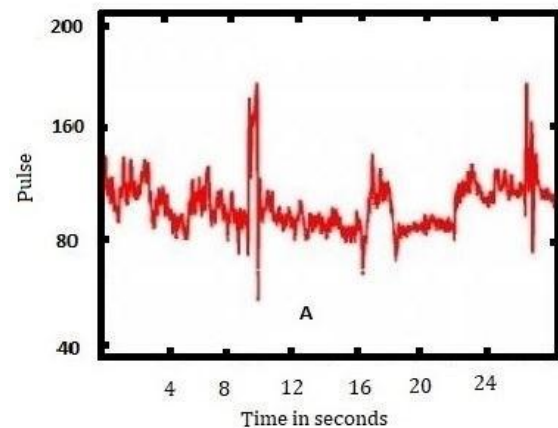

x=Eye Close Stage
y=Eye Open Stage

Fig-5: Flow Charts for the executed program

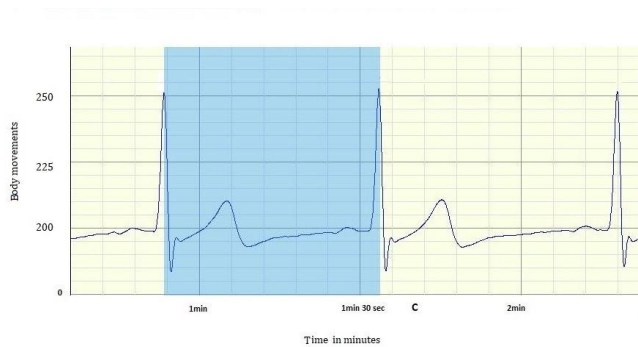

Fig-6: A. Pulse Beat Graph, B. Eye Graph, C. Body Posture Graph.

The Figure 6A shows the analysis of the pulse rate with the time. We know that pulse rate of a person is always changes with the bodily excitement. If a person is in highly excited state by physically or mentally then the persons pulse rate will varies in the random fashion. In our case mental disturbance is considered which is shown at the previous graph. Again from this analysis we have seen that a person with higher value of nervousness pulse rate will be higher than the normal person varies around 180 BPM to 200 BPM which was in conformity with the standard nervousness scale [8,10]. Similarly if a person in so much excitement then also their pulse rate will change approximately to 150 BPM to 180 BPM while initially the pulse rate starts from 72 BPM for a man and 80 BPM for women[11].

The Figure 6B shows the pattern of eyelid open or close with the time. We know that we blink our eyes due to the involuntary action of our nervous system. If a person is in highly excited state by physical or mentally the eyelid movement will varies in the random fashion. Here the case of mental disturbance is considered and is shown by the graph. Again from our analysis it is seen that with higher order of nervousness the movement of eyelid will grow faster. The sensor recognizes the instant of closing of eyelid and reflects it through buzzer.

The Figure 6C shows the movement of body. If a person is in highly excited state by it is seen that perhaps discomfort in sitting may arise. This uneasiness compels their body to execute minute movements while they sitting. In our analysis we have seen that the normal body posture rate of person is 220 to 250 taken from the sensor output as voltage per second where positional value is transduced into voltage through resistive arrangements placed in equivalent arrangement within the sensor. Another observation in this regard is that when the body bends in forward direction the posture rate shows rapid decrease and remains within the floor value of 200. Again from our analysis we have seen that when a person is in highly excited state the body posture rate will come to almost 180.

Hand is the most sensitive organ of our body [14]. So here we have used body temperature sensor. Using it we can find the temperature of that person's quite easily. We all know that 98.4 ° F is the normal temperature for person. But it is not normal temperature for our hand. Our hand's normal temperature is 85°F - 90°F[15]. Hence through the temperature sensor an analog signal from palm of the hand part of the body is given as the input. After that it will processed in the designated unit and then the result in Centigrade has been computed through the well known formula paper related to temperature conversion] and the temperature in degree Fahrenheit is generated. Here in order to find the Celsius scale temperature equivalent for computation in processor the following expression [16] is taken into consideration.

$$c = ((\text{temp}/1024.0) \times 5000)/10 \text{ (Equation-1)}$$

4. CONCLUSION

Due to fast growing social world, people suffer from mental stress and frustrations for the sake of the society and to take measure to prevent some predictable problem happening in the regular world we have tried to investigate the psychological behavior of human beings through monitoring system. The 1st phase of which is completed. This work can be used where the authenticity of the human psychology is used such as Courts, Police Station, etc. In our investigation we have found several scopes to increase the functionality of the system. The next phase of our work is under process. Some practical problem like drowsiness of the person while in driving [12] can be solved through this system will be taken care of in our future work. Another scope lies for future scope of investigation of finding the relief of the patient suffering from pains and muscular cramps.

ACKNOWLEDGEMENT

This project is funded by New Alipore College, Kolkata and the authors deeply acknowledge the institution for the funding. The authors also acknowledge the manufacturers/owners of the branded electronics/electrical devices for using their marketed products/parts in this work.

REFERENCES

- [1] E.Lab, "Introducing easy pulse: A DIY photoplethysmographic sensor for measuring heart rate," Sep. 2012, Retrieved from <http://embedded-lab.com/blog/?p=5508>
- [2] B. A. W. Mahdi, "A Blinking Measurement Method for Driver Drowsiness Detection", Springer, Proceedings of the 8th International Conference on Computer Recognition Systems CORES, , 2013, pp 651-660.
- [3] K. Ask, S.Calderon and E. M. Goila, "Human Lie Detection Performance: Does random assignment versus Self Selection of Liars and Truth-Tellers Matters?," Journal Of

Applied Research in Memory and Cognition, vol-9, issue -1, March.2020.

- [4] M. Vicianova, Historical Techniques of Lie Detection, Europe's Journal Of Psychology, vol-11, issue-2015, pp-. <https://dx.doi.org/10.5964%2Ffejop.v11i3.919>
- [5] M..R. Bhutta, M. J. Hong, Y. H. Kim and K. S. Hong, "Single-trial lie detection using a combined fNRIS-polygraph system", vol-10, issue- 07, Sep, 2015 <https://doi.org/10.3389/fpsyg.2015.00709>
- [6] R. Picard, E. Vyzas, and J. Healey "Toward Machine Emotional Intelligence: Analysis of Affective Physiological State", IEEE Transactions Pattern Analysis and Machine Intelligence Oct. 2001
- [7] J. Podlesny & D. Raskin "Physiological Measures and the Detection of Deception", Psy-chol. Bull., 1977, vol-4, pp 84:782-799
- [8] Hashem, M.M.A., R. Shams, Md. A. Kader and Md. A. Sayed, "Design and Development of a Heart Rate Measuring Device using Fingertip, International Conference on Computer and Communication Engineering" (ICCCE2010), vol-11, May. 2010.
- [9] J.H. Yang, Z.H. Mao, Member, IEEE, L. Tijerina, T. Pilutti, J. F. Coughlin, and E. Feron, "Detection of Driver Fatigue Caused by Sleep Deprivation", IEEE TRANSACTIONS ON SYSTEMS, MAN, AND CYBERNETICS—PART A: SYSTEMS AND HUMANS, VOL- 39, JULY. 2009.
- [10] Design and development of a heart rate measuring device using fingertip Computer and Communication Engineering (ICCCE), IEEE (2010), pp. 1-5 CrossRefView Record in ScopusGoogle Scholar, 2010
- [11] Shitzer, L. A. Stroschein, M.W.Sharp, R.R.Gonzalez, K.B.Pandolf "Simultaneous measurements of finger-tip temperatures and blood perfusion rates in a cold environment", Sep. 1996
- [12] M. Maiti ,T. Banerjee, and K. Chatterjee "An innovative prototype to prevent accidents using eye blink sensors and accelerometer ADXL330", Oct. 2015 INSPEC Accession Number: 15649760
- [13] M.Bali and Devendran V "Human Body Posture Recognition Using Artificial Neural Works", IJITEE, Vol-8 Issue 6S3, April 2019
- [14] R. Barba, P. de Madrid, J. G. Boticario "Development of an Inexpensive Sensor Network for Recognition of Sitting Posture", Sage Journal, Volume-11 ,Issue -8, Aug. 2015
- [15] K. Prabhavathi, K.Tamarai Selvi, K.N. Poornima, and A. Sarvanan "Role of Biological Sex in Normal Cardiac

Function and in its Disease Outcome ",Journal Of Clinical And Diagnostic Research, BE01-BE04., 20, Aug, 2014

- [16] Anguita D, Ghio A, Oneto L, Parra X, Reyes-Ortiz JL. "A public domain dataset for human activity recognition using smartphones." InEsann, pg-437-442, Apr . 2013

BIOGRAPHIES



Subham Chhatait is a studying Computer Science (Honours) in Bachelor of Science course from University of Calcutta. His research interests include hardware design and programming simulations for the design purpose.



Ashim Nandan in doing Bachelor of Science course with Computer Science Honours from University of Calcutta. He has strong interests in developing automated electro-computing devices.



Abhijit Banerjee received the B.Sc. (Honours) in Physics and M.Sc. in Electronic Science from University of Calcutta, West Bengal, India in 2006 and 2008 respectively. He did M.Tech. in Electronics and Communication Engineering (Specialization in VLSI Tech.) from IEM, WBUT, West Bengal, India in 2010 and pursuing Ph.D. in Physics from JISU, West Bengal, India. Presently he is working as Lecturer (State Aided College Teacher) in the Department of Computer Science, New Alipore College affiliated to University of Calcutta. His research interests include Radio Astronomical Physics and Communication.



Avishek Choudhury received the B. Sc. (Honours) in Computer Science from North Bengal University, West Bengal, India in 2006, the M.C.A. and M.Tech in Computer Science and Engineering from WB University of Technology, West Bengal, India in 2009 and 2013 respectively and pursuing Ph.D. in Computer Science and Technology from IEST-Shibpur, India. Presently, he is working as

Assistant Professor in the Department of Computer Science, New Alipore College, affiliated to the University of Calcutta. His research interests include fault tolerant computer architecture design and machine learning.