

“Generation of Electricity using Wind Energy Produce by Motion of Train and Used for Rural Development”

Prasad .M. Sonar¹, Sachin .M. Sangapure², Ashutosh .S. Torkhade³, Rohit .G. Bhore⁴, Ashok .S. Vavhle⁵

^{1,2,3,4,5}Student, Department of Civil Engineering, Pimpri Chinchwad Polytechnic, Akurdi, Nigdi, Pune, Maharashtra, India

Abstract - To make use of waste energy. This paper present explain on innovative method of generating clean energy using wind energy produce by motion of train. The energy generated from this method can be used for rural development and station facilities. The electricity can be generated by using the concept of the rotation of wind turbine due to wind produce by motion of train as well as natural wind. The idea is to design a wind turbine (vertical) and to installed apart along railway rails on both side at certain specific distances when the train passes the wind drives turbine and generate electricity. Power generation from railway's backward wind force using turbine can be useful and important concern in today's life because of the large train traffic density. The demand of energy is increasing day-by-day so, it's important to serve energy need for further future generation development the renewable energy is useful. This innovative method will reduce use of non-renewable source and this entire process is non-polluting.

Key Words: Wind-Turbine-Generator-Battery-Inverter-Ac supply.

1. INTRODUCTION:

Wind. This can be also used to provide electricity to villages and remote areas. These challenges can be overcome by using renewable energy which is available every day. By utilising these huge amounts of resources effectively we can overcome the deficiency of power. The turbine is defined as a type of device that transforms kinetic energy of the wind to electric power.

Green energy or wind energy which is the one of the most important sources of renewable energy that easily available in nature. At the end of this decade, most of the countries are moving towards to install more wind turbine around the world, because of the increasing need of electric power without any pollution. Wind energy is also known as green energy because it doesn't produce any pollution. To generate electricity, wind is a source of renewable energy which is present everywhere, the air can be used as a air current flowing it's a clean energy. In present day scenario power has become the major need for human life. Energy is an important input in all the sectors. The increasing population and decreasing conventional sources for power generation, it provides a need to think on non-conventional energy

resources. The main focus of our aim is to harvest a layer amount of power from railway's produces

1.1 Sub Heading 1

Before you begin to format your paper, first write and save the content as a separate text file. Keep your text and graphic files separate until after the text has been formatted and styled. Do not use hard tabs, and limit use of hard returns to only one return at the end of a paragraph. Do not add any kind of pagination anywhere in the paper. Do not number text heads-the template will do that for you.

Finally, complete content and organizational editing before formatting. Please take note of the following items when proofreading spelling and grammar:

2. PRINCIPLE:

The principle of this project is conversion of mechanical energy in the form of force into electrical energy.

3. OBJECTIVES:

- The objective of our project is to produce electricity by low price.
- In our country there is too much short fall of electricity and we try to overcome this problem by non - conventional source of electricity.
- Selection of wind turbine and generator.
- Design and manufacturing of control circuit.
- To fabricate a sustainable, innovative and environmental friendly model for electricity generation and reduce pollution.
- The main objective is to build a power generation system such that it can contribute to the present power generation system as a need of energy is growing day-by-day. The generated power is eco-friendly as well as inexhaustible means the power can be generated as long as the railways are in function.

4. METHODOLOGY:

Step1- Determination of maximum velocity of wind while the train is in motion and standing apart a rails with anemometer.

Step2- Design a wind turbine, use Dc motor as generator.

Step3- Design and preparing of control circuit.

Step4- Connection and implementation of model.

Step5- Test performance on developed prototyped model.

5. DESCRIPTION:

5.1. Selection Of Wind Turbine-

Vertical axis wind turbine (VAWT), is better to use because it requires less space to install as compared to horizontal axis wind turbine ((HAWT) and can cover the air flowing in all direction. To install turbine nearby railway rails at certain distance according to rules and regulation given by government, the Vertical axis wind turbine (VAWT) is suitable to use because of size of blades. The turbine should not be pan or oscillate due to vibration produce during the movement of train. To achieve this, turbine weight should be balance and strictly supervise during installing of turbine.



Fig -1: Prototyped Vertical Axis Wind Turbine.

5.2. Positioning:

The wind turbine should be installed at a certain distances from the rails according to rules and regulation of government. The turbine should be provided with a properly designed support and a casing for other parts to provided safety from huge wind pressure. The turbine should be installed at such a distances that it gets maximum wind from as well as natural wind and maximum power can be generated. When the train moves on average speed with producing high velocity strikes on the turbine and the rotor starts rotating. The speed of rotor also depends on

positioning of turbine installed. The turbines should be installed along parallel to rails so, that the wind flow will be continuously and also natural wind can be used. When the train moves, the turbine rotates and generates electricity. The generated electricity can be stored in the power station and can be used to station facilities but our main aim is rural development so, generated electricity will be supply to rural areas.

6. ADVANTAGES AND IMPORTANCE:

1. This project can be quite helpful in overcoming Somehow the electricity crisis.
2. By the generation we can provide electricity to areas near by the railway tracks.
3. Power generation is simple.
4. Batter used to store the generated power.
5. No pollution.
6. Less space require to install the VAWT.
7. Train produce more backward wind flow then vehicle.

7. COMPONENT DESCRIPTION:

7.1. Railway track-

A railway track, where the train travels over two parallel steel bars, called as rails. In this prototyped we made the track with aluminium.



Fig -2: Railway Track Model.

7.2. Turbine-

We used Vertical axis wind turbine. We designed our own, we made it of PVC pipe, blades of PVC pipe and shaft of PVC pipe.



Fig -3: Prototyped Turbine.

7.3. Dc Generator-

An electrical generator is a device that converts mechanical energy to electrical energy.



Fig -4: Dc Generator.

7.4. Battery-

As the turbine rotates the shaft is in motion and electric energy is generated this electric energy is passed through rectifier, this rectifier filter out and produce pure Dc supply which is need to charge the battery.



Fig -5: Rechargeable Battery.

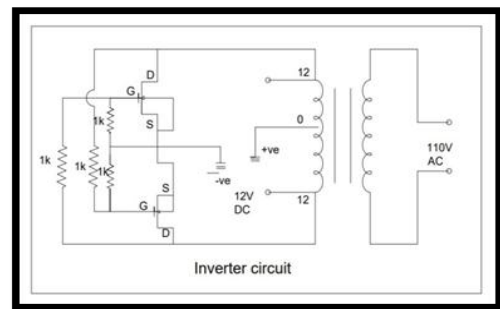

Fig -7: Control Circuit Diagram.

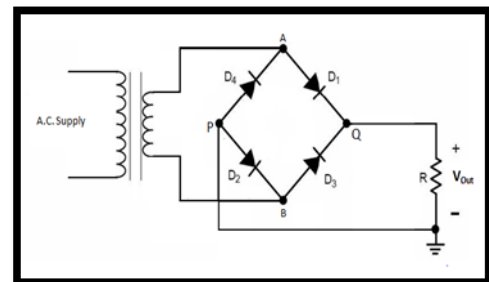

Fig -4: Rectifier Circuit Diagram.

8. DIAGRAM:

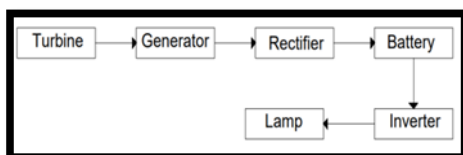

Fig -6: Block Diagram.

9. WORKING:

We have used blower to provide wind energy to the turbine as the natural wind is not available as per the site the wind is supplied to the turbine as the turbine and generator are connected to each other the generator rotates as the turbine rotates. The function of the generator is to generate electricity when shaft is in motion. As the turbine rotates the shaft is in motion and electric energy is generated this electric energy is passed through the rectifier this rectifier filter out the and produce pure Dc supply which is needed to charge the battery . To lit up the lamp we need Ac supply which is driven by inverter the inverter converts the Dc supply of battery to Ac. This Ac supply from inverter is controlled by switch by means to on and off the lamp.

10. CONCLUSIONS:

- This paper proposes an effective mean of harnessing the wind energy by the motion of the train.
- If implemented, it will meet up the power requirements for future generation.
- This method is reliable.
- Generated electricity is completely pollution free and does not have any impact on the environment.
- We suggest to all of people believe that the wind energy could soon be follow to main source of energy.

FUTURE SCOPE:

- The generated electricity can be used to village and remote areas as a rural development.
- The generated electricity can also be used to station facilities.
- The generated electricity can also be used in the train.

ACKNOWLEDGMENT:

It gives us a great pleasure to present the research paper on "Generation of electricity using wind energy produce by motion of train and used for rural development".

Special thanks to Prof. V. S. Byakod (Principal), Prof. A. A. Avasthi (HOD) and Mr. P. B. Joshi as a teaching staff of department of Civil Engineering, Pimpri chinchwad polytechnic college, for guiding us at every step and inspiring us in the field.

REFERENCES:**BIOGRAPHIES:****Prasad .Mohan. Sonar**

¹Student, Department of Civil Engineering, Pimpri Chinchwad Polytechnic, Akurdi, Nigdi, Pune, Maharashtra, India.

**Sachin .Mallikarjun. Sangapure**

²Student, Department of Civil Engineering, Pimpri Chinchwad Polytechnic, Akurdi, Nigdi, Pune, Maharashtra, India.

**Ashutosh .Sanjay. Torkhade**

³Student, Department of Civil Engineering, Pimpri Chinchwad Polytechnic, Akurdi, Nigdi, Pune, Maharashtra, India.

**Rohit .Gansham. Bhole**

⁴Student, Department of Civil Engineering, Pimpri Chinchwad Polytechnic, Akurdi, Nigdi, Pune, Maharashtra, India.

REFERENCES:

- [1] Study on the wind turbine: Yamin Sarathi.
- [2] Wind energy technology: Current status and R&D future : R. Thresher and M. Robinson
- [3] A.Ashwin Kumar, A Study On Renewable Energy Resources In India (Iccea 2010)
- [4] Bossel. U. 2008, "Alternative Energy Conversion," World academy of Ceramics European.
- [5] G. Prasanth and T. Sudheshnan, "A renewable energy approach in fast moving trains", Proceedings of the national seminar & exhibition on non- destructive evaluation NDE, 2011, pp. 232-236.
- [6] B. Sindhuja, "A proposal for implementation of wind energy harvesting system in trains," Proceedings of the 2014 International Conference on Control, Instrumentation, Energy and Communication (CIEC), Calcutta, 2014, pp. 696-702.

**Ashok .Sudam. Vavhle**

⁵Student, Department of Civil Engineering, Pimpri Chinchwad Polytechnic, Akurdi, Nigdi, Pune, Maharashtra, India.