

SMART ZONE BASED SPEED CONTROL SYSTEM FOR VEHICLES

Annamalai V¹, Krubhavarshni A², Sivanikesh S R³, Sathika J⁴, Deena S⁵

¹Student, Department of Automobile Engineering, Kumaraguru College of Technology, Coimbatore, Tamil Nadu, India.

^{2,3}Student, Department of Electronics and Instrumentation Engineering, Kumaraguru College of Technology, Coimbatore, Tamil Nadu, India.

⁴Student, Department of Electronics and Communication Engineering, Kumaraguru College of Technology, Coimbatore, Tamil Nadu, India.

⁵Student, Department of Mechatronics Engineering, Kumaraguru College of Technology, Coimbatore, Tamil Nadu, India.

Abstract - Considering the road transport data inclusive of traffic and accidents, the idea of automatic speed control is very crucial since it aims to provide maximum road safety as well as driving ease at traffic with the use of technology. In a world where everyone rushes till the nth hour, a system like this is mandatory, to automatically control the speed of any vehicle at smart zones like schools, hospitals, etc. This indeed envisions a future that is accident-free and stresses the importance of road safety and rules beyond human errors and false testimony approval. This system is designed in such a way that speed is regulated and confined at the marked smart zones with the help of the RF module. At smart zones, the RF transmitter is placed at two ends of the premises. The RF receiver in the vehicle receives the signal from the transmitter when entered into the zone which occurs due to the frequency match. ECU remapping helps in controlling the speed. This happens automatically beyond manual control when the region is committed to that particular zone. Once the vehicle leaves the zone, the driver can manually control the speed as per the traffic rules.

Key Words: RF transmitter; RF receiver; Smart zones; Controller unit; ECU remapping.

1. INTRODUCTION

Rash driving is one of the major reasons due to which accidents occur. In a current crisis of increasing the number of populations leading to serious road traffic is uncontrollable. Being in such a critical situation causes dreadful accidents and increasing accident rates. As per the stats from the World health organization (WHO), every year the lives of approximately 1.35 million people are cut short as a result of a road traffic crash. Between 20 and 50 million more people suffer non-fatal injuries, with many incurring a disability as a result of their injury. Road traffic injuries cause considerable economic losses to individuals, their families, and nations as a whole. These losses arise from the value of treatment also as lost productivity for those killed or disabled by their injuries, and for relations who got to take the day off work or school to worry for the injured. Road traffic crashes cost most countries 3% of their gross

domestic product. So, there is a much-needed change or upgrade to the current system.

In the world of the increasing population, there should increase care on road rules and safety. Generally, the crowded areas here as per the idea is marked as smart zones. These are mostly to be schools, colleges, educational and medical institutes, hospitals, crowded markets, etc. These zones have the highest human proximity, crowd, and traffic as far as the road is concerned. So there needs to be a systematic solution to ensure the utmost safety at such zones in the scope of saving several unnecessary deaths and injuries due to accidents.

Here we bring the review of the idea of automatic speed control of vehicles using RF transmitter and receiver modules. The transmitter has to be installed in smart zones where the speed limit of the vehicle has to be controlled. The transmitter will transmit a signal and the receiver has to be installed within the vehicle for speed controlling purposes. Whenever the vehicle enters the smart zone, the speed of the vehicle is decreased to some cutoff and kept constant until the vehicle leaves the smart zone. After that, the vehicle can be maneuvered by the driver based on standard traffic rules. This is our idea of a smart zone-based speed control system targeting the importance of road safety in crowded places.□

2. LITERATURE SURVEY

Automatic Vehicle Speed Reduction System Using RF Technology is developed for the prevention of an accident and also reducing the speed of vehicles by reducing the fuel supply. As the action is in terms of fuel supply, so the vehicle automatically comes under control and the accident is avoided. At curves and hairpin bends, the line of sight is not possible for those who drive, so the special kind of transmitter is tuned at a frequency of 433MHZ which continuously radiates an RF signal for some particular area [1].

Automatic Speed Control of Vehicle in Restricted Areas Using RF and GSM was used to control the speed of the vehicle using RF signal, the speed is acquired by using a

speedometer and the controller compares the speed and displays the message. If the driver doesn't respond to the message given, the information along with the vehicle number is sent to the nearest police station using GSM [2].

Design and Analysis of Vehicle Speed Control Unit Using RF Technology was implemented such that here Smart Display and Control (SDC) are designed to fit into a vehicle's dashboard and information on the vehicle. The information is collected by RFID sensors. Once the information is received the vehicle's embedded unit alerts the driver and after that, the vehicle's SDC unit automatically reduces the speed, if the driver doesn't respond to it. The microcontroller is used to control the speed of the vehicle according to zones [3].

Embedded Based Vehicle Speed Control System Using Wireless Technology proposed a system that has an alerting, recording, and reporting feature for over-speed violation management. Zigbee transmitter is used to send the speed limit of the particular lane entered by the vehicle and it also gives alerts like "road works", "steep slopes", "school zone" in the form of acoustical messages and also in LCD. An increase in the count of violation increases the penalty amount which can be collected in toll gates located nearby [4].

Limitations observed in previous works are here it is only used at humps detection, obstacle detection and steep edge detection [1], implementation can be difficult and to increase the coverage, repeaters are required to be installed [2], the dc motor is used here which has a high initial cost; cannot operate in explosive and hazard conditions due to sparking occurs at the brush of the motor [3], these systems are not independently capable of distinguishing between straight and curved parts of the road, where the speed has to be lowered to avoid accidents [4].

To overcome the above limitations, our work uses RF communication which is highly portable, easy to install, and low installation cost, it is suitable for both indoors and outdoors and it could easily distinguish the path.

3. TECHNICAL BACKGROUND

3.1 RF Transmitter

It receives the serial data and transmits to wireless RF antenna; it is used to amplify carrier wave and to modulate the carrier wave into sound or digital wave. The transmitter is stable pure sine wave low drift oscillation, the RF power amplifier, a modulator, filtering, and correctly terminated antenna. The frequency of the RF transmitter used here is 433MHz.

3.2 RF Receiver

It extracts the waves that vibrate to the desired frequency, it extracts audio signals too which were added to the waves, and also amplifies the radio signals. The transmission is occurring at the rate of 1Kbps – 10Kbps. The transmitted data is received by an RF receiver which should be operated at the same frequency as that of the transmitter.

3.3 Encoder

It is used to generate digital binary code; it has an enable pin which indicates the working. It is used to translate linear or rotary motion into a digital signal; HT12E is used to encode the data which is going to be transmitted by the RF transmitter. It is used for controlling or monitoring motion parameters. The encoder converts parallel data into serial data. The HT12E encoder is capable of encoding 12 bit of information and it consists of 8 address bits and 4 data bits. Each data input and address is externally programmable. The IC is has a wide range of operating voltage from 2.4V to 12V, but normally the VCC pin is powered by +5V.

3.4 Decoder

The decoder is mainly used in logic circuits and data transfer. HT12D is used to decode the data which is received by the RF receiver. The HT12D is used to decode the 12-bit that is received by the input pin. During this process, the serial data received by the RF receiver is converted into parallel data. The IC needed to be powered by 5V, for decoding this will need an oscillator. The 4-bit data that is received can be obtained on pins AD0 to AD3 and an address of 8-bit has to be set using the pins A0 to A7. The decoder should have the same address as that of the encoder to communicate with each other.

3.5 8051 MCU (AT89C51)

It is used for processing and internal functioning. It is an 8-bit microcontroller designed by Intel Corporation. It has 40 pins DIP (dual inline package), 4kb of ROM storage, and 128 bytes of RAM storage, two 16-bit timers. It is used in medical applications, robotics, Power theft detection, and intimation to control room using GSM.

4. PROPOSED METHODOLOGY

The proposed system is to control the speed of the vehicle within the smart zones based on the signal received from the RF transmitter which is being fixed at the entry point of the zones. Transmission through RF is best than IR due to many reasons. The signals through RF can travel through longer distances making it suitable for long-range applications. Also, while IR mostly operates in line-of-sight mode, RF signals can travel even when there's an obstruction between transmitter & receiver. RF communication uses a selected frequency, unlike IR signals which are suffering from other

IR emitting sources. On comparing with IR transmission, RF transmission is more strong and reliable; hence we have chosen RF communication for our proposed system.

The purpose of interfacing the RF receiver to the 8051 MCU is to stay at the same speed until another logic signal is received from the transmitter. The decoder output is given to the 8051 MCU which is programmed to control the speed of the vehicle through ECU remapping based on the input signal from the transmitter. The block diagrams for the transmitter and receiver side of the proposed system are shown in Fig.1 and Fig.2 respectively.

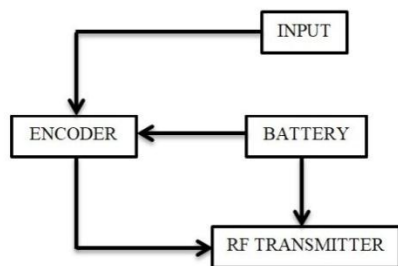

Fig -1: Block Diagram for Transmitter Side

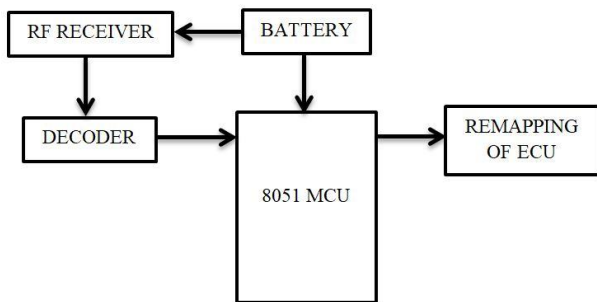

Fig -2: Block Diagram for Receiver Side

RF transmitter circuit will be fitted in both entry and exit points of smart zones. On the other hand, the RF receiver circuit will be fitted in every vehicle which is collaborated with the ECU for regulating the fuel supply.

9V battery will be used as a power supply for RF transmitters. The vehicle's 12V battery is utilized as a beneficiary for RF receiver. The operating voltage of the RF receiver is 5V; hence we use an LM7805 voltage regulator for converting the power supply from 12V to 5V. Two RF transmitters are utilized in our proposed system. The transmitter which allows the driver to travel with his desired speed is denoted by (D-Desired) while the transmitter which allows the driver to travel with low speed is denoted by (L-Low). The proposed system is implemented by fixing a pair of L and D transmitters at both the zone entry and exit points.

The transmitter constantly transmits the signal in the form of RF waves to its surrounding area up to its range. When the vehicle crosses the L transmitter, these waves are obtained in the form of a signal which is received by the RF receiver

with the help of an antenna. This signal will be sent as input to the decoder which converts serial data into parallel data. The output of the decoder is sent to the 8051 MCU. In this case, the signal is received from the L transmitter; hence the 8051 MCU will send the signal to the ECU to regulate the fuel supply such that the speed of the vehicle is reduced to 60kmph. This can be achieved through ECU remapping. While leaving the zone, the signal is received from the D transmitter, there will be no signal from the 8051 MCU to the ECU; hence the driver can travel with his desired speed according to road regulations. The flowchart for the proposed system is shown in Fig.3.

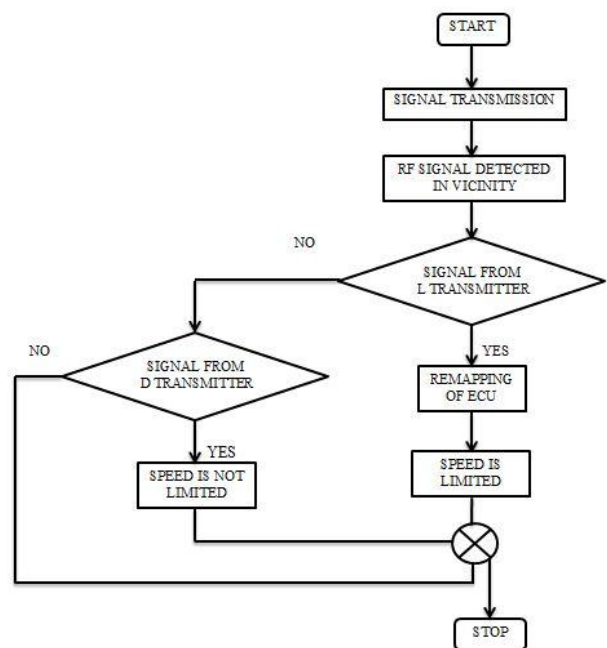

Fig -3: Flowchart

5. IMPLEMENTATION

Our target is to implement this proposed system in smart zones like schools, colleges, hospitals where the speed should be limited to 60kmph to save the life of many people. However speed limiters are installed in very few vehicles and some cases, the drivers remove the speed limiters to go fast on the roads. For this problem, every vehicle must be controlled at least in the above mentioned smart zones.

Implementation can be done by fixing the two RF transmitters in the zone starting and ending points and the RF receiver circuit in the vehicles. One RF transmitter for transmitting the signal to travel at the desired speed and another one for transmitting the signal to travel at a limited speed. In the starting point of the zone, the transmitters are fixed in the order D followed by L at a distance of 50 meters between them. On the other side in the ending point of the zone, the transmitters are fixed in the order L followed by D at a distance of 50 meters between them. According to the above arrangement of the transmitters, when the vehicle enters the zone, initially receives the signal from the D

transmitter, the driver can travel at the desired speed. Once the signal is received from the L transmitter, the vehicle speed is controlled automatically with the help of the microcontroller. This can be done by remapping the ECU. In our proposed system, the ECU of the vehicle is remapped such that when it receives the signal from the L transmitter, the microcontroller sends the signal to the ECU to limit the speed to 60kmph by reducing the fuel supply. Even though the driver presses the accelerator pedal, the fuel supply will be given only for the limited speed within the smart zones. In this way, the speed of the vehicle is controlled in the smart zones.



Fig -4: Area within the smart zone

Similar conditions will be applicable for leaving the zone also. According to the arrangement of transmitters in the ending point of the zone, the vehicle initially receives the signal from the L transmitter. Once the signal is received from the D transmitter, the driver can travel at the desired speed according to road rules and regulations. Once the vehicle is out of the zone, there will be no signal from the microcontroller to the ECU; hence there is no limitation of the speed.

6. CONCLUSION

The paper presents a solution to control the speed of the vehicle automatically using the RF signal. Here the vehicle speed is controlled automatically without the help of a driver in smart zones. We hereby conclude that this project is very easy to implement in an existing system. This imaginative strategy was created for the most part in the intention of decreasing the demise rates that are lost amid mishaps. Hence it is concluded from the above study that the uses of automatic vehicle speed control system in smart zones minimize unwanted accidents to a great extent compared to normal behavior. It is an easily conveyable and cost-efficient system. So we notify that our idea and the review of a smart zone-based speed control system is a relatively more reliable option since it overcomes the drawbacks alongside the other papers and resources.☐

REFERENCES

[1] Deepa B Chavan, Abdul Rahim Makandar, Faizul Hakeem Khan, and Syed Azimuddin Inamdar, "Automatic Vehicle Speed Reduction System Using RF Technology", International Journal of Engineering Research and Applications, ISSN: 2248-9622, Vol. 4, Issue 4, April 2014.☐

[2] A Vengadesh and K Sekar, "Automatic Speed Control of Vehicle in Restricted Areas Using RF and GSM", International Research Journal of Engineering and Technology (IRJET), e-ISSN: 2395-0056, p-ISSN: 2395-0072, Volume: 02 Issue: 09, Dec-2015.

[3] Manjunath Chincholi and Dr. K Chandrashekara, "Design & Analysis of Vehicle Speed Control Unit Using RF Technology", International Advanced Research Journal in Science, Engineering and Technology, ISSN (Online) 2393-8021, ISSN (Print) 2394-1588, Vol. 2, Issue 8, August 2015.

[4] K Govindaraju, S Boopathi, F Parvez Ahmed, S Thulasi Ram, and M Jagadeeshraja, "Embedded Based Vehicle Speed Control System Using Wireless Technology", International Journal of Innovative Research in Electrical, Electronics, Instrumentation, and Control Engineering, ISSN (Online) 2321 - 2004 ISSN (Print) 2321 - 5526, Vol. 2, Issue 8, August 2014.☐