

IOT BASED MICROGRID AUTOMATION FOR OPTIMIZING ENERGY USAGE AND CONTROLLABILITY

Dr. Lavanya Dhanesh¹, V.Aravind², R.Arunkumar², P. Jagadish Kumar², S. Shankar Narayanan²

Associate Professor¹ / EEE, & Final year EEE students

^{1,2}Panimalar Institute of Technology, Chennai

ABSTRACT: Micro grids comprise low voltage distribution systems with distributed energy resources (DER) and controllable loads which could operate connected to the medium-voltage grid or islanded in a very controlled and coordinated way. Micro grids are controlled units which report their current state to a central control unit called Central Protection Centre (CPC) thus increasing the reliability of the system. This feature also increases the controllability, security and simple power flow. By connecting load centers to a micro grid, uninterrupted power is supplied to households and industries with a reduction in energy theft, interruptions and loss in energy. However, the challenge lies in automating the complete process of monitoring, protection and control of all the grid parameters. In this paper, we propose a system to resolve the problems of microgrid reconfiguration occurring due to faults, changing energy usage patterns. By using suitable processor-based technology it's aimed to automate the system, reduce the cost and size of establishment and reduce the general cost of energy to the supplier.

INTRODUCTION

The increase in demand for energy is evident with the fact that average annual electricity consumption for a U.S. residential utility customer was 10,766-kilowatt-hours (kWh), an average of 897 kWh per month. Such numbers only signify that microgrids are the bidding solution in the current scenario. When it comes to grid features, the power supply is required to be consistent and an uninterrupted in nature. Such characteristics and reduction of transmission loss with the help of micro-sources and renewable sources such as wind, solar and hydro near to the load is attained. A great challenge lies in the protection of grid as it should respond to the fault of a utility grid as well as renewable sources. The isolation of load as well as source should be rapid in case of any fault. This rapid isolation can also create issues of selectivity and sensitivity. Thus the operation of loads with the utility grid and renewable energy resources should be easily interchangeable. In case of severe grid fault and peak hours, such sources make a significant difference in perspective of the environment and prove to be economic. Environment advantages of microgrids such as the reduction in greenhouse gases and pollutant emission are desired in current climate disruption. While the relay coordination depends on the grid, it is desired that protection and controlling of it should be smooth for which data is reported to CPC. This paper proposes an IOT based relay coordination with current and voltage sensors, which help in detecting the fault and data acquisition. Data processing is done on the cloud which substantially reduces the time of monitoring and controlling. The proposed system also reduces wires and physical connections which is economic and environmental friendly.

EXISTING SYSTEM:

The increase in demand for energy is evident with the fact that average annual electricity consumption for a U.S. residential utility customer was 10,766-kilowatt-hours (kWh), a mean of 897 kWh per month. Such numbers only signify that micro grids are the bidding solution in the current scenario. When it comes to grid features, the power supply is required to be consistent and an uninterrupted in nature. Such characteristics and reduction of transmission loss with the help of micro-sources and renewable sources such as wind, solar and hydro near to the load is attained. A great challenge lies in the protection of grid as it should respond to the fault of a utility grid as well as renewable sources. The isolation of load as well as source should be rapid in case of any fault. This rapid isolation can also create issues of selectivity and sensitivity. Thus operation of loads with utility grid and renewable energy resources should be easily interchangeable. In case of severe grid fault and peak hours, such sources make a significant difference in perspective of the environment and prove to be economic. Environment advantages of micro grids such as reduction in greenhouse gases and pollutant emission are desired in current climate disruption. While the relay coordination depends on the grid, it is desired that protection and controlling of it should be smooth for which data is reported to CPC.

PROPOSED SYSTEM:

In the proposed system a relay that consists of one sensing unit and one shifting unit is utilized. The sensor unit said in sensing the following condition such as overcurrent, overvoltage, and under-voltage. The data from the sensors is further sent to the microcontroller unit for further analysis and processing. The values obtained are compared with the threshold values fed on to the database so that any abnormal behavior of the system is notified. Immediate action is followed by the system to rectify any abnormality detected. The detection and deletion of nodes/loads happen synchronously, which

maintains the continuity and uninterrupted power supply. This extended reach helps in overcoming such complications and also monitoring of the system with energy consumption becomes effortless.

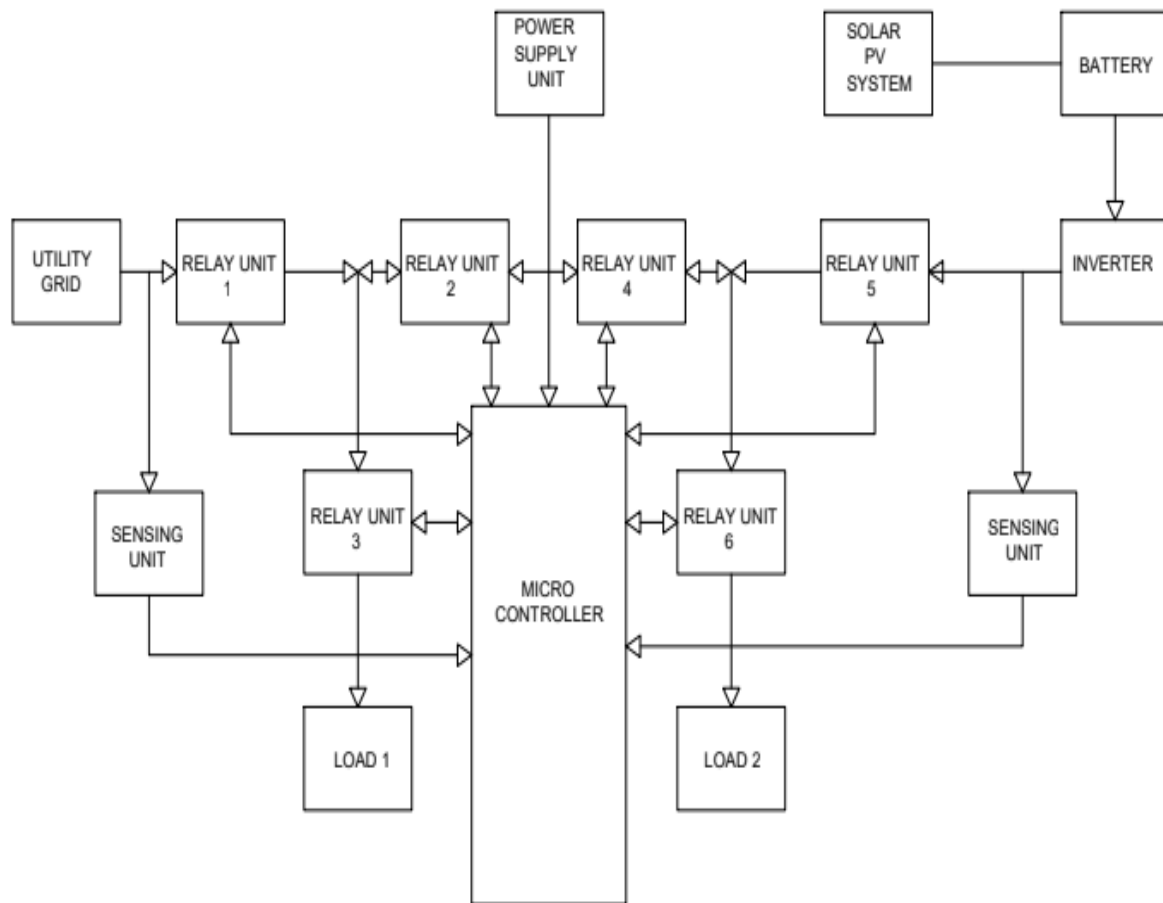

WORKING:

This system consists of the one sensing unit and one shifting unit. The sensor unit is used for sensing the following condition such as overcurrent, overvoltage, and under-voltage. The data from the sensors is further sent to the microcontroller unit for further analysis and processing. The values obtained are compared with the threshold values fed on to the database so that any abnormal behavior of the system is notified. Immediate action is followed by the system to rectify any abnormality detected. The detection and deletion of nodes/loads happen synchronously, which maintains the continuity and uninterrupted power supply. Incase if any fault is detected by the Microcontroller, the shifting unit comes into picture. By the use of the relay as the shifting unit, the supply to the load is made constant by connecting to another source available. This extended reach helps in overcoming such complications and also monitoring of the system with energy consumption becomes effortless. In the circuit diagram shown above has utility grid and solar power as the main power sources. In between the source and the Load, the sensing unit and the shifting unit is placed. The power form the solar is DC, so Battery is placed to store the D.C and then it is converted To AC by the use of the inverter.

Then it is fed to the load. As the operation of a micro grid is automated, the need for human decision making is eliminated and the minimum reaction time to react to fault conditions is drastically reduced.

The work is also focused on the issue of fault management within a micro grid exploiting the IOT. The concept of IOT is used to solve the issues of micro grid reconfiguration occurring due to faults, changing energy usage patterns and the inclusion and removal of distributed energy resources. Micro grids comprise low voltage distribution systems with distributed energy resources (DER) and controllable loads which can operate connected to the medium voltage grid or islanded in a controlled and coordinated way.

Micro grids are controlled units which report their current state to a central control unit called Central Protection Centre (CPC) thus increasing reliability of the system. This feature also increases the controllability, security and ease of power

flow. By connecting load centers to a micro grid, uninterrupted power is supplied to households and industries with reduction in energy theft, interruptions and loss in energy. However the challenge lies in automating the entire process of monitoring, protection and control of all the grid parameters.

This becomes more critical with inclusion of DERs as they are inconsistent sources of energy. In this paper the concepts of Internet of Things(IOT) is used to solve the issues of micro grid reconfiguration occurring due to faults, changing energy usage patterns and inclusion and removal of DERs. By using suitable processor based technology it is aimed to automate the process, reduce the cost and size of establishment and reduce the overall cost of energy to the supplier.

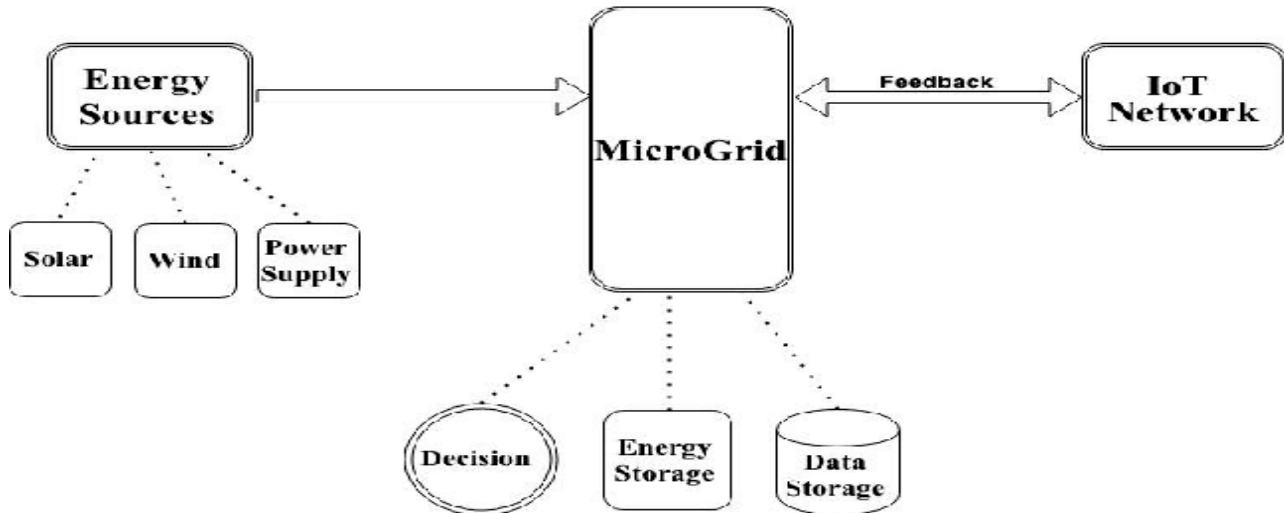

HARDWARE REQUIREMENTS:

1. POWER SUPPLY UNIT
2. MICROCONTROLLER
3. UTILITY GRID
4. SOLAR PV SYSTEM
5. BATTERY
6. Voltage sensor
7. INVERTER 8.RELAY UNIT 9.LOAD

SOFTWARE REQUIREMENTS:

1. EMBEDDED C
2. MPLAB IDE

POWER SUPPLY:

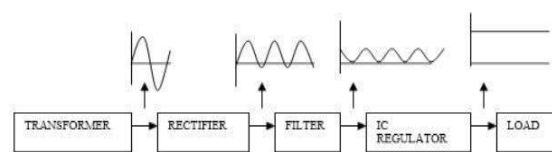

Step-down transformer is used to covert the 230v ac into 12v ac.

Rectifier will convert 12v ac into 12v dc. Filter is useful for reduce harmonic signal.

Regulator is used for 12v dc into 5v dc by ic7805. Because the microcontroller will run only in 5v.

IOT:

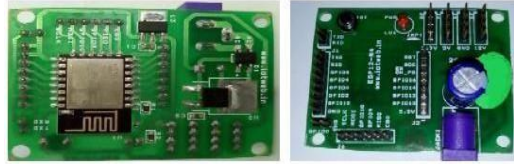

The Internet of things (IOT) is the network of every day using objects - physical things embedded with electronics, software, sensors, and connected together to enabling data exchange.

Basically, a small networked computer is attached to a thing, allowing information exchange to and from that thing.

Be it lightbulbs, toasters, refrigerators, flower pots, watches, fans, planes, trains, automobiles, or anything else around you, a little networked computer can be combined with it to simply accept input (especially object control) or to collect and generate informational output (typically object status or other sensory data).

This means computers are going to be permeating everything around us — ubiquitous embedded computing devices, uniquely identifiable, interconnected across the Internet.

Because of low-cost, networkable microcontroller modules, the Internet of things (IOT) is really starting to take off.

WEB SERVER:



CHARACTERISTICS FEATURES:

Power Supply: DC +12v 1Amp. Auto data updating: 30sec Digital Output port Pins: +5V DC

Message Format: *message or Data # (Start with * and End with #)

Provided with 3 links

Data updating to a specific web site Device controlling web site

Data updating to a social network

APPLICATIONS:

Online Traffic monitoring Online Health monitoring

Real time Transport and Logistics monitoring Daily life and domestics

MICRO CONTROLLER:

Arduino Mega 2560 is a microcontroller board supported the ATmega2560. It has 54 digital output/input pins in which 15 can be used as PWM outputs, 16 analog inputs, 4 UARTs (hardware serial ports), a 16 MHz crystal oscillator, a USB connection, a power jack, an ICSP header, and also a reset button. It needed everything that expected to support the microcontroller than connect it to a computer employing a USB cable or power it with an AC-to-DC adapter or battery to

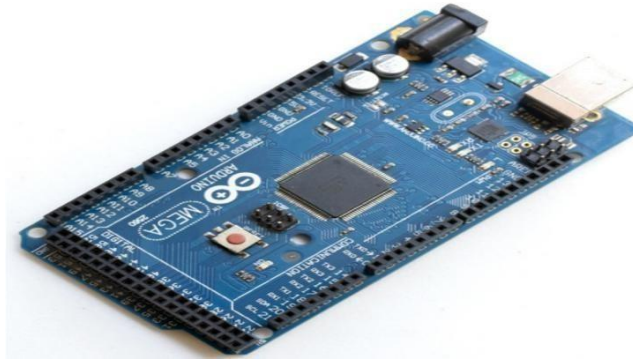
**FEATURES:**

Microcontroller: ATmega2560P Operating voltage: 5V

Input voltage: 7-12V Flash memory: 256KB SRAM: 8KB

EEPROM: 4KB

APPLICATIONS:

Real time biometrics Robotic applications

LCD:**FEATURES:**

1. Input voltage: 5v
2. E-blocks compatible
3. Low cost
4. Compatible with most I/O ports in the E- Block range
5. Ease to develop programming code using Flow code icons

APPLICATIONS:

Monitoring.



VOLTAGE SENSOR

A voltage sensor is a device that detects electric current (AC or DC) in a wire, and generates a signal proportional to it. The generated signal could be analog voltage or current or even digital output.

Features:

Supply voltage: 5v DC Output: analog

Small size Low cost

This is an LCD Display designed for E-blocks.

It is a 16 character, 2-line alphanumeric LCD display connected to one 9-way D-type connector. Then it allows the device to be connected to E- Block I/O ports. The LCD display requires data during a serial format, which is detailed within the user guide below. The display also requires a 5V power supply. Please take care not to exceed 5V, as this will cause damage to the device. The 5V is generated from the E-blocks Multi programmer or a 5V fixed regulated power supply.

Applications:

Ammeters

Current control purposes

CHARACTERISTICS

Low cost

Low power consumption Low data rate

Scalability Reliability

RELAY CIRCUIT:

An electromechanical switch called a relay which is activated by an electrical current. A single relay board arrangement contains power supply circuit, driver circuit and isolation circuit. A relay is assembled with that circuit. The driver circuit uses transistors for switching operations and this transistor is used for switching the relay. An isolation circuit blocks the reverse voltage from the relay which protects the transistor and controller from damage. The given input pulse for switching the transistor is from the microcontroller unit. It is for switching of four devices

FEATURES:

Input voltage: 12VDC Driver unit: ULN2003A Isolation unit: In4007 Fast switching

Motor forward and reverse operation

APPLICATIONS:

Ac load Switching applications Dc load Switching applications Robotic applications



DC MOTOR:

Geared dc motors are often defined as an extension of dc motors. A geared DC Motor features a gear assembly attached to the motor. The speed of the motor is measured in terms of rotations of the shaft per minute and is termed as RPM. The gear assembly used for increasing the torque and reducing the speed. Using the right combination of gears during a gear motor, its speed is often reduced to any desirable figure. This concept where gears reduce the speed of the vehicle but increase its torque is known to be gear reduction.

FEATURES:

Supply voltage: 12VDC Speed: 100rpm

Long Lifetime, Low Noise, Smooth Motion

APPLICATIONS:

Coin Changing equipment Peristaltic Pumps Damper Actuators

Fan Oscillators



BATTERY:

Batteries are often charged manually with a power supply featuring user-adjustable voltage and current limiting. 12v 7.5Ah lead-acid battery is a rechargeable battery that supplies electrical energy and these batteries are designed to release a high burst of current and then recharged quickly. Six cells are connected in series in this battery.

FEATURES:

Output voltage: (12-12.6) v DC Current capacity: 7.5Ah

Low self discharge Long life

APPLICATIONS:

Automobiles

UPS

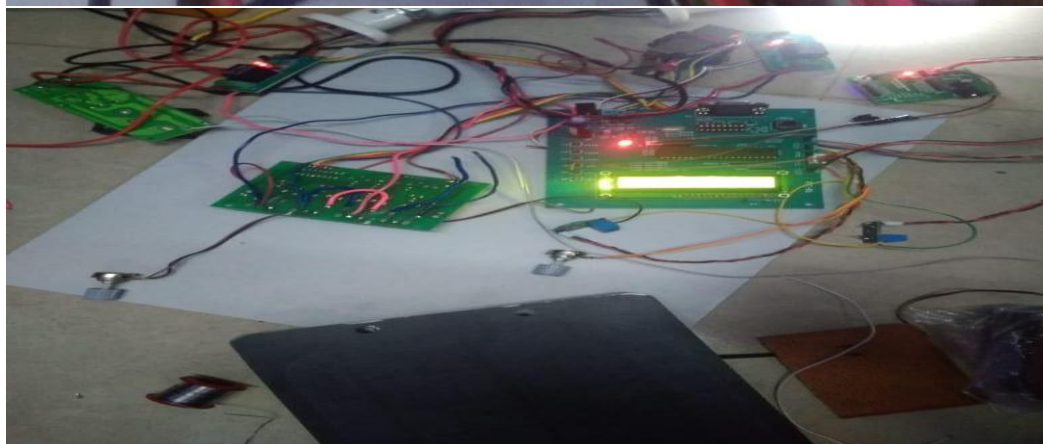
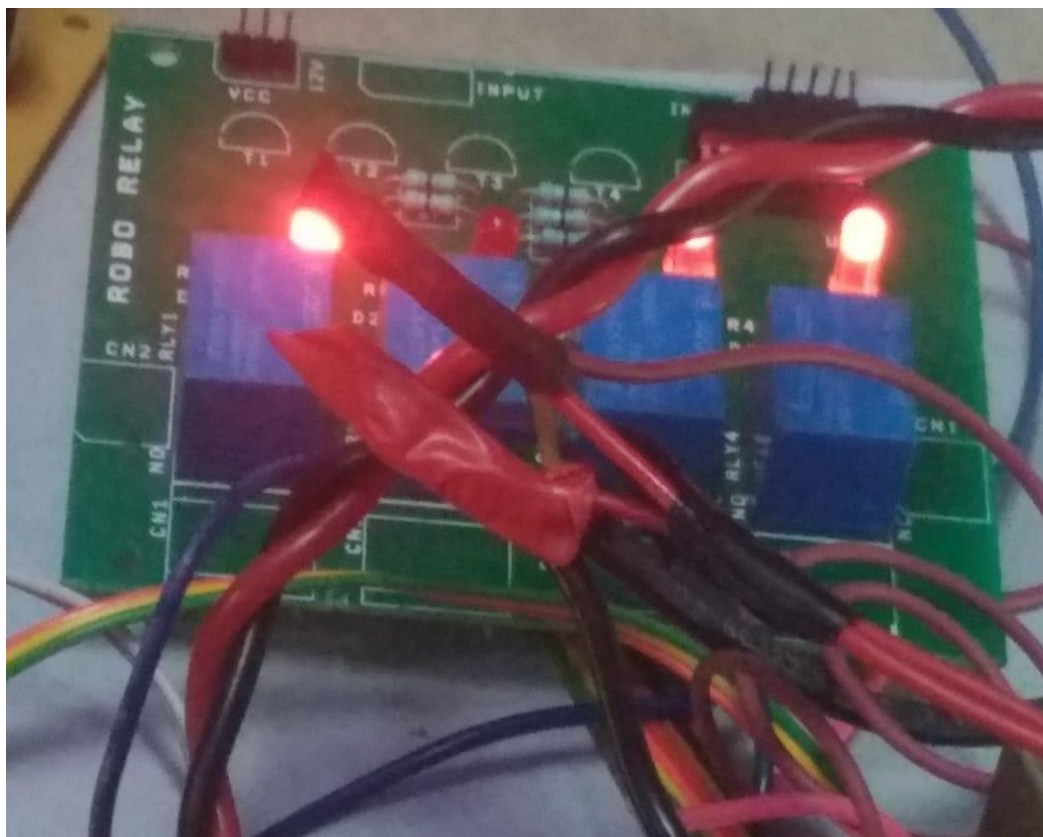

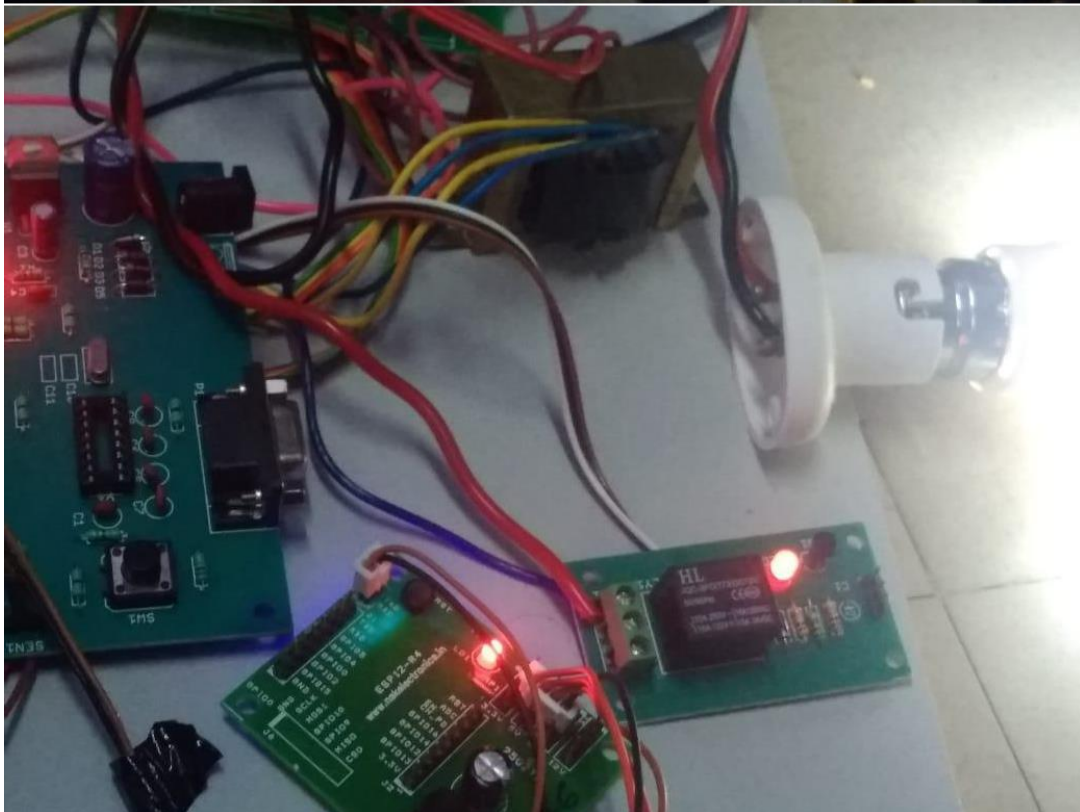
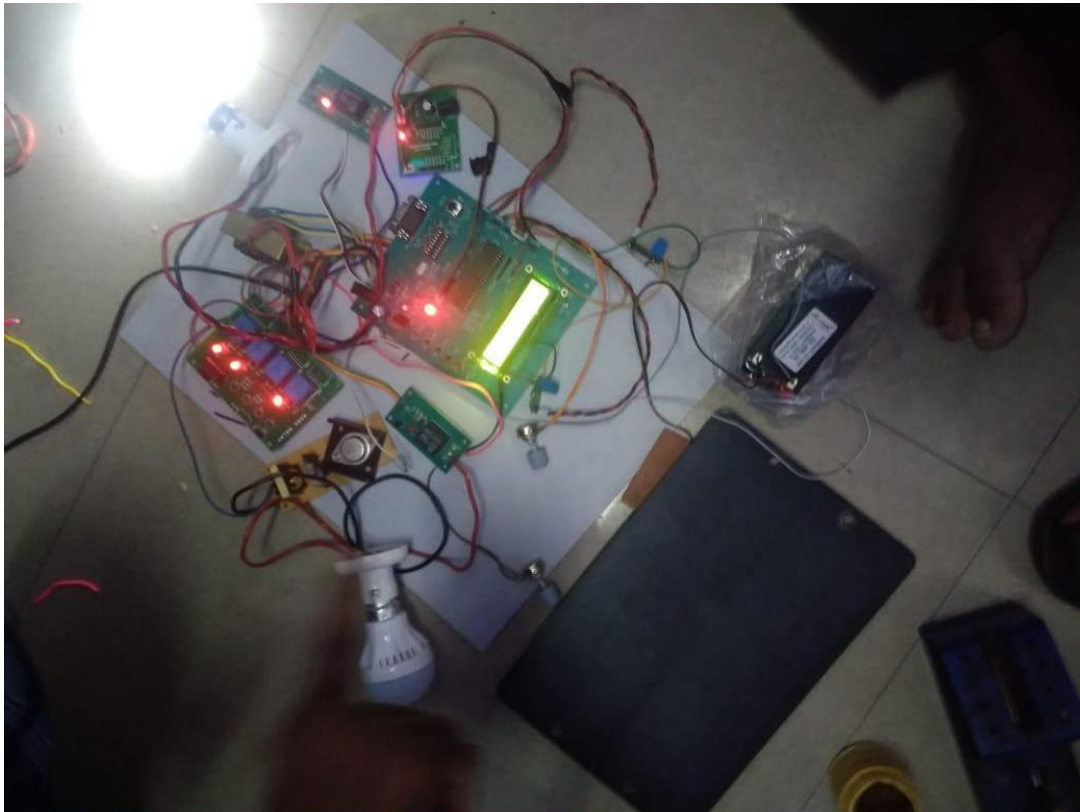

CONCLUSION:

With growing rapid development and dependency on renewable energy resources in microgrid, its protection and command can be resolved with the help of IOT. This continuous operation and automation of system allows optimize energy and monitoring the status of the system. The IOT grants the system advantage to remotely observe and supervise the network. In this paper, IOT was incorporated in microgrids to monitor and protect the network in both grid connected and islanded modes of operation. Additionally source switching based on energy pattern was realized. With inclusion of more sources and loads in the system, more safe and continuous supply is ensured due to prioritizing based operation. This application on test bench is evidence of its potential in automation and energy optimization of microgrid.

REFERENCES:

1. B. Zhang, Z. Hao, Z. Bo, "New development in relay protection for smart grid," Protection and Control of Modern Power Systems, vol. 1, no. 1, pp. 1-7, Nov. 2016.
2. X. Liu, A. H. Osman and O. P. Malik, "Hybrid traveling wave/boundary protection for monopolar HVDC line," IEEE Transactions on Power Delivery, vol. 24, no. 2, pp. 569-578, Apr. 2009.
3. S. Zhang, B. H. Zhang, M. You and Z. Q. Bo, "Realization of the transient-based boundary protection for HVDC transmission lines based on high frequency energy criteria," Proc. International Conference on Power System Technology, 2010, pp. 1-7.
4. N. Zhang and M. Kezunovic, "Transmission line boundary protection using wavelet transform and neural network," IEEE Transactions on Power Delivery, vol. 22, no. 2, pp. 859-869, Apr. 2007.
5. S. Luo, H. Gao, D. Wang, G. Zhou, "Non-unit transient based boundary protection for UHV transmission lines," International Journal of Electrical Power & Energy Systems, vol. 102, pp. 349-363, Nov. 2018
6. F. B. Costa, B. A. Souza and N. S. D. Brito, "Effects of the fault inception angle in fault-induced transients," IET Generation, Transmission & Distribution, vol. 6, no. 5, pp. 463-471, May 2012.
7. J. A. S. B. Jayasinghe, R. K. Aggarwal, T. Johns and Z. Q. Bo, "A novel non-unit protection for series compensated EHV transmission lines based on fault generated high frequency voltage signals," IEEE Transactions on Power Delivery, vol. 13, no. 2, pp. 405-413, Apr. 1998.
8. B. Zhang, H. Ha, J. Duan and Z. Bo, "Boundary protection, a new concept for extra high voltage transmission lines, Part II: Discriminative criterions and simulations," Proc. 2005 IEEE/PES Transmission and Distribution Conference and Exhibition: Asia and Pacific, Dalian, 2005, pp. 1-5.
9. X. N. Lin, Z. Q. Bo, B. R. J. Counce and N. F. Chin, "Boundary protection using complex wavelet transform," Proc. Sixth International Conference on Advances in Power System Control, Operation and Management ASDCOM, 2003, pp. 744-749.
10. J. Duan, K. Jun and S. Wu, "Boundary protection algorithm based on phase information of improved recursive wavelet transform for EHV transmission lines," Proc. Asia-Pacific Power and Energy Engineering Conference, 2009, pp. 1-4.
11. Lavanya Dhanesh and Dr.P.Murugesan, "Smart Scheduling of the Real-Time Tasks Using the Cyclic Priority Preemptive Pipeline Scheduling Algorithm" in the International Journal named "Journal of Computational and Theoretical Nano Science" ISSN 1546-1955 Volume 14, Number 3, pp.1-8.
12. Deepa S., Samuel rajeshbabu., Ranjani(2014) "A Robust Statcom Controller Using Particle Swarm Optimization", IJE TRANSACTIONS B: Applications. Vol. 27, No. 5 pp.731-738.
13. R.Dharmaprakashand Joseph Henry, "Direct Torque Control of Induction Motor Using Three- Level Diode Clamped Multilevel Inverter", International Journal of Applied Engineering Research, Vol.9, No.19, 2014, pp 5985-5998
14. Lavanya Dhanesh and Dr.P.Murugesan, "Power Saving of The CPU By Improving The Performance of The Real - Time System Kernal Using The PSCPPTS Algorithm" in the International Journal named "International Journal of Applied Engineering Research" ISSN 0973-4562 Volume 10, Number 5 (2015) pp. 12465-12473.

15. C.T.Manikandan, Performance Analysis of Solar Based High Stepup DC-DC Converters with Various Filters, 2018 IEEE International Conference on Computational Intelligence and Computing Research (ICCIC), 13 to 15 Dec 2018
16. Lavanya Dhanesh and Dr.P.Murugesan, "Analysing the WCET by implementing Cyclic Priority Pre- Emptive Task Scheduling algorithm" in the International Journal named "Far East Journal Of Mathematical Sciences" ISSN 0972-0871 Volume 97,Number 6, 2015 pp.667-688.
17. M. Padmarasan, R. Samuel Rajesh Babu, "MSRF Control Based Interline Dynamic Voltage Restoration in Distribution Line", International Journal of Recent Technology and Engineering, Volume-8 Issue-5, pp.1-5
18. Lavanya Dhanesh and Dr.P.Murugesan, "A Novel Approach in Scheduling Of the Real- Time Tasks In Heterogeneous Multicore Processor with Fuzzy Logic" in the International Journal named "International Journal of Power Electronics and Drive System (IJPEDS)" ISSN: 2088-8694, Vol. 9, No. 1, pp. 80-88.