

DESIGN OF SMART SANITIZING WATCH

Yash Gangwal¹, C. Sai Manish Reddy², Gauri Wadyalkar³, Santhiya E⁴,

Fahima Jafeen.A⁵, Puskar Shekhar Tambe⁶, Manasi Chaudhari⁷, Shwetambari Thakare⁸

¹Student, Mechanical Engineer, Medi-Caps University, M.P., India

²Mechanical Engineer, CMR College of Engineering and Technology, Hyderabad, Telangana, India

³Student, Electronic and telecommunications, Bharti Vidyapeeth's college of engineering for women Pune University, Maharashtra, India.

⁴Student, Electronics and Communication Engineer, BS Abdur Rahman Crescent Institute of Science and Technology, Chennai, India

⁵Student, Electronics and communication engineer, B.S Abdur Rahman crescent institute, Tamilnadu, India

⁶Student, Information Technology, K. J. Somaiya College of Engineering, Maharashtra, India

⁷Student, Electronics and Telecommunication Engineer, MIT Academy of Engineering, Pune, India

⁸Student, Electronics and Telecommunication Engineer, MIT Academy of Engineering, Pune, India

Abstract: In the current scenario of global pandemic, to prevent the spread of contagious diseases like COVID-19 (corona virus disease) people are mandated to wear personal protection equipment like face masks & face shields and practice social distancing and practice regular hand sanitizing. In these hard days of lockdowns and quarantines most of the activities like working, shopping and studying are taking place at homes. However, we all have to leave home from time to time for essential needs and increase exposure of infection by coming in contact with infected persons and commonly touched surfaces or objects that might be contaminated. To lower the chances of infection we need a quick and immediate way of sanitizing. The people subjected to the COVID-19 are quarantined and their vitals such as temperature, heart rate and oxygen levels are frequently monitored. The main motive of this project is to design a Smart Protective equipment/device that can measure the user's skin temperature, heart rate and includes hand sanitation through the use of alcohol based sanitizer for daily use by people while travelling to work places, shopping etc. The objective of this project is to design a low-cost wearable device that can perform the afore mentioned functions. This project uses Solid Works, Autodesk Fusion 360 for design of the device and Arduino IDE for control and programming. The wearable device functions as a smartwatch with detachable sanitizer module.

Key Words: corona virus, COVID-19, Smart Protective Gear, Personal Protection, Sanitation, Temperature, Heart rate, wearable device, biometric sensors, smartwatch, sanitizer module.

1. INTRODUCTION

In the current situation of COVID-19 global pandemic practices of wearing face masks, regular hand sanitation and social distancing have become a part of our daily lives. People travelling to and from workplaces, using elevators and shopping at supermarkets come into contact with commonly touched surfaces might need immediate sanitization of their hands. Nowadays hand sanitizers are commonly available at workplaces, supermarkets and hospitals etc., but the dispenser placements may be sparse and people may not have immediate access when needed.

This might be the reason people choose to carry their own personal sanitizers, but they are limited to containers/bottles that can be carried in pocket or purse. But remembering to always grab and carry around a sanitizer bottle would be an additional task/responsibility. So, it would be beneficial if a device that may be worn by a user to facilitate ready access to a hand sanitizing material at any time and in any setting, and which dispenses the sanitizing material by a means which does not leak or stain clothing, or is subject to misuse by children, or which results in re-contamination

of the hands following use. So it is simpler if sanitizer can always be worn as bracelet or a watch/band.

Monitoring of vitals such as heart rate, temperature and oxygen levels in blood of patients symptomatic/asymptomatic is being done regularly at hospitals, quarantined centers or home quarantined patients. The device configured as smartwatch with sanitizer aims to perform all the above mentioned functions.

1.1 Smartwatch

Smartwatches are the wearables which account for largest share of end-consumer spending globally and are expected to keep growing. A smartwatch can hold all the sensors that can be used to measure and monitor all the biometrics/vitals of the wearer.

1.2 Sanitizer Module

A sanitizer module is designed so that it can be worn along with the smartwatch. This is a refillable sanitizer module which can be made using recyclable plastic and can hold up to 25ml of alcohol based sanitizer.

2. LITERATURE REVIEW

Few research papers and products related to wearable hand sanitizers and smartwatches have been reviewed and the following references show influence of the design and working of Smart Protective Gear.

Darcy W. Greep [1] has proposed various ways of designing a wearable sanitizing device that can be structured as a pen, or an item worn as jewelry, ring bracelet, watch-like member or belt buckle.

Xiao Li, Dunn, J., Salins, D., Zhou, G., Zhou, W., Schüssler-Fiorenza Rose, S. M., Perelman, D., Colbert, E., Runge, R., Rego, S., Sonecha, R., Datta, S., McLaughlin, T., Snyder, M. P [2] have made a study that states it is possible to detect infection using data — specifically, data from a change in heart rate — from a smartwatch. Their study showed that specific patterns of heart rate variation can indicate illness, sometimes even while the individual is asymptomatic.

Michael Snyder, PhD, professor and chair of genetics at the Stanford School of Medicine[3] aim to detect early signs off viral infection through data from smartwatches and other wearable devices. Snyder and his team of researchers seeks to train a series of algorithms by using wearable devices to measure things such as heart rate and skin temperature, which are known to elevate when the body is fighting off an infection. Devices with an algorithm could alert users when their heart rate, skin temperature or some other part of their physiology signals that their body is fighting an infection.

The scope of the present study is to design Smart wearable sanitizer by exploring the biometric sensors that are required for monitoring a person’s vitals. The wrist would be an ideal place for performing the functions for sanitizing and monitoring a person’s vital.

3. DESIGN

The goal of the project is to design a smart sanitizing device that can be easily integrated into a person’s daily lifestyle. Smartwatches are the most commonly used electronic gadgets that are used by most people. So a smartwatch that can also help in sanitizing would meet the requirements of measuring vitals of the user and sanitizing.

The design of the smart sanitizing watch is done such that the watch dial faces the upper side of the arm wrist and the sanitizer module on the lower side of the arm wrist. A minimalistic approach is adopted for the design of the product.

3.1 Mechanical Design

The watch case/dial of 44 x 38 x 10.5 mm is made up of plastic was modeled in Solid Works. The dial is made to accommodate a 1.5inch IPS LCD touch display and has

been provided with an opening at the back for the functioning of temperature sensor and the led lights of the heart rate sensor. In order for proper functioning of the sensors placed at the back a transparent plastic plate is provided at the back cover of the case. Two buttons are provided on one side of the case and a slot is provided for USB-charging on the other side. To minimize the number of parts of the watch the dial case is built with attached lugs for accommodating a standard 24mm silicone/synthetic strap which can be fitted to the lugs with spring bars. The design of the smartwatch is shown in the figures 1 and 2.



Fig -1: Rendered front view of the smartwatch

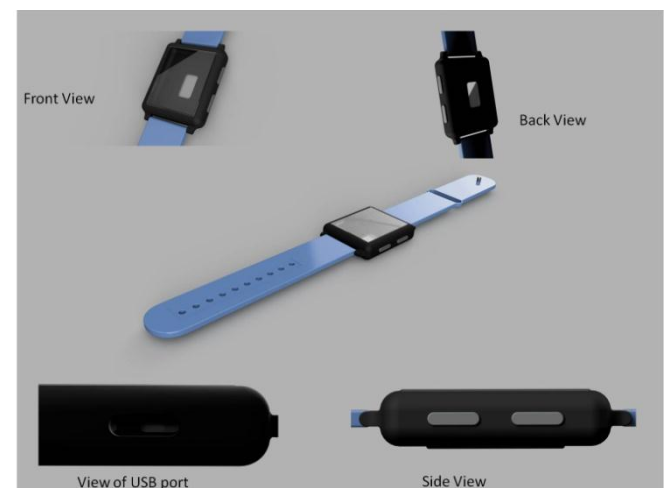

Fig -2: Rendered views of the smartwatch in Fusion 360

A rectangular shape compartment is chosen for the container where the nozzle of the spray is pointed towards the palm of the wearer. A mechanical spray is employed for spraying the sanitizer in the form of mist. The container consists of a cylinder, piston, spring, non-return valve, tube, nozzle and a button protruding out in the opposite direction of the wrist. The spray is dispensed onto the wearers hand when the button is pressed. A lid is provided at the back of the container to refill the sanitizer. The sanitizer module is provided with lugs in the form of a loop, at the base of the container for attaching a strap. This sanitizer module can be mounted on the underside of the wrist by inserting the straps of the watch through the lugs provided at the module’s base. This feature is provided so the user can attach or detach sanitizer module upon his/her will. Figure-3

shows the views of the sanitizer module designed and rendered in Fusion 360.

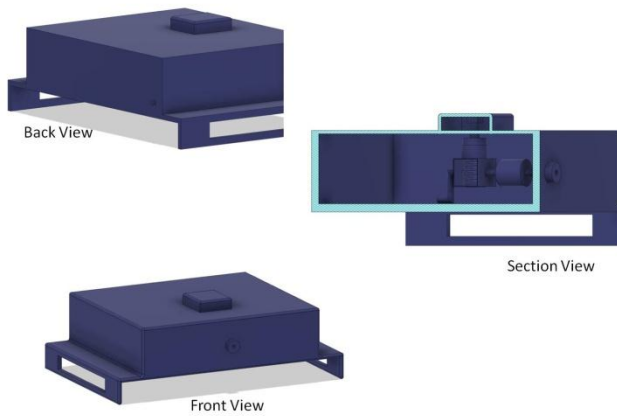

Fig -3: Rendered views of the sanitizer module

The assembled view of the watch and sanitizer module can be seen in the figure 4 & 5.



Fig -4: Smart Sanitizing Watch

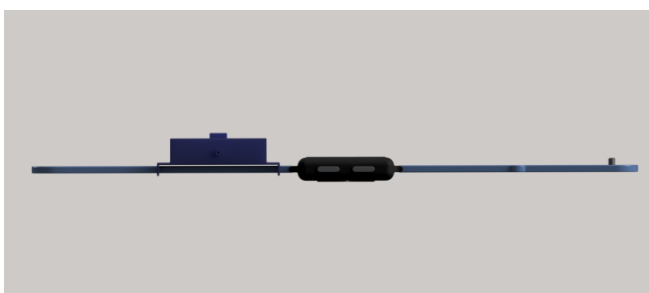

Fig -5: Side View of Smart Sanitizing Watch

The key mechanical components in the product and the material selected for the manufacturing of those components are listed in Table-1.

Table -1: List of mechanical components

Mechanical Components	Quantity	Material
Watch Case	1	Recyclable Plastic
Spring Bars	2	Stainless Steel
Long Strap	1	Silicone Rubber
Buckle Strap	1	Silicone Rubber
Buckle pin	1	Stainless Steel
Buttons	2	Plastic/Aluminium
Front Glass	1	Glass
Back Glass	1	Transparent Plastic
Sanitizer Compartment	1	Recyclable Plastic
Cylinder	1	Recyclable Plastic
Piston	1	Recyclable Plastic
Push Button	1	Recyclable Plastic
Spring	1	Stainless Steel

3.2 Electronics and hardware

The electronic and hardware of the watch plays a prominent role in measuring various vitals of our body and displaying them on the LCD screen.

3.2.1 Components

Arduino pro mini

The Arduino Pro Mini is a microcontroller board based on the ATmega328. It has 14 digital input/output pins (of which 6 can be used as PWM outputs), 6 analog inputs, an on-board resonator, a reset button, and holes for mounting pin headers. A six pin header can be connected to an FTDI cable or Sparkfun breakout board to provide USB power and communication to the board. The size of the controller is (18*33*0.8) mm.



Fig -6: Arduino Pro Mini

Temperature sensor (MLX 90614)

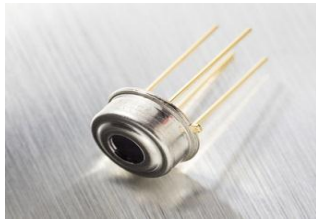

Fig -7: Temperature Sensor

The MLX90614 is an Infra Red thermometer for non-contact temperature measurements. Both the IR sensitive thermopile detector chip and the signal conditioning ASSP are integrated in the same TO-39 can.

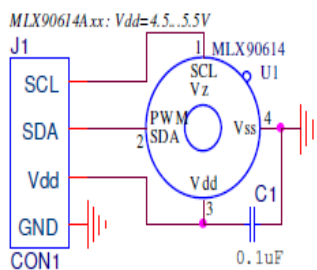

Fig -8: MLX90614

Operating temperature range: -40 to +80°C

Storage temperature range: -40 to +120°C

Pulse Oximeter heart rate sensor (MAX 30100)



Fig -9: Pulse Oximeter & Heart Rate Sensor Module

MAX30100 is an integrated pulse oximeter and heart-rate monitor sensor solution. It's an optical sensor that derives its readings from emitting two wavelengths of light from two LEDs – a red and an infrared one – then measuring the absorbance of pulsing blood through a photodetector. This particular LED colour combination is optimized for reading the data. It is fully configurable through software registers and the digital output data is stored in a 16-deep FIFO within the device. It has an I2C digital interface to communicate with a host microcontroller. The input voltage ranges from 1.8V to 5.5V.

Accelerometer and Gyroscope Sensor:



Fig -9: Gyroscope and Accelerometer Sensor module

MPU6050 module uses the popular MPU6050 Sensor which includes both a 3 axis accelerometer and a 3 axis gyroscope in a single package. The sensor can be interfaced through a I2C connection which allows an easy and direct interface between the sensor and a micro controller. MPU-6000/MPU-6050 family of parts are the world's first and only 6-axis Motion Tracking devices designed for the low power, low cost, and high performance requirements of smart phones, tablets and wearable sensors.

Wi-Fi Bluetooth module (ESP WROOM 32D)



Fig -11: ESP WROOM 32D

ESP-WROOM-32D is a powerful, generic Wi-Fi+BT+BLE MCU module that targets a wide variety of applications. The integration of Bluetooth, Bluetooth LE and Wi-Fi ensures that a wide range of applications can be targeted, and that the module is future proof: using Wi-Fi allows a large physical range and direct connection to the internet through a Wi-Fi router, while using Bluetooth allows the user to conveniently connect to the phone or broadcast low energy beacons for its detection. The sleep current of the ESP32 chip is less than 5_A, making it suitable for battery powered and wearable electronics applications. ESP32 supports a data rate of up to 150 Mbps, and 20.5 dBm output power at the antenna to ensure the widest physical range. The size of the module is (18*19.2*3.2) mm.

Battery (Lithium polymer)

A lithium polymer battery, or more correctly lithium-ion polymer battery (abbreviated as LiPo, LIP, Li-poly, lithium-poly and others), is a rechargeable battery of lithium-ion technology using a polymer electrolyte instead of a liquid electrolyte.

Voltage: 3.7V

Capacity: 500mAH



Fig -12: LiPo Battery

LCD display: (1.5 inch IPS)



Fig -13: IPS LCD touch Display

The resolution of the screen is 240 x 240. The LCD display is of Thin Film Transistor (TFT). The brightness of the screen is 400cd/m².

Ambient light sensor

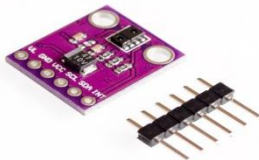

Fig -14: Ambient Light Sensor

Ambient light sensor is a photodetector that is used to sense the amount of ambient light present, and appropriately dim the device's screen to match it. The size of the device is 3.2cm*1.7cm. The working voltage of the device is 3.5V-5V.

Micro USB connector B type:



Fig -15: Micro USB

The B-style connector is designed for use on USB peripheral devices. The B-style interface is squarish in shape, and has slightly beveled corners on the top ends of the connector.

3.2.2 Circuit Diagram

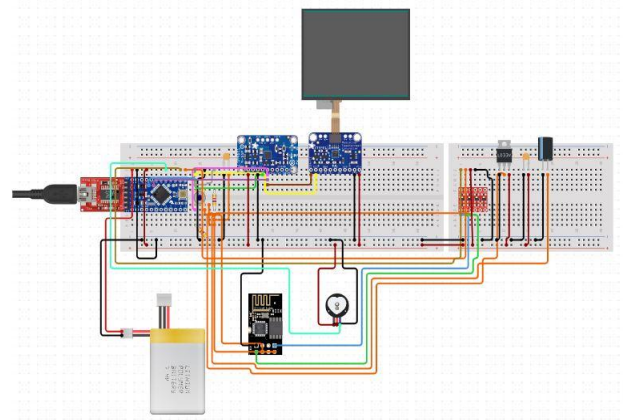

Fig-16: Electronic circuit

4. WORKING

The device functions as a regular smartwatch, it tracks the physical activity of the user with the aid of accelerometer sensor. Monitoring of wearer's temperature is done using the IR temperature sensor positioned directly pointing onto the wrist. Heart rate and oxygen levels in the blood are measured by the pulse oximeter heart rate sensor using a phenomenon called photoplethysmography.

The sanitizer module should be filled with alcohol based sanitizer and then strapped to the watch. Sanitizer can be sprayed on to the palm or any other object it is pointed towards by simple push of the button. As small amount of sanitizer is dispensed with each spray, it can be sprayed upto 100 times.

5. CONCLUSION & FUTURE SCOPE

The design of the smart sanitizing watch has been presented in this paper. Wearing this product simplifies the task of hand sanitizing at any time and in any setting. The chances of re-contamination of the dispenser and leakage are very low. The material has been chosen considering environmental factors and the components are designed and selected considering factors efficiency and affordability. The product includes the necessary biometric sensors as stated by several studies that are required for early detection of illness. So with right algorithm the device can be programmed in future, for early detection of illness. Audio recognition technology can be employed in the watch for dispensing the sanitizer in future.

REFERENCES

- [1] Darcy W. Greep "Wearable Hand Sanitation Devices" (2005)
<https://patents.google.com/patent/US20060078484A1>
- [2] Xiao Li, Dunn, J., Salins, D., Zhou, G., Zhou, W., Schüssler-Fiorenza Rose, S. M., Perelman, D., Colbert, E., Runge, R., Rego, S., Sonecha, R., Datta, S., McLaughlin, T., Snyder, M. P Digital Health: Tracking Physiomes and Activity Using Wearable Biosensors Reveals Useful Health-Related Information (2017)
<https://journals.plos.org/plosbiology/article?id=10.1371/journal.pbio.2001402>
- [3] Michael P. Snyder's team and collaborators "Stanford Medicine scientists hope to use data from wearable devices to predict illness, including COVID-19."
<https://med.stanford.edu/news/all-news/2020/04/wearable-devices-for-predicting-illness-.html>



Manasi Chaudhari

Electronics and Telecommunication Engineer



Shwetambari Thakare

Electronics and Telecommunication Engineer

BIOGRAPHIES

Yash Gangwal

Mechanical Engineer



C. Sai Manish Reddy

Mechanical Engineer



Gauri Wadyalkar

Electronics and Telecommunication Engineer



Santhiya E

Electronics and Communication Engineer



Fahima Jafreen.A

Electronics and Communication Engineer



Pushkar Shekhar Tambe

Information Technology