

# Seismic Analysis of an Irregular RC Building with and without Masonry Infill

Ammar Ahmed Khan<sup>1</sup>, Astha Bansal<sup>2</sup>, Aviral Agrawal<sup>3</sup>

<sup>1,2,3</sup>Student, Dept. of Civil Engineering, Delhi Technological University, Delhi, India

\*\*\*

**Abstract**— In the last few decades, through development of computer technology in civil engineering so many different seismic analyses became possible and accuracy of the analysis has vastly increased. Therefore there are lots of methods for seismic assessment and analysis in use. Including the probabilistic approaches into the seismic assessment offer more realistic approaches. Recently, seismic assessments are done with this consideration. Due to the advent of creative software in the design field, it has now become possible to model masonry infill in a structure. Earlier, instead of modelling masonry infill the loads were manually calculated and were employed to the structure. This method did not include the additional stiffness due to the infills. This paper presents a review of the seismic analysis and application of infills on a mass regular and mass irregular building and further withdrawing conclusions.

## Keywords—

**M1 : G+3 Bare frame.**

**M2 : G+3 with infill**

**M3 : G+3 Bare frame with irregularity**

**M4 : G+3 with infill with irregularity**

**M5 : G+6 Bare frame.**

**M6 : G+6 with infill**

**M7 : G+6 Bare frame with irregularity**

**M8 : G+6 with infill with irregularity**

**M9 : G+9 Bare frame.**

**M10 : G+9 with infill**

**M11 : G+9 Bare frame with irregularity**

**M12 : G+9 with infill with irregularity**

**RSA : Response spectrum analysis**

**SA : Static Analysis**

## 1. INTRODUCTION

Seismic risk analysis has become important as it provides an insight into the vulnerability of the structure to the seismic forces. If we know the seismic risk for a building we can permit for a well defined monetary plan, aid with the evaluation and locating or re-allocating of the required

labour for the reduction and to manage disaster actions, enlight the professionals and public on reducing hazard effects, calculate loss and damage estimations, and make appropriate decisions whenever needed. The components that define risk in seismic analysis and loss calculations are:

1. Analysis of Hazard
2. Effect of local site
3. Vulnerability Analysis

For the Hazard, analysis is the procedure that consists of estimating the ground vibration at a region or a site. This analysis gives a curve depicting the exceedance probability for different ground vibration at a region, or a map that displays the calculated magnitude distribution of ground vibration having a particular exceedance probability over a given time period.

Through an earthquake, the failure of structure starts at weak points of a structure. This weakness springs because of an irregularity in the structure which can be either vertical irregularity or plan irregularity. The buildings that have a discontinuity are called as Irregular buildings. Irregular buildings comprise a vast area of urban infrastructure. One of the major reasons for the failure of a structure during earthquakes is vertical irregularity. For example, the buildings having a soft story were seen to collapse more than the other type of structures having different irregularity. Therefore, the vertical irregularities play a major role in seismic analysis and in the performance of a building.

The Time history analysis is the response of the building including inertial effects, this is advanced to response spectrum analysis, and gives **base acceleration, displacement, and duration**. This is useful for very high rise structures to know the behaviour of structure under any seismic attacks. This analysis requires previous earthquake data to perform the analysis. It is a process of the response of a building under specific load that may or may not change with time. E tabs configures the start condition of a function in a different way for linear and nonlinear time-history loads. An explanation is given as:

- The **Linear cases** initiate from 0, hence the correlating time function must also start from nil.
- The **Nonlinear cases** can initiate from 0 or it may start from a preceding case. When it starts from 0, the corresponding time function is made to begin with a 0 value. When analysis from a preceding case is done, the time function continues relative to its

initial value. A large data may be divided into multiple analyses which use the same function. This avoids the requisition to make many functions.

**Fast Nonlinear Analysis** which is also known as FNA is an analysis technique which is useful for determination of a static and dynamic behaviour of linear and nonlinear structures. Because of its high efficiency & fast calculation, FNA is appropriate for this analysis, and it is mostly suggested for direct-integration techniques. During dynamic-nonlinear Fast Nonlinear Analysis, the configured models:-

- Should be linear elastic.
- Should have a limited no. of defined nonlinear structural members.

### El Centro

The **El Centro earthquake** or the **1940 Imperial Valley earthquake** originated on May 18 in the Imperial Valley in southeastern Southern California near the international border of the United States and Mexico.

The El centro earthquake was identified as a moderate disastrous event. It caused major destruction and the deaths of nine people.

### 2. ANALYTICAL STUDY

In the present study we have taken 12 different models configurations of building that are as mentioned in keywords. To introduce Mass irregularity a load of 3 kN/m<sup>2</sup> is added on each third floor.

Along with the above twelve models mitigation techniques like introduction of infill walls frames are used and frames are analysed.

The buildings have been modelled & simulated using ETABS 2018, according to the standard IS 1893(Part 1): 2016, Criteria for design of Earthquake resistant structures.

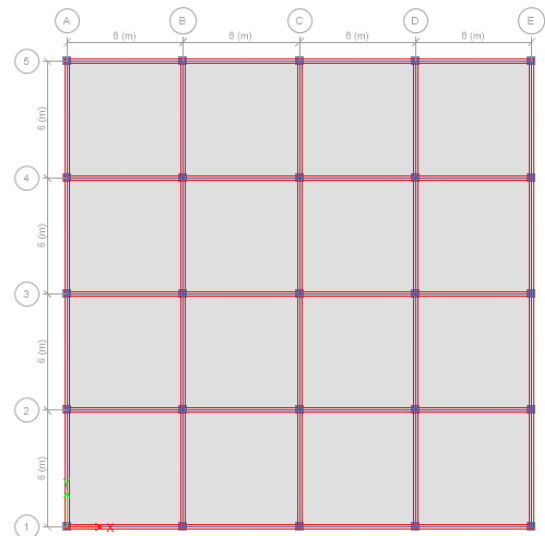

**Fig. 1** Plan of the structure considered in the study.

### 3. DETAILS OF BUILDING AND MODELLING OF STRUCTURE

#### GEOMETRICAL PROPERTIES:

- Concrete with grade and modulus of elasticity as M25 & 25000 N/mm<sup>2</sup> respectively.
- Beam Dimensions: 300mm x 600mm.
- Column dimensions: 450mm x 450mm.
- Slab thickness: 150 mm.
- Poisson's ratio is 0.2.
- The yield stress of reinforcements is 500 MPa.
- Foundation in all the models is assumed to be a fixed support system.
- Wall thickness is 230 mm
- Unit weight of Masonry walls 21.2068 kN/m<sup>3</sup>
- Floor height : 3.3m
- Plan size: 24m x 24m
- No.of bays along X-direction: 4
- No.of bays along Z-direction: 4

**4. SEISMIC PARAMETERS AND LOAD**

- IS 1893 (Part 1): 2016 is used for the consideration of seismic parameters and of static analysis of all the configurations
- All buildings were assumed to be in zone IV..
- For all models Importance Factor (I) is considered as 1.
- For all models Response reduction factor (R) is considered as 5..
- The soil is assumed to be medium soil.
- IS 875 (Part 1 and 2): 1987 is used for gravity and imposed loads.
- Imposed load is taken be 3 kN/m<sup>2</sup>
- For irregularity additional load of 3 kN/m<sup>2</sup> is added at every third floor.

**5. MODELS ANALYSED**

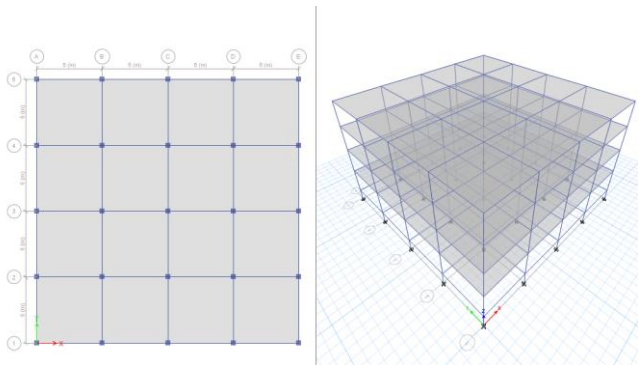

**Fig. 2** M1-plan and 3D view

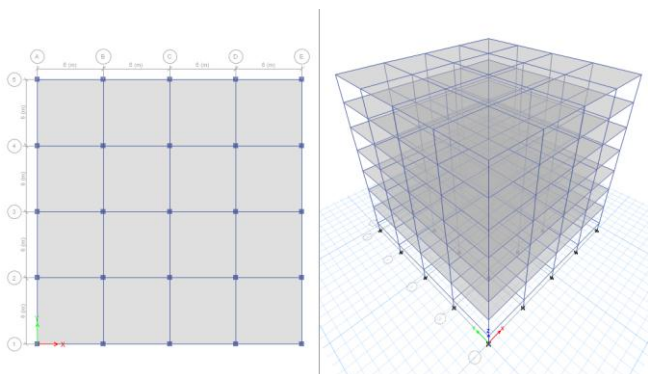

**Fig. 3** M5-plan and 3D view

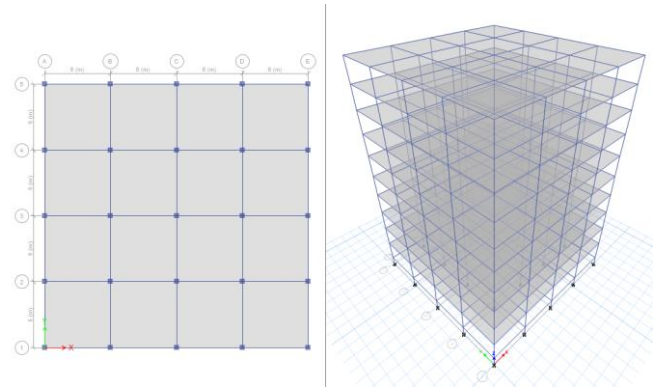

**Fig. 4** M9-plan and 3D view

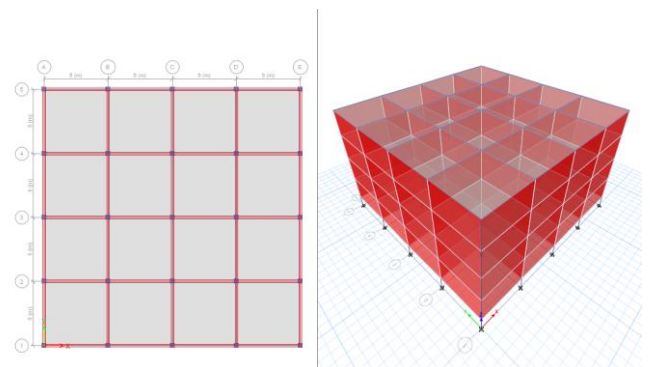

**Fig. 5** M2-plan and 3D view

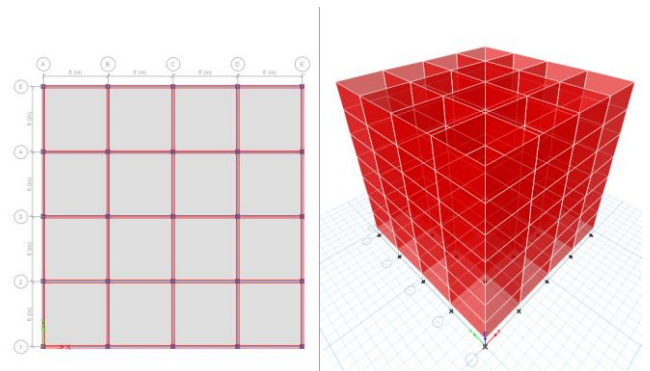

**Fig. 6** M6-plan and 3D view

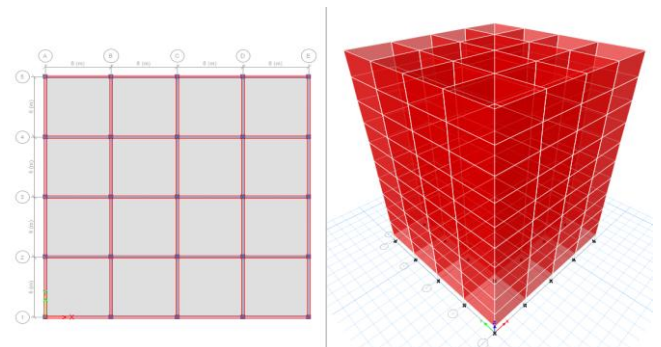

**Fig. 7** M10-plan and 3D view

## 6. RESULTS AND DISCUSSIONS

The twelve models were used to draw comparison between each other based on:

- Response spectrum (linear dynamic method)
- Time history (Nonlinear dynamic method)

## 7. RESPONSE SPECTRUM ANALYSIS

### A. COMPARISON OF G+3 FRAMES

Frame	Base Shear (kN)	Time period (s)	Max displacement (mm)	Drift (unitless)
M1-SA	2061.48	0.563	23.931	0.002079
M1-RSA	2067.01	0.563	24.065	0.002089
M2-SA	2122.47	0.563	0.442	0.00026
M2-RSA	2122.47	0.563	0.442	0.00066
M3-SA	2086.52	0.563	24.202	0.002107
M3-RSA	2086.52	0.563	24.002	0.002107
M4-SA	2147.52	0.563	0.447	0.000263
M4-RSA	2147.52	0.563	0.447	0.000263

### B. COMPARISON OF G+6 FRAMES

Frame	Base shear (kN)	Time period (s)	Max displacement (mm)	Drift (unitless)
M5-SA	3437.29	0.821	66.216	0.003516
M5-RSA	3437.29	0.821	66.216	0.003516
M6-SA	3669.26	0.821	0.901	0.000428
M6-RSA	3669.26	0.821	0.901	0.000428
M7-SA	3487.38	0.821	67.120	0.003567
M7-RSA	3487.38	0.821	67.121	0.003567
M8-SA	3719.95	0.821	0.913	0.000434
M8-RSA	3719.35	0.821	0.914	0.000434

### C. COMPARISON OF G+9 FRAMES

Frame	Base shear (kN)	Time period (s)	Max displacement (mm)	Drift (unitless)
M9-SA	4813.11	1.061	132.455	0.004939
M9-RSA	4813.11	1.061	132.455	0.004939
M10-SA	5031.87	1.061	1.594	0.000581
M10-RSA	5031.88	1.061	1.595	0.000581
M11-SA	4888.24	1.061	134.432	0.005014
M11-RSA	4888.24	1.061	134.432	0.005014
M12-SA	5291.18	1.061	1.665	0.000611
M12-RSA	5291.19	1.061	1.666	0.000611

### D. MAXIMUM STOREY DISPLACEMENT

FLOOR LEVEL	M1	M3	M2	M4
BASE	0	0	0	0
PB	1.027	1.04	0.39	0.3947
FF	7.753	7.848	0.403	0.407811
SF	14.613	14.8	0.416	0.420926
TF	20.347	20.613	0.429	0.43402
Terrace	23.931	24.202	0.4418	0.447053

FLOOR LEVEL	M5	M7	M6	M8
BASE	0	0	0	0
PB	1.636	1.66	0.641	0.65
FF	12.439	12.616	0.678	0.687
SF	24.043	24.388	0.715	0.725
TF	35.311	35.82	0.753	0.763
IVF	45.737	46.38	0.79	0.8
VF	54.818	55.592	0.827	0.838
VIF	61.84	62.772	0.864	0.875
Terrace	66.216	67.12	0.901	0.913

### E. BASE SHEAR

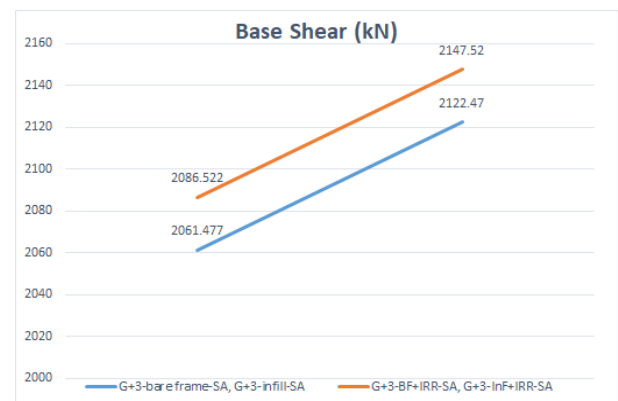

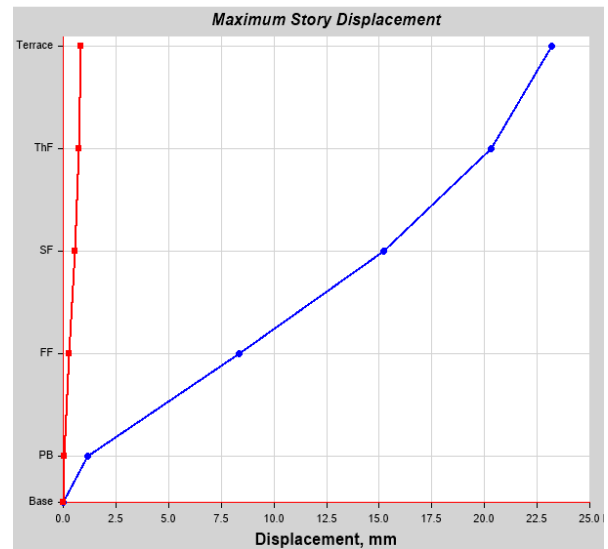
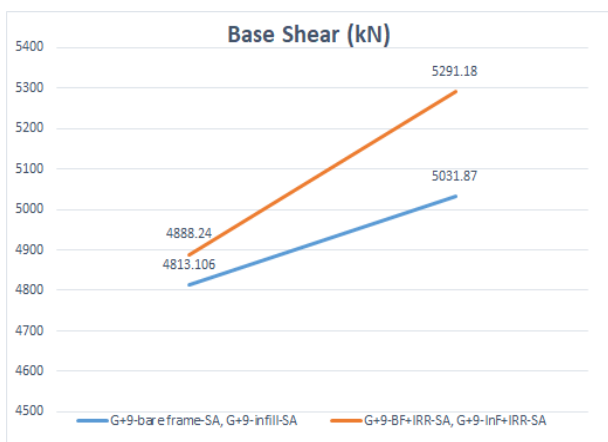
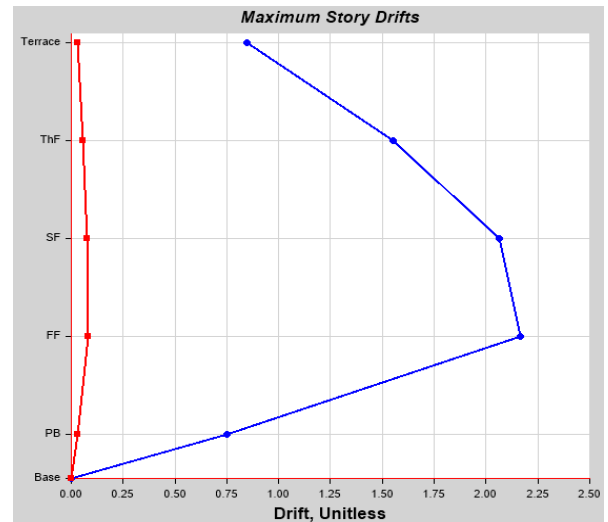
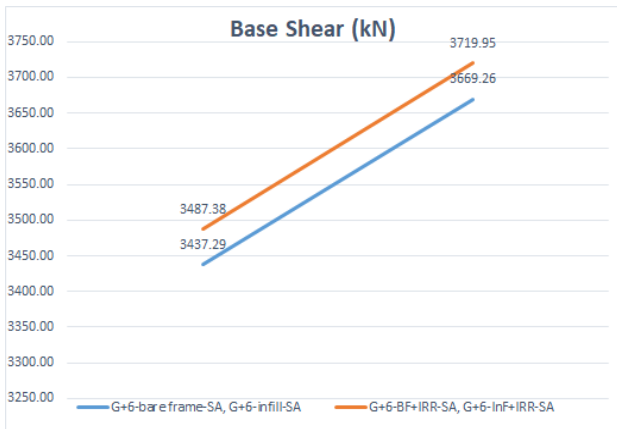

## 2) TIME HISTORY ANALYSIS

### A. M1

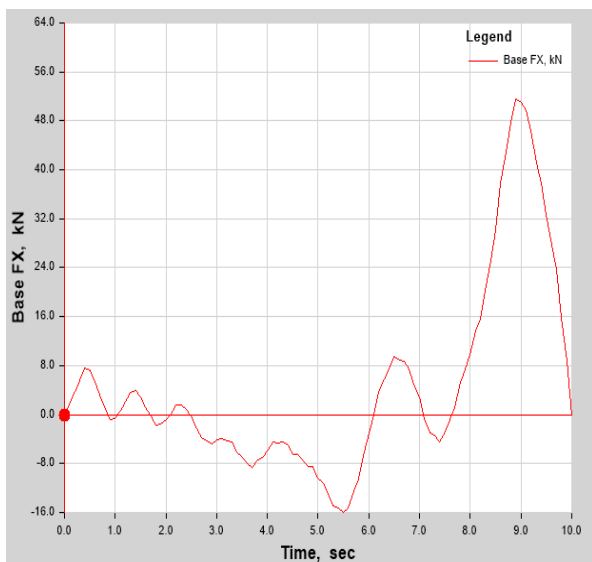

### B. M2

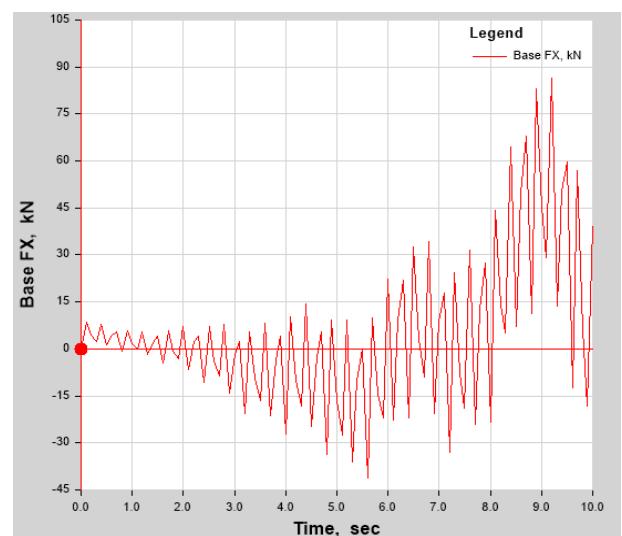

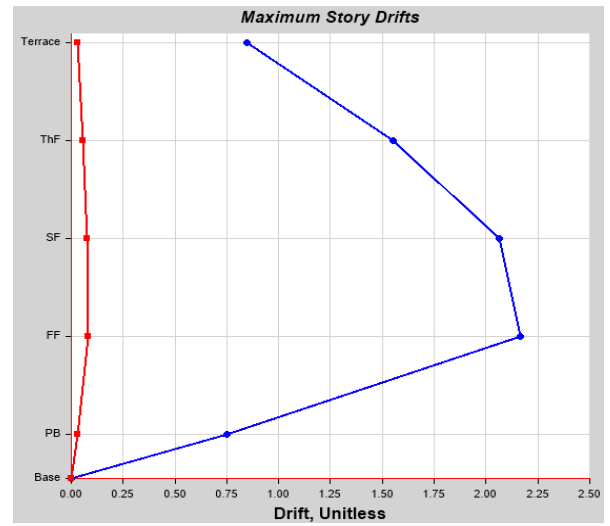
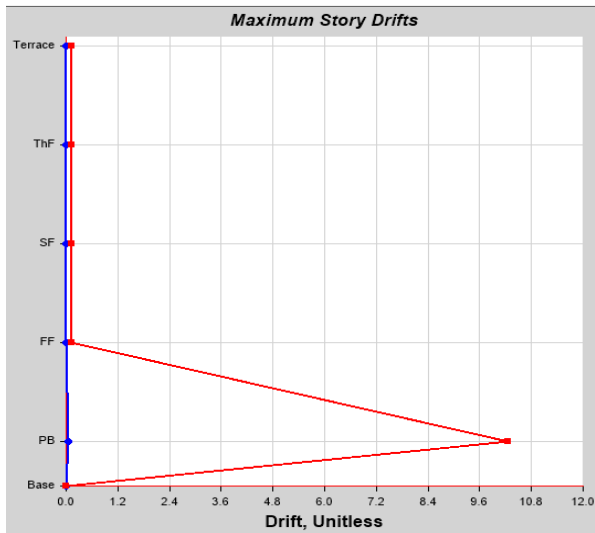
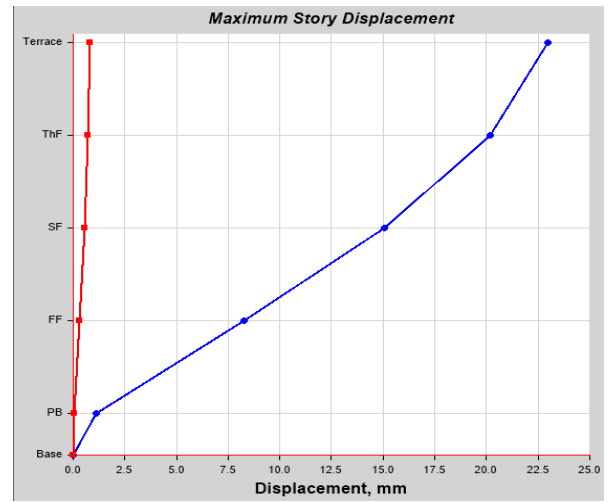
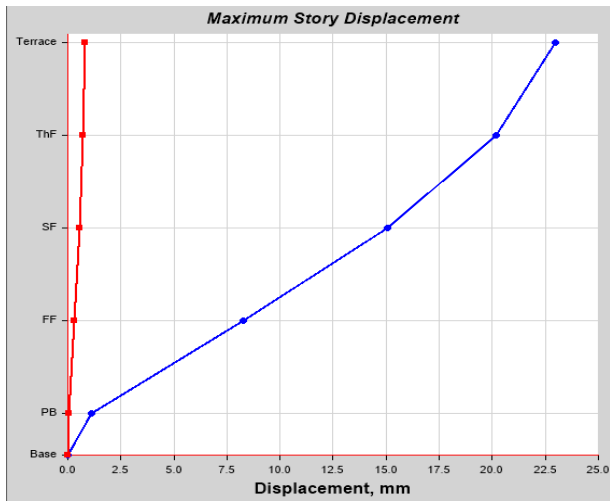

C. M3

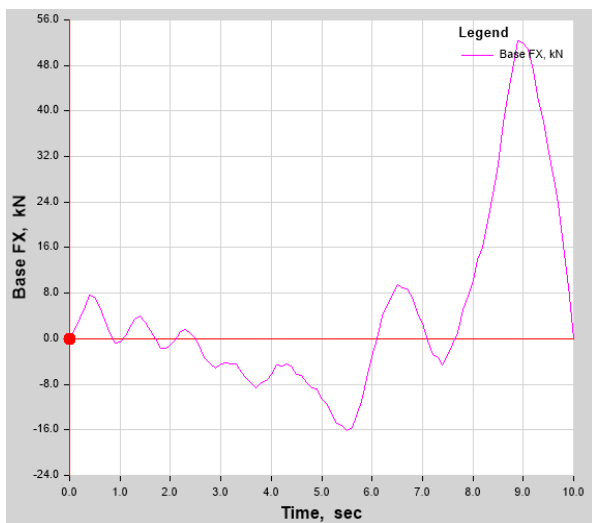

D. M4

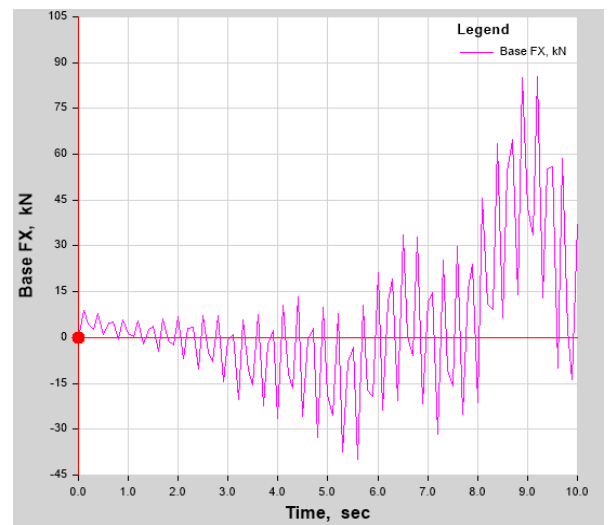

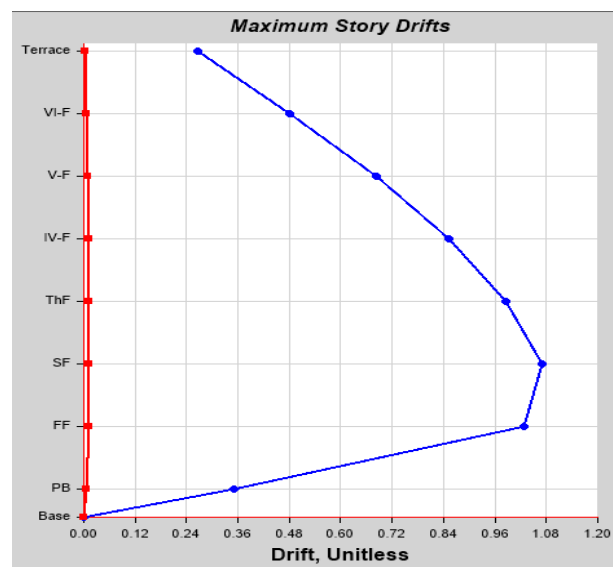
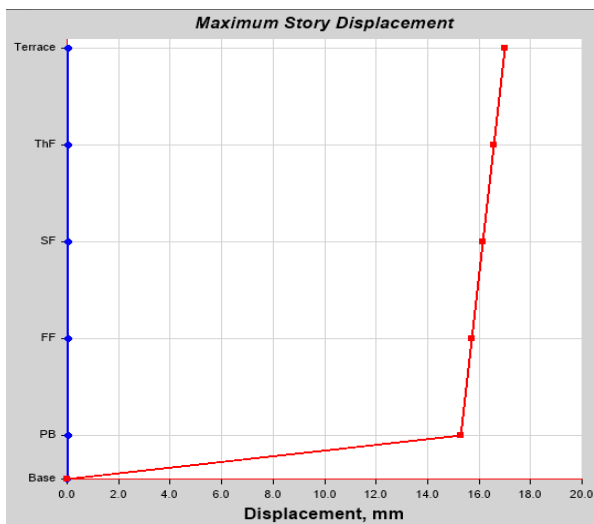
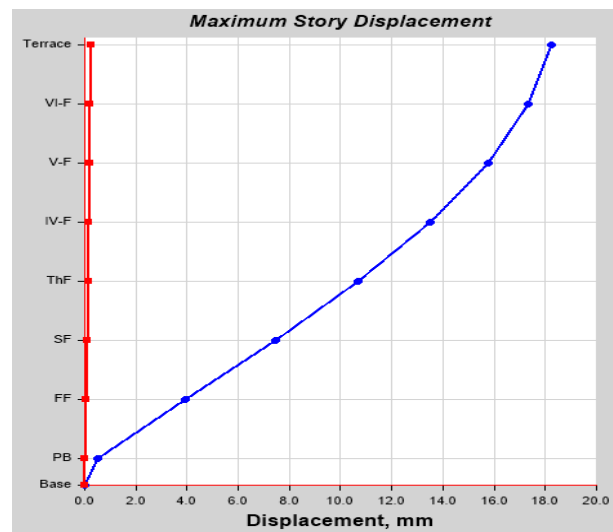
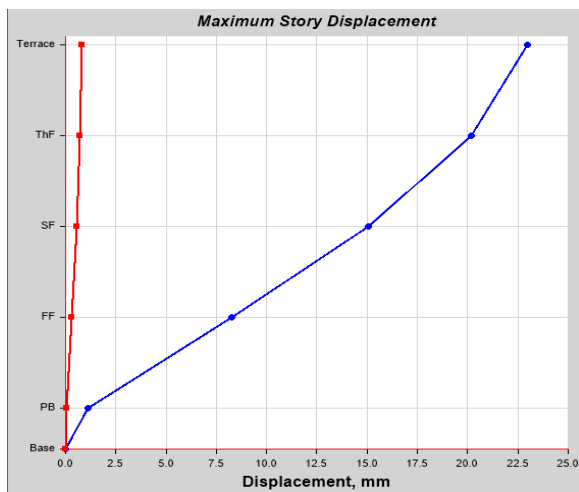

E. M5

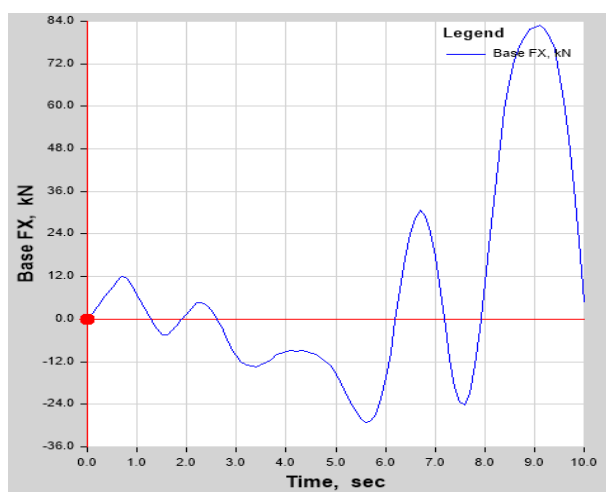

F.M6

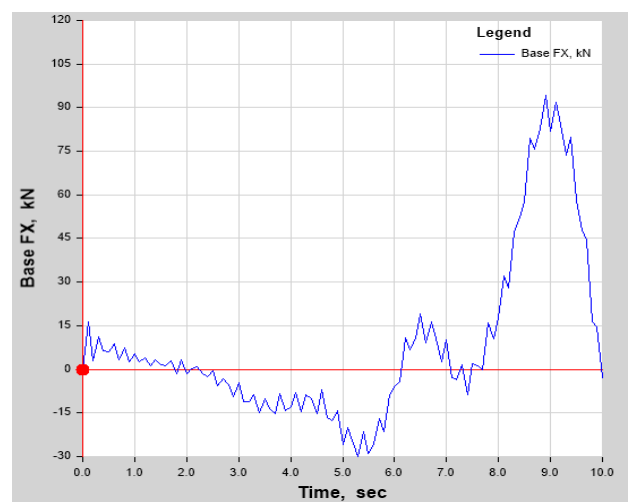

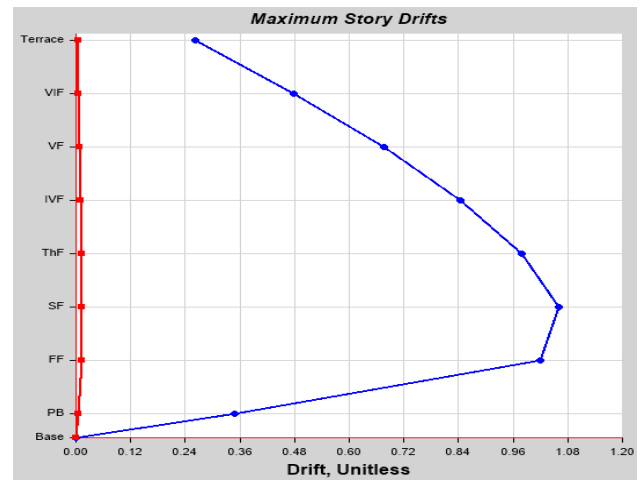
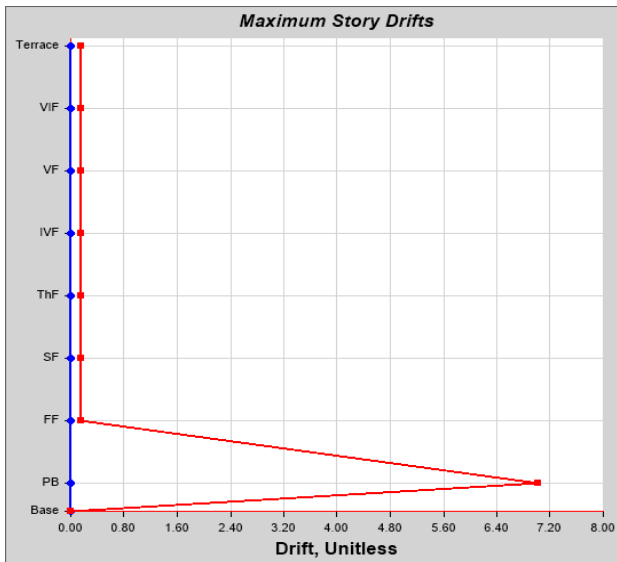
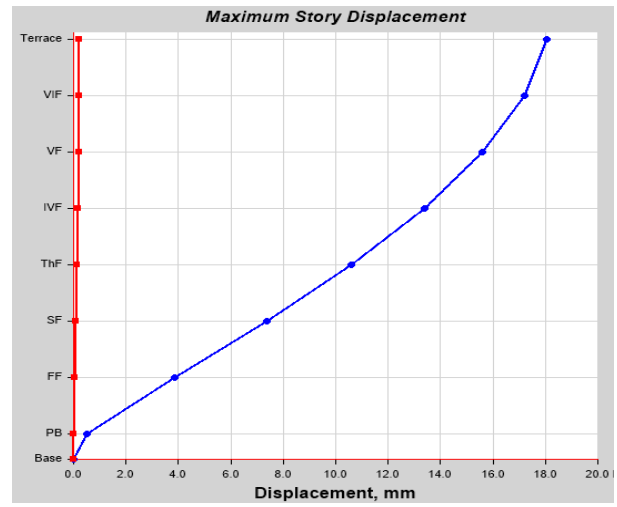
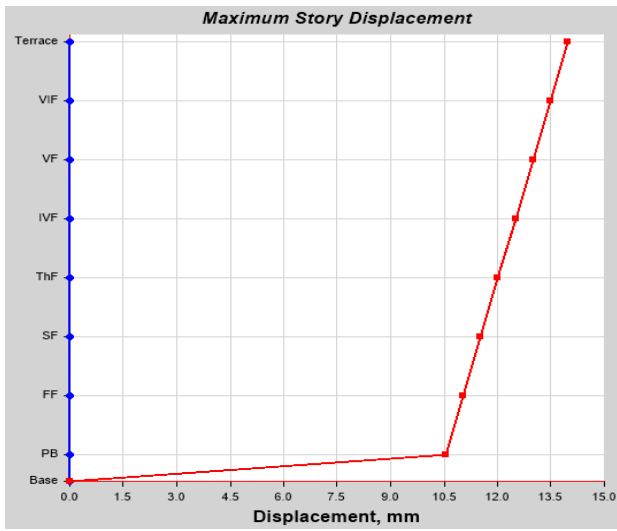

H. M8

G. M7

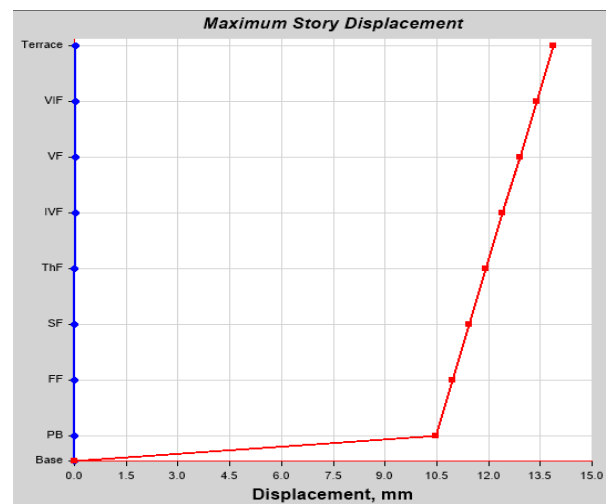
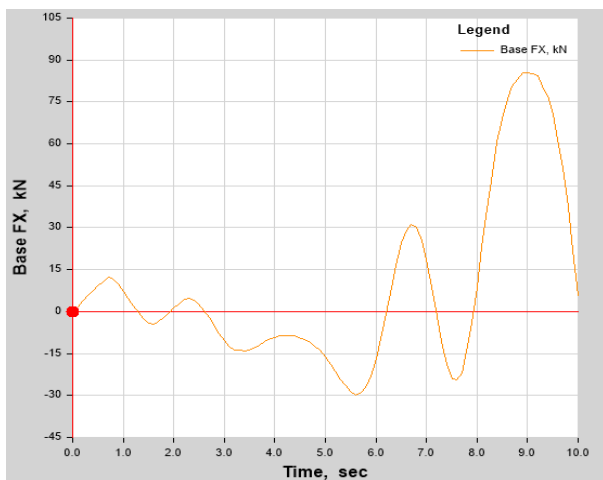



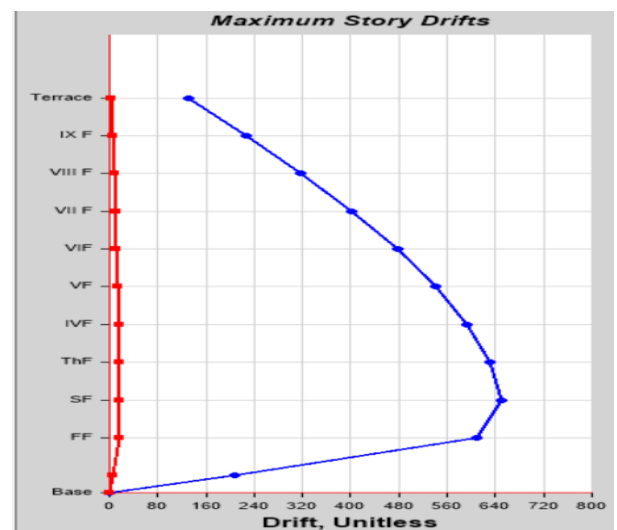
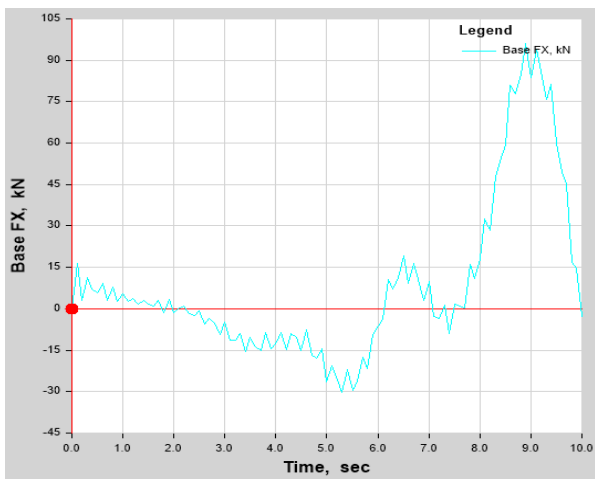
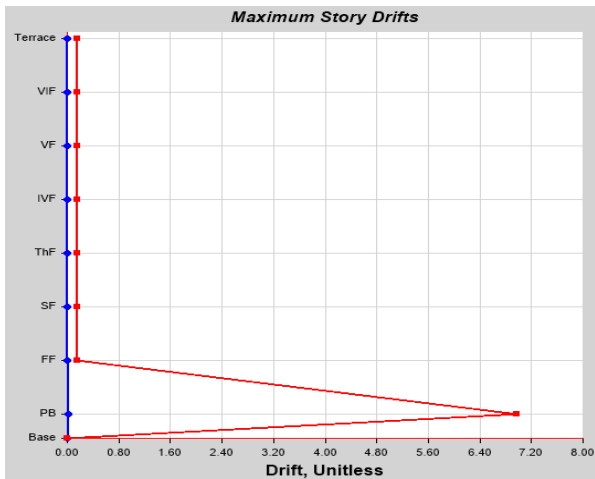

I. M9

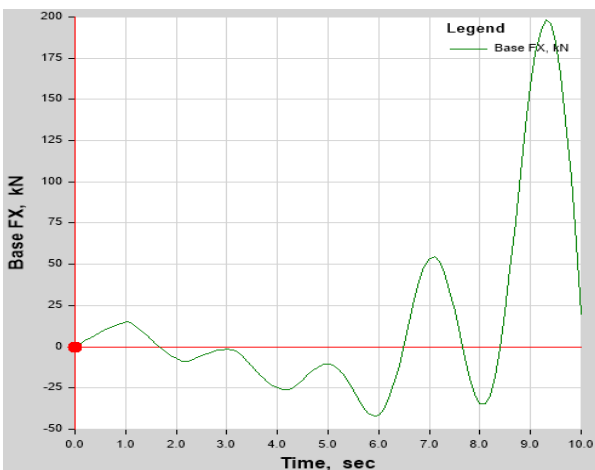

J. M10

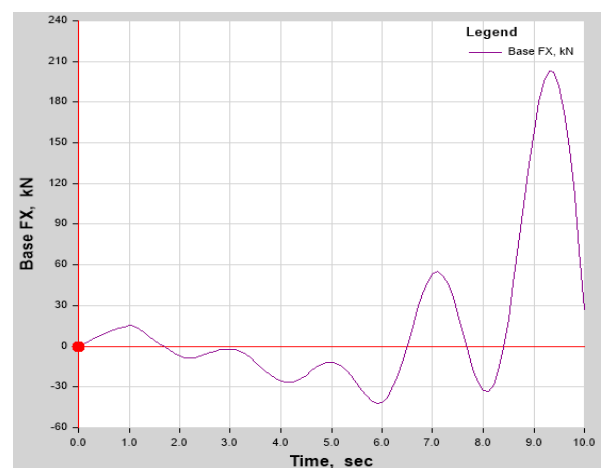

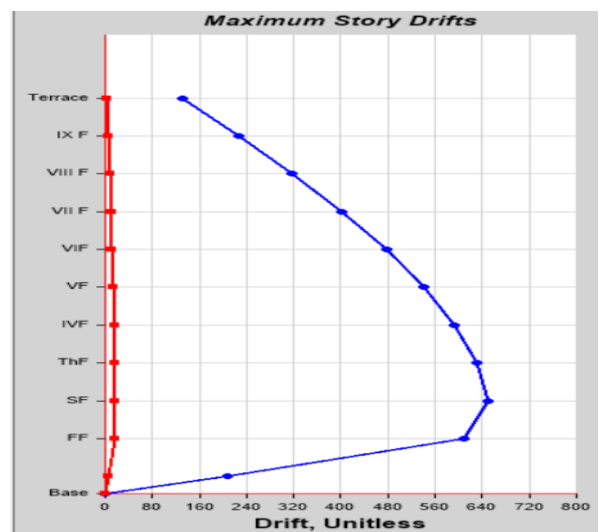
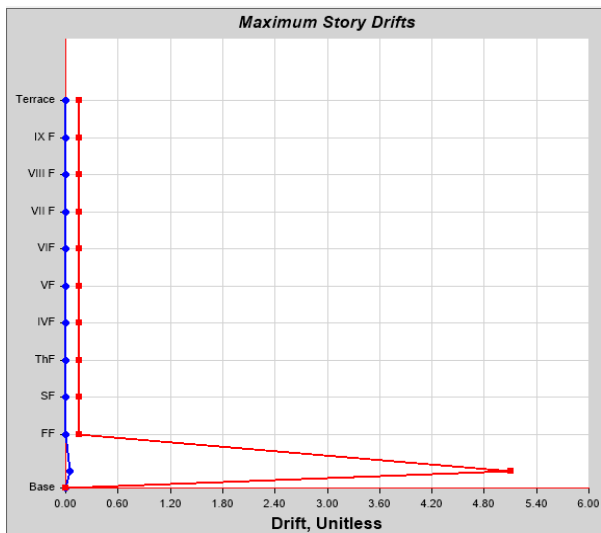
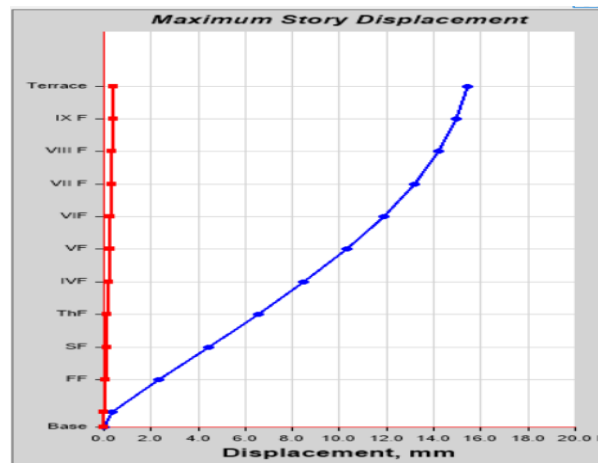

K. M11

L. M12

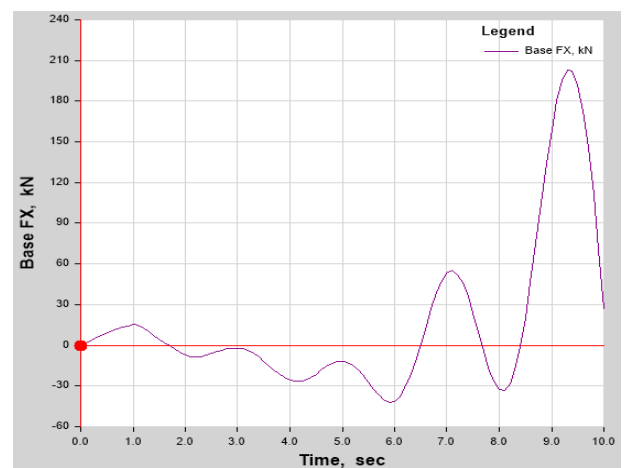
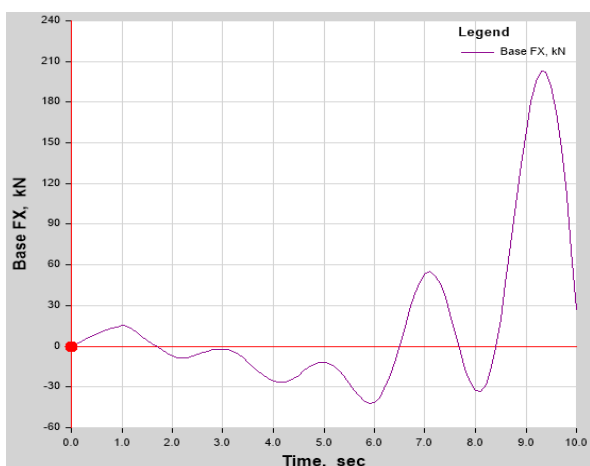

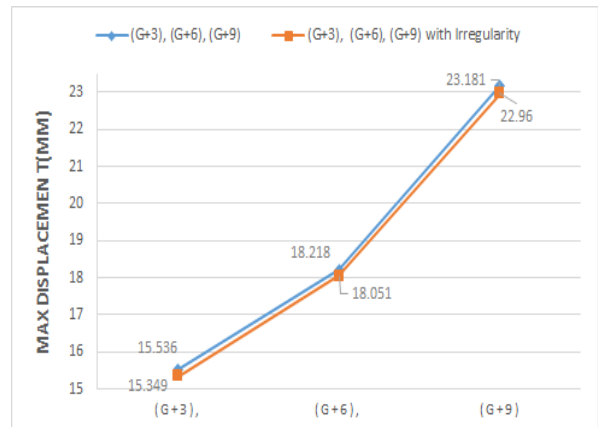
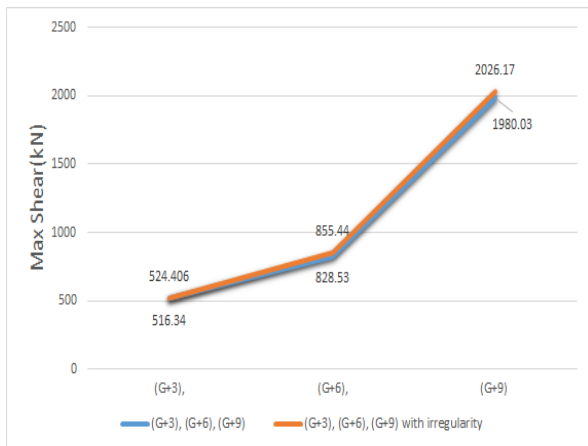
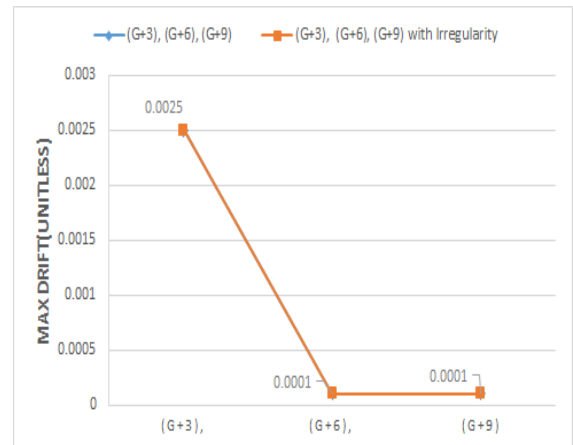
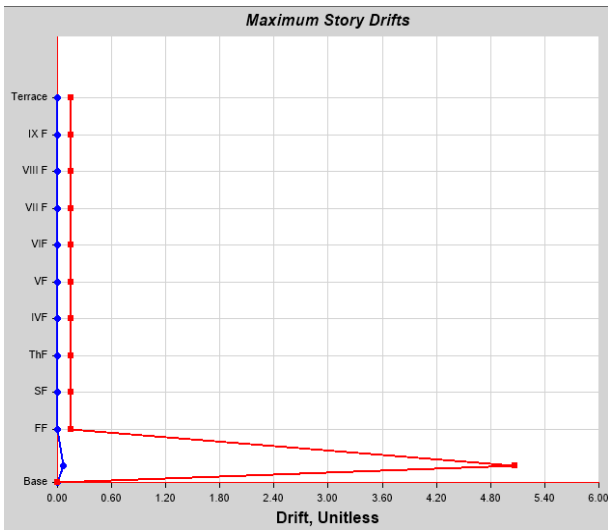
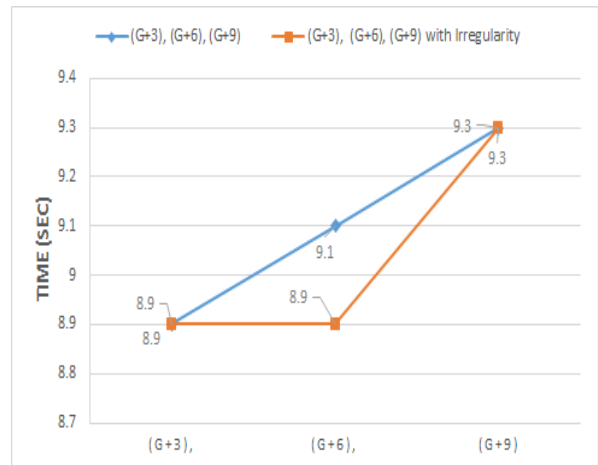
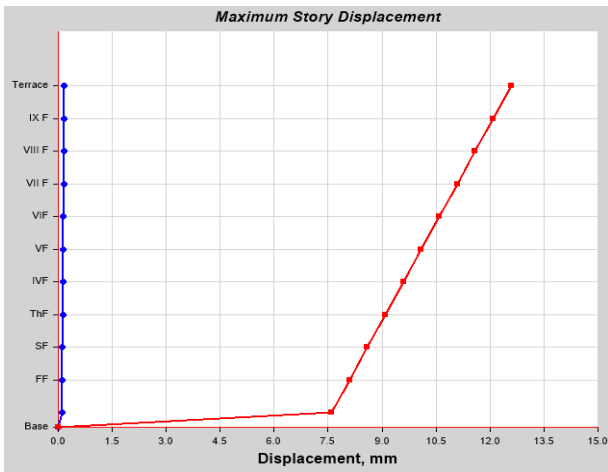

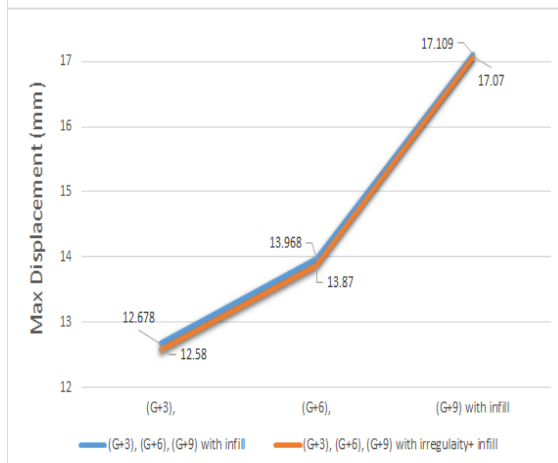
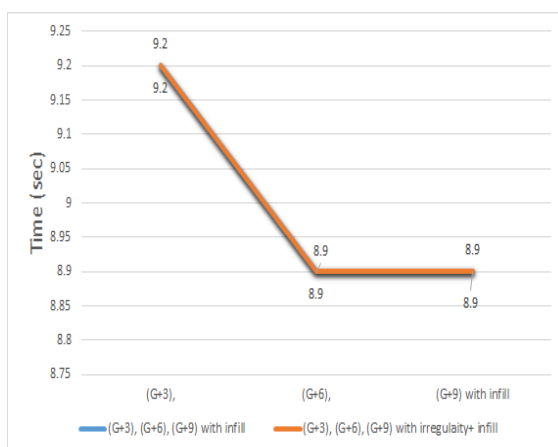
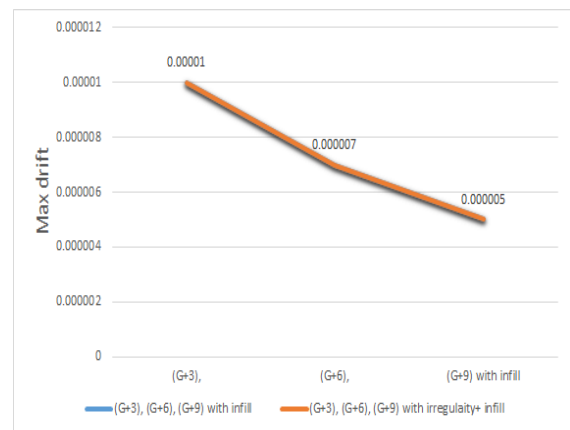
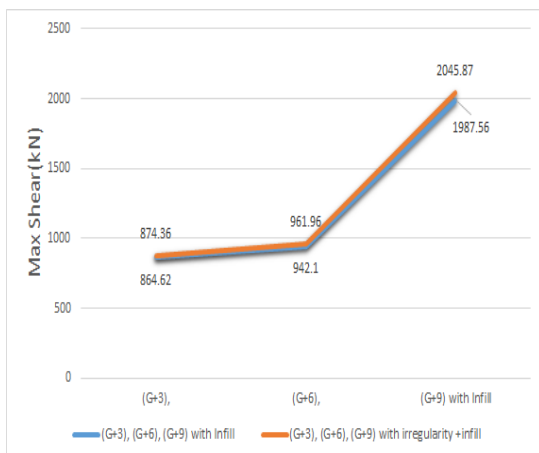

## 7. CONCLUSION

### Response Spectrum Analysis

- Including infill in the structure increases the inter storey stiffness which decreases the max displacement upto **2%** of the initial value.
- The magnitude of base shear increases when we include masonry infill when compared to without masonry infill for about **(3 - 8) %** of the initial value.

Due to inclusion of mass irregularity the Max displacement has been increased from **(1.2 - 1.8) %** of the initial value.

- The magnitude of base shear increases due to mass irregularity to about **(0.8 - 1.2) %** of the initial value.
- Including infill in the structure increases the inter storey stiffness which decreases the max displacement by **98%** as compared to bare frame.
- The magnitude of base shear increases with the introduction of masonry infill when compared to without masonry infill for about **(3 - 8) %** with comparison to bare frame .
- Due to inclusion of mass irregularity the Max displacement has been increased from **(1.2 - 1.8) %** of the initial value.
- The magnitude of base shear increases due to mass irregularity to about **(0.8 - 1.2) %** of the initial value.
- Time period decreases on the inclusion of the masonry infill

### Time History Analysis

- It is noted from the results that the Base shear is increased by about :-

- **2.38 %** in mass irregular buildings when compared to the regular building.
- **2.056%** in mass irregular building with infill when compared to the regular building with infill.
- **27.17%** in regular buildings with infill when compared to the regular building without infill.
- **26.18%** in mass irregular building with infill when compared to the mass irregular building without infill.
- Further it is observed that the Max displacement is reduced by about :
  - **1.024%** in mass irregular buildings compared to regular buildings.
  - **0.56%** in mass irregular buildings with infill when compared to regular buildings with infill.
  - **22.63%** in regular building with infill when compared to regular bare frame building
  - **22.28%** in irregular buildings with infill when compared to irregular buildings without infill.

#### **Effect of masonry infill :**

- Increase in lateral stiffness in comparison to the bare frame
- Decrease in time period in comparison to the bare frame
- Decrease in maximum displacement as compared to the bare frame

#### **8. REFERENCES**

- [1] NATARAJAN, S., & VEERARAGAVAN, S. (2016). A Review on Analysis Design of Shear Walls in High Rise Irregular Building, 5(5), 0808-0815.
- [2] IS 456-2000-Design of RC structures
- [3] IS 1893-2016- Criteria for Earthquake Resistant Design of Structures
- [4] Sarkar, P., Prasad, A. M., & Menon, D. (2010). Vertical geometric irregularity in stepped building frames. Engineering Structures, 32(8), 2175-2182.

[5] Sampath Nagod , Prof. A.J.Zende.(2017).Seismic analysis of multi storey RC building due to mass irregularity by Time history analysis,4(8), 2319-1163.

[6] T. Choudhury and H. B. Kaushik..(2019)Seismic Fragility of Reinforced Concrete Frames with Vertical Irregularities.

[7] S.K Duggal, second edition, "Earthquake resistant design of structures", Oxford University press 2013