

# Design & Analysis of Wound Rotor Induction Motor Drive using Slip Power Recovery Scheme with Inverter Control for ID Fan in Power Plant

Manish Kapse<sup>1</sup>, Pratik Ghutke<sup>2</sup>

<sup>1</sup>PG Student, Dept. of Electrical Engineering, TGPCET Nagpur, Maharashtra, India

<sup>2</sup>Asst. Professor, Dept. of Electrical Engineering, TGPCET Nagpur, Maharashtra, India

\*\*\*

**Abstract** - Induction motors are used as industrial drive and for various fans in power plant due to their rugged and simple construction as well as low cost. The speed control of WRIM is proficient by slip power recovery scheme consisting of inverter control, chopper control, and rotor resistance control techniques. This paper presents the enhancement in the performance characteristics and energy saving of WRIM drive by GTO inverter and buck-boost chopper based slip power recovery scheme (SPRS). The simulation model of a WRIM drive using GTO inverter and GTO based buck-boost chopper control has been established in the Simulink platform. The simulation result using inverter and chopper control have been analyzed. The power factor, efficiency and total harmonic distortion have been taken as parameter for analyzing the enhancement in the performance of the WRIM drive and also find the energy saving by the drive. The simulation result has shown that GTO based inverter chopper control SPRS has good power factor, efficiency, lower Total Harmonic Distortion and large amount of energy saving.

controlled induction motors, the ratings of the rotor side converter, inverter and transformer circuit in SPRD is intended to be smaller and less expensive as these apparatuses have to deal with the slip power only. Enormous literature is available for slip power recovery drives. Many Authors presented motor performance using slip recovery systems, analysis of transient state of Kramer drives, and proposed new slip recovery scheme for improved power factor. Krause et al. 1988 presented reference study of slip power recovery drive. Akpınar and Pillai, 1990 presented modeling and performance of slip power recovery scheme for induction motor. A new energy recovery scheme for variable speed double fed induction motor was presented in (Fan et al., 1990). Many authors recommended, harmonic analysis, commutation angle analysis and performance enhancement of slip power recovery drive.

## 1. INTRODUCTION

Induction motor drives with control of speed have enormous applications in the modern industrial set up. Near about or greater than 75% of the industrial load today in any country consists of induction motor drives. Slip ring induction motor drives have found great applications due to the availability of easiest speed control, slip power easily available from slip rings and possesses high starting torque. Slip power can be recovered from static converters instead of wasting power in the rotor resistance. High performance induction motor drive application requires high efficiency, low cost and simple control electric circuit for the complete speed range. At the present time, slip power recovery drives (SPRD), is widely used for the limited speed range applications such as large-capacity fan drives and pumps, ship-board variable speed/constant frequency system, variable-speed wind energy systems etc. A schematic diagram of a SPRD is shown in Figure 1. It consists of a slip ring induction motor, a diode bridge rectifier, a large filter inductor, a thyristor bridge inverter and a three-phase recovery transformer. A slip power recovery scheme drive transfer power that is normally dissipates in the rotor of an induction machine back to the ac mains supply to improve overall induction motor drive efficiency. In distinction with the stator-voltage-

## 2. PERFORMANCE ANALYSIS OF THE DRIVE

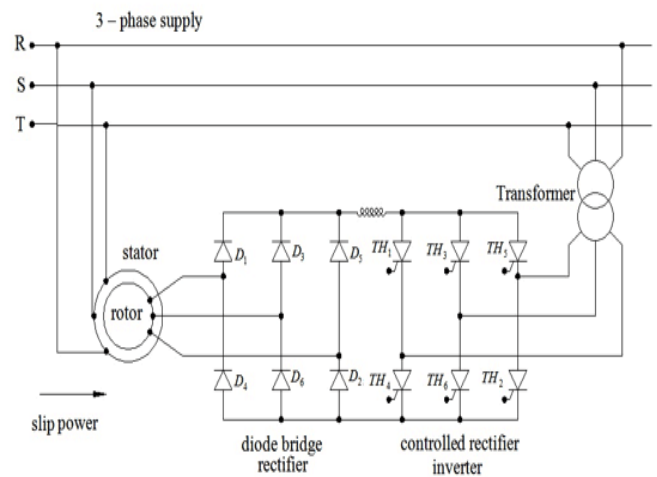

**Figure -1:** Diagram of Slip Power Recovery Drive (SPRD)

Assuming negligible rotor leakage reactance and ideal filtering ( $L_d = \infty$ ), the rotor currents are alternating square pulses of  $2\pi/3$  radians duration. The rms value of the rotor current  $I_2$  is  $\pi/3$  times the rms value of the fundamental component  $I_{2f}$  (Lavi et al. 1996). Ignoring the thyristors voltage drops, the average counter EMF,  $V_i$  of the inverter equals to

$$V_i = \frac{3\sqrt{6}}{\pi} \cdot \frac{V}{m} \cdot \cos \alpha \quad (1)$$

And converter voltage, Vr equals to

$$V_r = \frac{3\sqrt{6}}{\pi} \cdot \frac{sV}{n} \quad (2)$$

Where,  $\alpha$  is the firing angle of the inverter, V is the line-to-line source voltage, m is the source to converter side turn-ratio of the recovery transformer, s is the motor slip and n is the stator to rotor turns ratio of the motor. Since in steady state Vi and Vr must balance, therefore

$$s = \frac{n}{m} \cos \alpha \quad (3)$$

Thus, speed of the rotor can be controlled by changing inverter firing angle  $\alpha$ . The inverter recovers slip power from rotor of induction motor when  $\pi/2 < \alpha < \pi$  and can deliver energy to the rotor when  $\alpha < \pi/2$ .

The power equation for each rotor phase gives

$$E_{2f} I_{2f} = \left[ R_2 I_2^2 + \frac{1}{3} R_d I_d^2 \right] - \left[ \frac{1}{3} \left( 1.35 \frac{V}{m} \cos \alpha - V_{pec} \right) \times I_d + P_{mech} \right] \quad (4)$$

Here, Vpec is the voltage drop in the power electronics components, Id is the average dc current through filter inductor and Rd is the effective resistance of filter inductor. The aggregate mechanical torque produced by the rotor is the summation of torque produced by the fundamental component of rotor current and the torque produced by the rotor harmonic currents. Supposing that the torque is produced by the fundamental component of rotor current I2f only, the rotor mechanical power is given by

$$P_{mech} = \left[ (R_2 + 0.5R_d) I_{2f}^2 \frac{1-s}{s} \right] - \left[ \left( 1.35 \frac{V}{m} \cos \alpha - V_{pec} \right) \frac{I_d}{3} \frac{1-s}{s} \right] \quad (5)$$

Here, 0.5Rd is the filter inductor resistance referred to rotor side.

Slip power (power feedback), sPg is given by

$$sP_g = V_i I_d = 1.35 \frac{V}{m} \cos \alpha I_d \quad (6)$$

$$P_{mech} = (1-s)P_g = T_e \omega_r = T_e \omega_s (1-s) \frac{2}{P} \quad (7)$$

The rotor electromagnetic torque is given by,

$$T_e = \left( \frac{P}{2} \right) \frac{P_g}{\omega_s} \quad (8)$$

From equations (3), (6), (7) and (8), the torque is calculated as:

$$T_e = \left( \frac{P}{2} \right) \frac{1.35V}{\omega_s n} I_d \quad (9)$$

Hence, torque is proportional to inductor current Id. This current depends upon the difference between Vi and Vr. So, for a fixed value of, the torque-slip characteristics of the drive is almost linear and look like to the separately excited dc motor. The power flow diagram of the induction motor with SPRD has been shown in Figure 2.

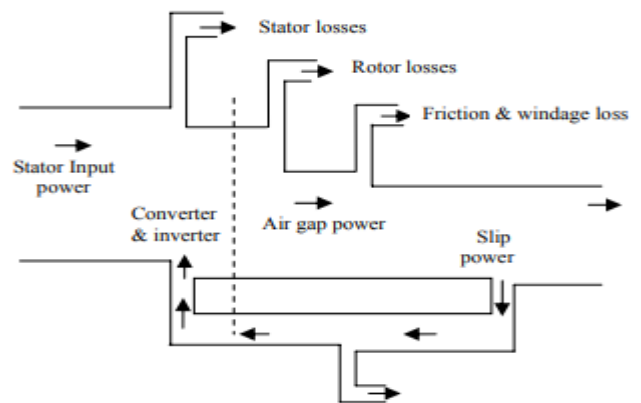

Figure -2: Power flow diagram of the SPRD

To study the performance of the drive, a simulation block-set in Matlab/Simulink has been implemented. A 4 hp, 400 V, 50 Hz slip ring induction motor has been used for the simulation. Provision has been made to measure stator current, speed and torque of the motor. The active power and reactive power input of the slip ring induction motor, the recovery transformer and the source have been measured using P-Q block. Provision has also been made to measure different currents and voltages of the scheme wherever required.

### 3. CONCLUSIONS

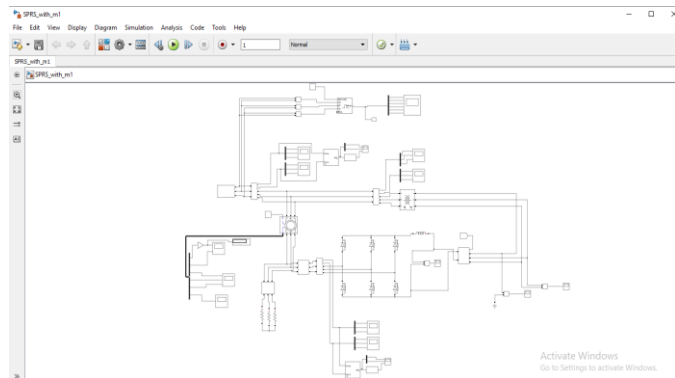
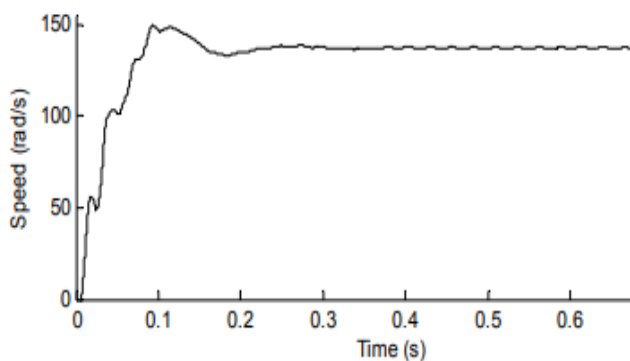

Figure -3: Matlab simulation of SPRD

Simulation results illustrate that by changing firing angle (above 90 degree) in small intervals, motor speed can be controlled from zero to nominal speed. The motor speed vs. time characteristics at two different firing angles have been shown in Figure 4. It can be detected that steady state speed for higher firing angle is less as compared to lower firing angle. The higher value of firing angle is limited to 165° for the safe commutation of thyristors.



(a)

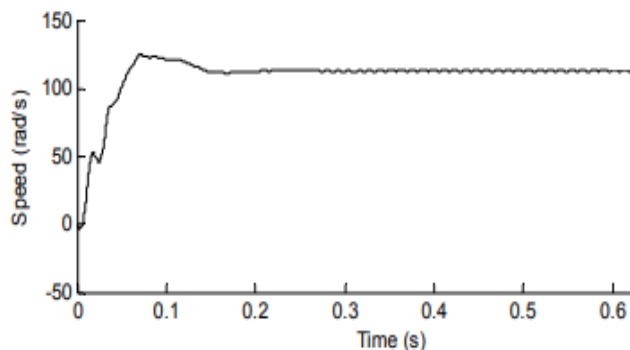

Figure -4: Motor speed at (a) 92 degree (b) 100 degree firing angle

Figure -5 shows active power, reactive power and power factor of recovered power. This means that active power is

pay back to the network but a large amount of reactive power is absorbed from the source. Because of this reactive power consumption, the overall power factor of the scheme becomes low, which can be shown from the power factor curve.

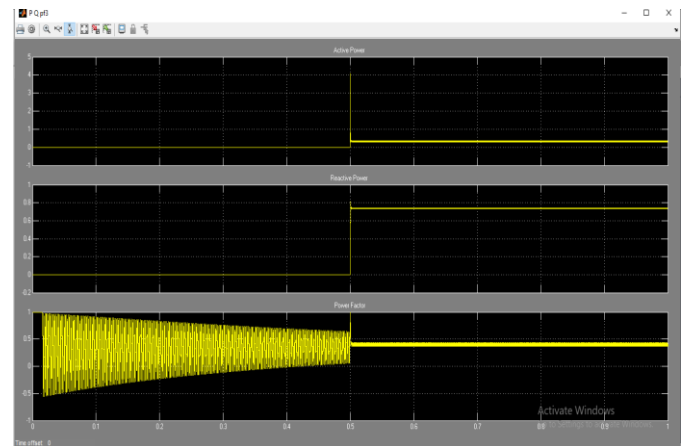

Figure -5: Recovered Active, Reactive power and power factor

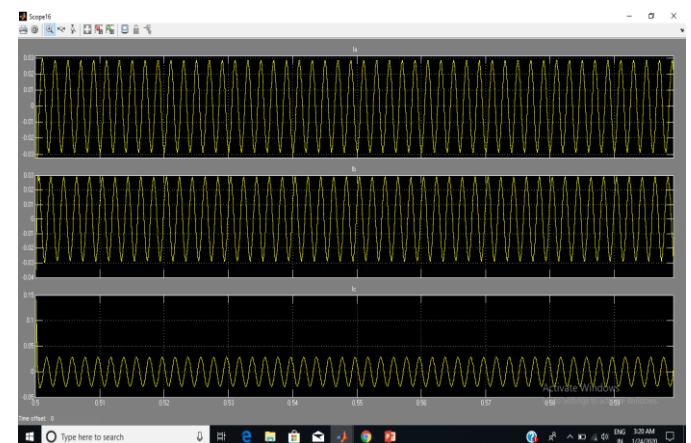

Figure -6: Feedback current

Figure -6 shows output current (feedback current) of all the three phases a, b, c.

The slip recovery energy method for the speed control of three-phase wound rotor induction motor has been examined. The performance equations have been drawn and a simulation block-set model in Matlab/Simulink has been implemented.

### REFERENCES

[1] Leonharn, W., 1985. Control of Electric Drives., Springer Verlag, Berlin.  
 [2] Krishnan, R., 2001. Electric Motor Drives, Modeling and Analysis. Prentice Hall, Inc.

[3] Stiebler, M., 2010. Doubly-fed asynchronous machine for low voltage drives. *Electrical Machines*, 2010 XIX International Conference on Electrical Machines, Vol. 1, No.6, pp.6-8.

[4] J.E. Brown, W. Drury, B.L. Jones and P. Vas, "Performance and Analysis of the Static Scherbius Drive," *Proc IEEE*, Vol 133, Pt.B, No. 1, Jan 1986, pp 21-30.

[5] Akpınar E, Pillay P. "Modeling and analysis of slip energy recovery induction motor drive". *IEEE Trans Energy Conversion* 1990; 5(1):203-10. [29]

[6] Akpınar E, Pillay P. "Starting transients in slip energy recovery induction motor drives-part-2: performance and flowchart". *IEEE Trans Energy Convers* 1992; 7(1):245-51.

[7] Liao F, Sheng JI, Thomas AL. "A new power recovery scheme for doubly fed, adjustable-speed induction motor drives". *IEEE Trans Ind Appl* 1991; 27(4):728-33.