

# Validation of Biofuel as an Alternative for Diesel and Thermal Analysis of Engine Components

Priyanka Jadhav<sup>1</sup>, Pravin Jadhav<sup>2</sup>, Shubham Garde<sup>3</sup>, Raturaj Mane<sup>4</sup>

<sup>1</sup>Rajarambapu Institute of Technology, Rajaramnagar, Sangli, Maharashtra, India.

<sup>2,3,4</sup>JSPM's Rajarshi Shahu college of engineering, Tathawade, Pune, Maharashtra, India.

\*\*\*

**Abstract-** Rapid industrialization and growth in population has resulted in the rapid increase in energy demand. Indiscriminate use has led to extinction of petroleum sources. To overcome these problems, focus is towards alternative sources. In this paper the focus is towards biodiesels. Four samples such as Jatropa, Mahua and Neem of B10(diesel 90%, biodiesel 10%), NM25% (Jatropa + Mahua + Neem of 25%, diesel 75%) and JNM30 (Jatropa + Mahua + Neem of 30%, diesel 70%) were used to analyze the performance of IC Engine. Results reveal that JNM 25 and JNM 30 have performance closer to diesel and emissions lower than diesel; and performance is better than B10 blends. Thermal analysis of Piston and Valve is carried out at two temperature zones, 1100K and 1500K. Temperature distribution and heat flux distribution were studied along the length of Piston and Valve. The design found to be safe in the temperature zones.

**Key Words:** Alternative fuel, Diesel Engine, Biodiesel, Variable compression ratio, Emission, Thermal analysis of components

## 1. Introduction

Biodiesel is an alternative fuel for petrol and diesel, which is made from mainly plant oil. Major resources for production of Biodiesel are plant seeds as *Jatropa*, *Karanja*, *Mahua*, *Neem*, *Sunflower seeds*, *cotton seeds* etc. Biodiesel derived from trans-esterification process have low viscosity and properties near to that of diesel, so that it can be used in diesel engine. Use of biodiesel results in lower emission of unburned carbon monoxide, hydrocarbons and particulate. [1] Biodiesel can be blended with diesel in any proportion, in this study the oils used are *Jatropa*, *Neem* and *Mahua*. These oils are blended with diesel in proportion of 10%(B10), further mixtures of three oils in 25%(JNM25) and 30%(JNM30) are studied. These blends are used to study the performance parameters as BSFC, mechanical efficiency, brake thermal efficiency and exhaust gas temperature and are compared with diesel. Also emissions like HC, NO<sub>x</sub>, and CO are compared with diesel. This study is carried out on variable compression diesel engine and two compression ratios CR17.5 and CR 18.5 are used.

Biodiesel has environmental benefits like it has fewer air pollutants than diesel and is nontoxic and biodegradables. Biodiesel is produced from renewable

sources with high energetic efficiency. Energy yield from biodiesel is 40% to 90% more energy than the energy invested in producing it. [2]

Analysis of an IC Engine component is done to optimize the stresses and minimize the weight using ANSYS. The mathematical model of optimization is established firstly, and the FEA is carried out by using the ANSYS software. Based on the results of analysis temperature affected zone is evaluated, which is used to redesign the IC Engine component. [3]

## 2. Biodiesels

### 2.1 *Jatropa curcus* (*Jatropa*):

Government of India has identified *Jatropa* which is non-edible can produce oil which can be easily converted into biodiesel with almost same properties as diesel. *Jatropa curcus* plant is drought resistant, perennial plant which can live up to 50 years and can grow on marginal soils. It does not require lot of water and can grow on any type of soil, hence it is sustainable than any other plant. *Jatropa* seed contains 25-30% oil, in which oil contains 21% saturated fatty acids and 79% unsaturated fatty acids. After transesterification various properties of *Jatropa* oil methyl ester were found close to diesel. [4]

### 2.2 *Azadirachta indica* (*Neem*):

*Neem* is abundantly grown on varied parts of India. The *Neem* can be grown on clay, saline soil and alkaline conditions. Seeds of *Neem* have 30-40% oil as well as free fatty acids about 5.7%. *Neem Oil Methyl Ester* (NOME) is produced after transesterification. Based upon the study carried out by J. Nair and etal [5] on analysis of Performance and Emission on Compression Ignition Engine Fuelled with Blends of *Neem Biodiesel*, it is clear that *Neem biodiesel blends* have higher brake thermal efficiency as compared to diesel. These blends results in no prominent drop in performance of engine. Emission of CO, HC, CO<sub>2</sub>, and NO<sub>x</sub> of *Neem biodiesel* are less comparing with diesel. O<sub>2</sub> emissions of *Neem biodiesel* are more than diesel.

### 2.3 *Madhuca Indica* (*Mahua*):

It is available in Maharashtra, West Bengal, and Orissa and in South Indian forests. It contains 20-25% oil in seeds. In investigation carried out by M. Navindgi and

etal [6] on Performance of CI engine with different blends of Mahua under varying operating conditions, Mahua Oil Methyl Ester (MOME) was blended with diesel in varying proportion and the trials were taken at different conditions like varying injection pressure. As the concentration of MOME in diesel increases power output decreases. But when injection pressure and fuel temperature is increased power output is increased. Blend up to 20% concentration of MOME was found to be suitable for the short term engine performance. Mahua oil is suitable for higher injection pressures (240 bar) and higher inlet fuel temperatures (70°C).

### 3. Biodiesel Properties

Various properties of biodiesels have strong impact on performance and emissions of compression ignition engine. This leads to study the various properties of biodiesels. Fuel selection depends on the parameters like Calorific Value, Viscosity, Density, Flash and Fire Point. On the basis of these properties Jatropha, Neem and Mahua these three oils are selected. Same parameters are studied for the blends B10, JNM25 and JNM30, and are compared with diesel.

Oil used	% Blend	Calorific Value (KJ/Kg)	Viscosity (cSt)	Density (Kg/m <sup>3</sup> )	Flash Point (°C)	Fire Point (°C)
Diesel	100	42514.385	3.00	830	64	70
Jatropha (J)	10	37219.960	4.188	832.648	64	71
Neem (N)	10	36883.125	4.386	837.614	70	78
Mahua (M)	10	39332.65	4.876	840.96	71	78
JNM	25	35235.000	3.625	836.580	72	76
	30	34698.525	4.326	840.170	74	79

Table -1: Properties of biodiesels

As from Table 1 it can be seen that, properties like Calorific Value, Viscosity, Density, Flash Point and Fire Point of blends are closer to the diesel.

### 4. Performance Analysis

#### 4.1 Experimental Setup

To evaluate the performance the selected blends, the experiment is performed on a single cylinder, 4 stroke, Spark/Compression Ignition VCRE, water cooled, naturally aspirated test rig. The engine is coupled with eddy current dynamometer having maximum power of 25 BHP at 4200 to 10000 RPM and with maximum torque capacity of 41.8

N-m at 2700 to 4200 RPM. The load on Engine is varied by controlling the excitation of current to the eddy current dynamometer.

The technical specifications of engine are listed in Table 2.

Engine Parameters	Specifications
Type of Engine	Single Cylinder, 4-Stroke, CI Engine
No. of cylinders	Single
Bore/Stroke	87.5 mm/110 mm
Rated Power	5 BHP at 1500 RPM at 17.5:1
Capacity (cc)	662
Loading	Eddy Current Dynamometer
Manufacturer	M/S Accurate Test Equipment and Engineers, Shirol MIDC, Kolhapur

Table 2: Engine Specifications

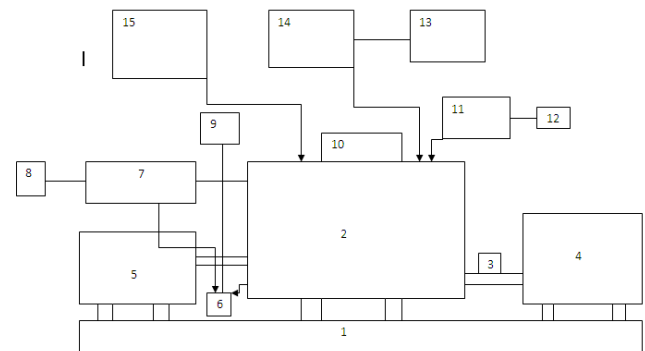

Fig. 1: VCR Engine Layout

1. Engine bed 2. VCR engine 3. RPM sensor 4. Eddy Current 5. D.C. motor 6. Rota meter 7. Exhaust pipe 8. Exhaust gas analyzer 9. Water tank 10. CR lever 11. Air tank 12. Orifice meter 13. Monitor 14. Control Panel 15. Fuel tank

#### 4.2 Engine Performance Characteristics:

Performance parameters like brake specific fuel consumption, brake thermal efficiency, volumetric efficiency, mechanical efficiency, and exhaust gas temperatures are analyzed for blends of Jatropha B10 (J10), Neem B10 (N10), Mahua B10 (M10) and the mix blends JNM25 and JNM30 The tests are performed at CR 17.5 and CR18.5.

##### 4.2.1 Effect of Brake Power on Mechanical Efficiency:

Mechanical efficiency is the ratio of brake power to the indicated power. As the load is increased brake power increases resulting in increase in mechanical efficiency.

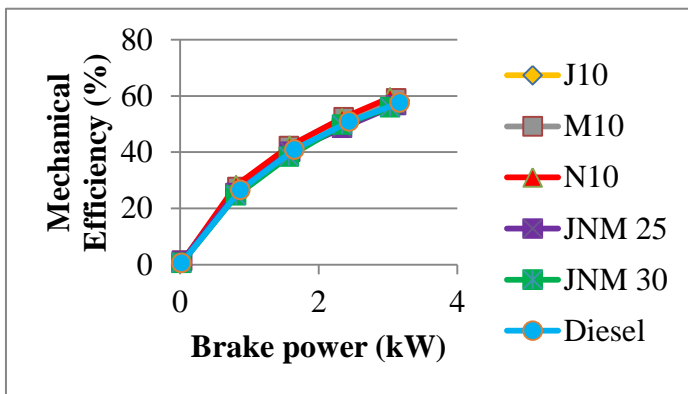

Fig. 2: Mechanical Efficiency Vs Brake Power at CR 17.5

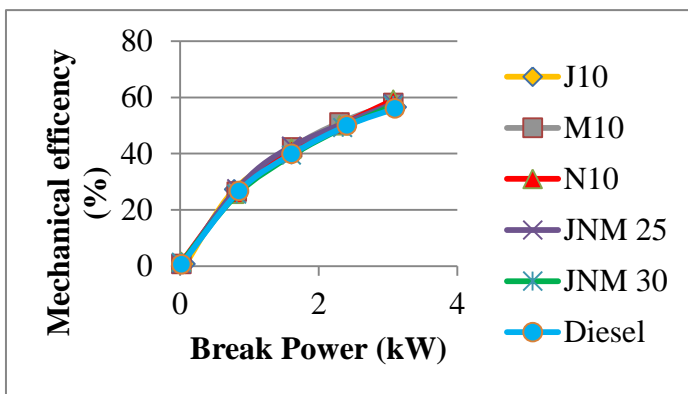

Fig. 3: Mechanical Efficiency Vs Brake Power at CR 18.5

Fig. 2 and Fig. 3 shows, the increase in mechanical efficiency at CR 17.5 for J10, M10 and N10 pure blends compared to diesel at full load is 1.54%, 2.72% and 3.14% respectively. For mix blend JNM 25 at CR 17.5 decrease in mechanical efficiency is 1.44% and for mix blend JNM 30 it is 2.83%. At full load, the increase in mechanical efficiency at CR 18.5 for J10, M10 and N10 pure blends compared to diesel is 0.89%, 3.5% and 5.6% respectively. For mix blend JNM25 at CR 18.5 increase in mechanical efficiency is 3.2% and for mix blend JNM 30 it is 2.1%.

As CR is increased mechanical efficiency is decreased. Comparing the results at CR 17.5 and CR 18.5, decrease in mechanical efficiency for pure blends J10, M10, N10 and mix blends JNM 25, JNM 30 and diesel, at full load, is 3.4%, 1.97%, 0.45%, 0.36%, 1.07% and 3.67% respectively.

**4.2.2 Effect of Brake Power on Brake Thermal Efficiency:**

Brake thermal efficiency is a ratio of power produced to the energy in the fuel burned to produce this amount of power. Brake thermal efficiency increase with the increase in brake power of the engine. This is due to reduction in heat loss and increase in power with the increase in load.

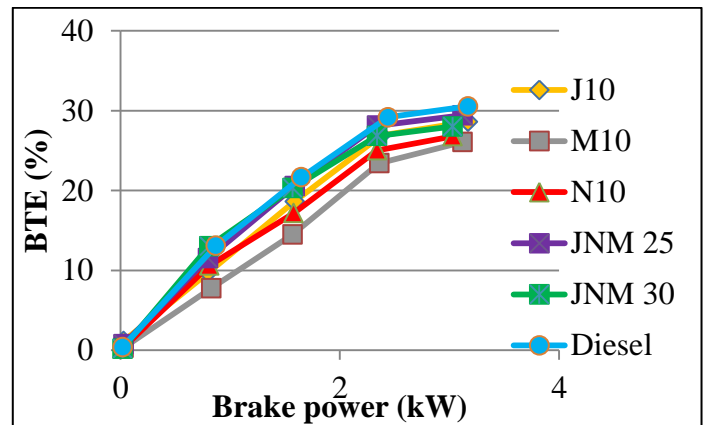

Fig. 4: Brake Thermal Efficiency Vs Brake Power at CR 17.5

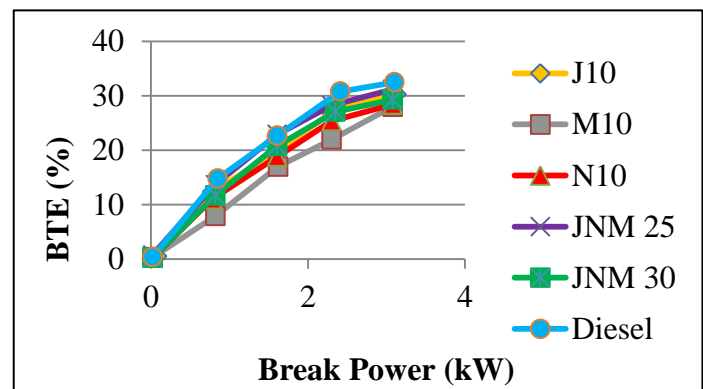

Fig. 5: Brake Thermal Efficiency Vs Brake Power at CR 18.5

Fig. 4 and Fig. 5 shows the decrease in brake thermal efficiency at CR 17.5 for J10, M10 and N10 pure blends compared to diesel at full load is 6.45%, 16.39% and 18.18% respectively. For mix blend JNM 25 at CR 17.5 increase in mechanical efficiency is 7.05% and for mix blend JNM 30 it is 12.88%.

The decrease in brake thermal efficiency at CR 18.5 for J10, M10 and N10 pure blends compared to diesel at full load is 6.74%, 13.82% and 12.59% respectively. For mix blend JNM 25 at CR 17.5 increase in mechanical efficiency is 3.97% and for mix blend JNM 30 it is 9.73%.

As CR is increased brake thermal efficiency is increased. Comparing the results at CR 17.5 and CR 18.5, increase in brake thermal efficiency for pure blends J10, M10, N10 and mix blends JNM 25, JNM 30 and diesel, at full load, is 8.65%, 6.85%, 5.60%, 11.80%, 12.93% and 15.27% respectively.

**4.2.3 Effect of Brake Power on BSFC:**

The Fig. 6 and Fig. 7 shows the variation of BSFC of pure blends J10, M10, N10 and mix blends JNM 25 and JNM 30 at CR17.5 and CR 18.5 respectively. It is observed that as the load increases, cylinder combustion

temperature increases which improves the evaporation of the fuel.

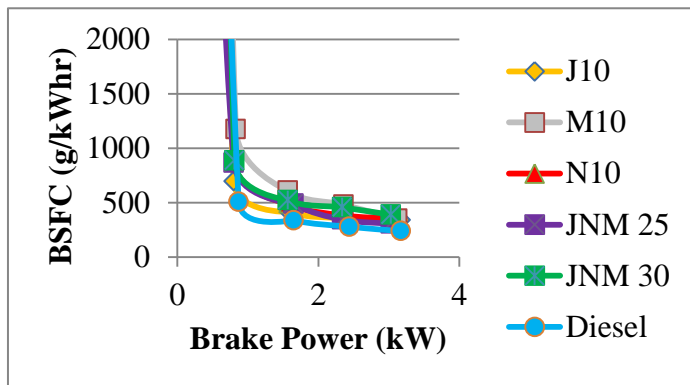

Fig. 6: BSFC Vs Brake Power at CR 17.5

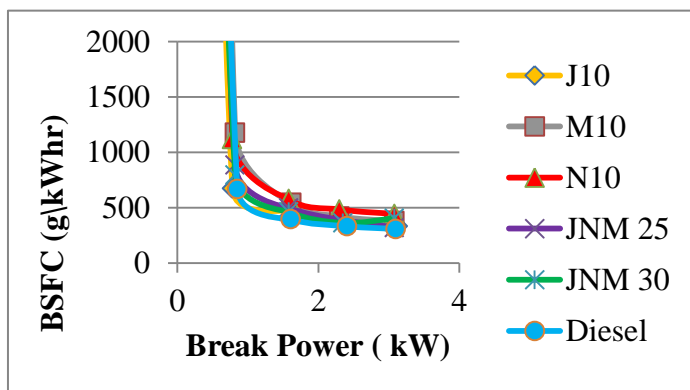

Fig. 7: BSFC Vs Brake Power at CR 18.5

At high load the complete fuel evaporates in less time which improves air fuel mixture. So the complete combustion occurs and reduces BSFC. BSFC of biodiesel blends is more than diesel due to lower values of CV of biodiesels.

The increase in BSFC for J10, M10 and N10 blends compared to diesel at full load is 41.44%, 46.25% and 48.49% respectively at CR 17.5. For JNM 25 increase in BSFC at CR 17.5 is 28.47% and for JNM 30 it is 62.32%.

The increase in BSFC for J10, M10 and N10 blends compared to diesel at full load is 7.77%, 22.81% and 44.02% respectively at CR 18.5. For JNM 25 increase in BSFC at CR 18.5 is 3.68% and for JNM 30 it is 31.54%.

As CR is increased BSFC is decreased. Comparing the results at CR 17.5 and CR 18.5, decrease in BSFC for J10, M10, N10, JNM 25, JNM 30 and diesel, at full load, 13.98%, 13.73%, 19.81%, 14.76%, 16.34% and 22.23% respectively.

#### 4.2.4 Effect of Brake power on Exhaust Gas Temperature:

The Fig. 8 and Fig. 9 show the variation of Exhaust Gas Temperature of pure blends J10, M10, N10 and mix blends JNM 25 and JNM 30 at CR17.5 and CR 18.5

respectively. It is observed that Exhaust gas temperature increases with BP. This is due to increase in pressure inside cylinder as well as complete burning of fuel. Mainly exhaust gas temperature is dependent on the flash point temperature and the viscosity of the fuel. Higher the flash point temperature and higher the viscosity then the exhaust gas temperature is higher. It is observed that Diesel has the least exhaust gas temperature than all the blends. It is because it has the less viscosity and flash point than all the blends.

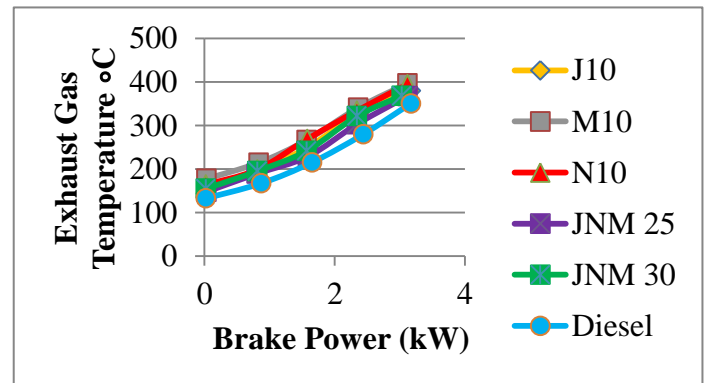

Fig. 8: Exhaust Gas Temperature Vs Brake Power at CR 17.5

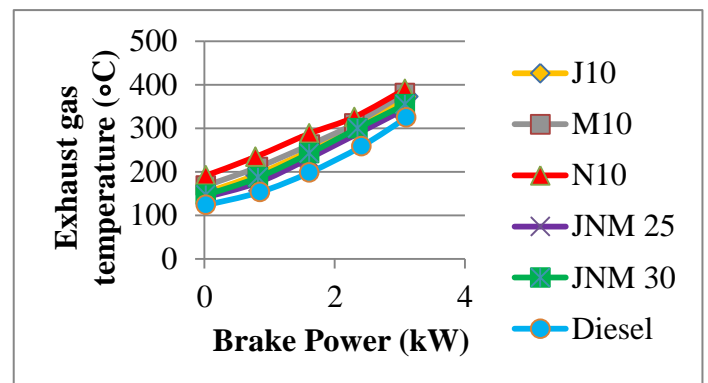

Fig. 9: Exhaust Gas Temperature Vs Brake Power at CR 18.5

The increase in exhaust gas temperature for J10, M10 and N10 pure blends compared to diesel at full loads is 8.81%, 13.11% and 12.57% respectively at CR 17.5. For mix blend JNM 25 increase in exhaust gas temperature at CR 17.5 full load is 4.81%. For mix blend JNM 30 at CR 18.5 increase in temperature at full load is 4.96%.

The increase in exhaust gas temperature for J10, M10 and N10 pure blends compared to diesel at full loads is 14.69%, 17.22% and 20.08% respectively at CR 18.5. For mix blend JNM 25 increase in exhaust gas temperature at CR 18.5, at full load, is 6.03%. For mix blend JNM 30 at CR 18.5 increase in temperature at full load is 4.96%.

As CR is increased exhaust gas temperature is decreased. Comparing the results at CR 17.5 and CR 18.5, decrease in exhaust gas temperature for pure blends J10,

M10, N10 and mix blends JNM 25, JNM 30 and diesel, at full load, is 1.89%, 4.10%, 1.29%, 6.39%, 3.66% and 7.46% respectively.

### 4.3 Emission Analysis:

The use of Petroleum based fuels has been increased in industries and automobiles, which has lead to problems like pollution, energy crisis and global warming. Biodiesels such as Jatropha, Mahua and Neem produces less emissions than petroleum based fuels.

#### 4.3.1 Effect of Brake Power on HC emissions:

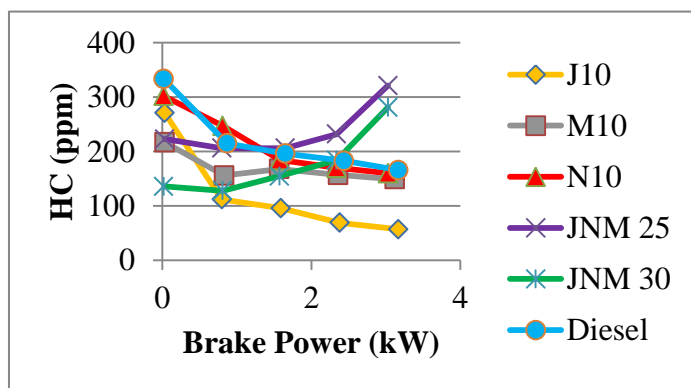

Fig. 10: HC emissions at CR 17.5

The Fig. 10 shows the HC (hydrocarbon) emission vs. the brake power at CR 17.5. Hydrocarbon emission is due to the incomplete combustion. From fig. it shows that the HC emission goes decreases as CR increases from 17.5 to 18.5. The unburnt hydrocarbon emission decreases with the increase in load as shown in the Fig. due to the sufficient amount of oxygen in the mixture. At no-load unburnt hydrocarbon, emission reduces up to 18% in Jatropha, 10% in Neem and up to 25% for Mahua as compared with diesel. At full load HC emission decreases up to 3.14% and 3.61% for M10 and N10 respectively. JNM25 produces maximum emission of HC at full load up to 321ppm compared to 166ppm of diesel.

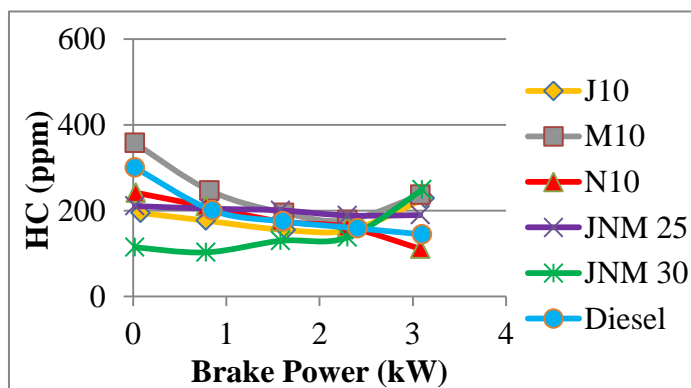

Fig. 11: HC emissions at CR 18.5

The Fig. 11 shows the relation between the hydrocarbon emission and brake power. vs. break the power at compression ratio 18.5. The maximum emission

of HC produced by Mahua up to 19% more than diesel at low load. For Neem, it decreases up to 19% and for Jatropha its 35% less than diesel emission at no load. As load increases HC emission decreases up to certain limits and then increases as shown in the fig. For JNM25 the emission of HC decreases with the increase in load and emission HC emission reduces up to 25% than diesel at no load. Pure blend of J10 has least HC emission as compared to other pure blends and mix blends at CR17.5. Pure blend of N10 has least HC emission as compared to other pure blends and mix blends at CR18.5.

#### 4.3.2 Effect of Brake Power on CO emissions:

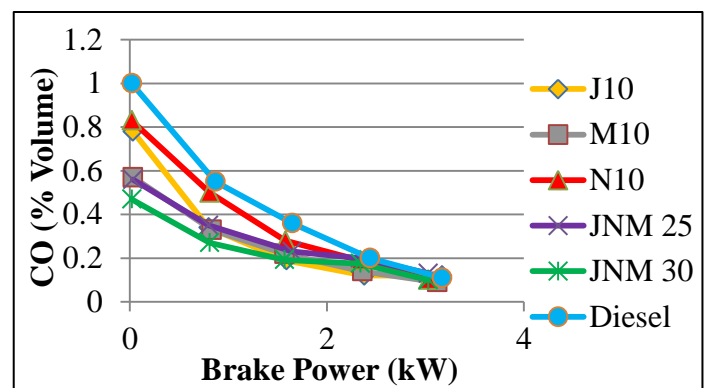

Fig. 12: CO emissions at CR 18.5

The Fig. 12 shows the emission of CO (carbon monoxide) vs. break the power at CR 17.5. The main effect of methyl based fuel is oxygen content and the cetane number. As the combination of methyl ester fuel contains some oxygen, which helps in the combustion of the fuel. Oxygen helps in better combustion of fuel, which converts CO into CO<sub>2</sub>. Hence CO present in the exhaust reduces drastically. The diesel contains fewer amounts of Oxygen than different blends of selected biodiesels due to which the CO emission is more in the diesel. At no load CO emission in Mahua is less up to 18% than the diesel. The Neem and Jatropha produce maximum CO up to 0.12% volume which is nearer to diesel. JNM25 produce CO up to 35% less than diesel at no load and equal emission at full load. JNM30 has CO emission up to 10% less than diesel.

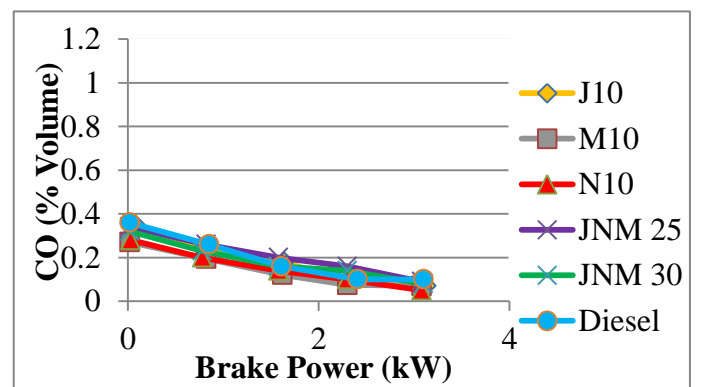
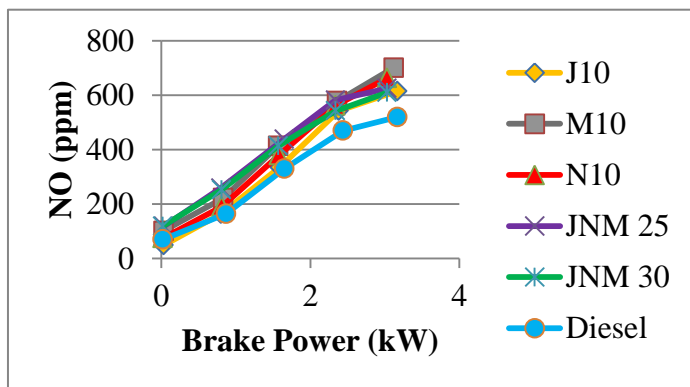

Fig. 13: CO emissions at CR 18.5

The Fig. 13 shows the relation between carbon monoxide vs. break power at varying load condition. As the compression ratio increases the CO emission decreases. At CR 18.5 the Jatropha produces more CO percentage volume and equal to the diesel emission. The Mahua produces 0.27% of volume CO as compared to diesel 0.36% of volume at no-load condition. It reduces up to 25% as compared with diesel. The Jatropha produce more CO emission up to 30% greater than diesel at full load. Pure blend of N10 shows least CO emission.

**4.3.3 Effect of Brake Power on NO emissions:**



**Fig. 14:** NO emissions at CR 17.5

The Fig. 14 shows the variation of NO emission vs. the break power of the engine with respect to CR 17.5. The NO emission mainly depends on the maximum combustion temperature. Highest combustion temperature breaks the strong triple bond of nitrogen, which reacts with oxygen and forms the oxide of nitrogen. As load on the engine is increased the temperature of combustion also increases. The maximum temperature of combustion is full in Mahua at full load. Mahua produces maximum NO up to 701 ppm which is 34% more than diesel. The minimum emission is produced by Jatropha up to 615 ppm which is 18% more than diesel at full load. The Neem produces NO up to 663 ppm which is 27% more than diesel at full load. The NO emission reduces in JNM 30 compared to JNM 25 as oxygen contains increases.

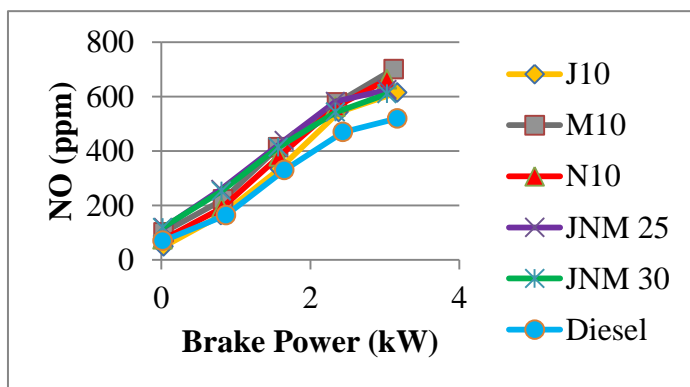

**Fig. 15:** NO emissions at CR 18.5

The Fig. 15 shows the variation of NO vs. break the power at 18.5 CR. With increase in CR the NO emission increases because of increase combustion temperature. As the load on an engine increases the NO emission also increases. The maximum NO emission is produced by J10 and N10 blends at full load and having 3% more than diesel emission. The Mahua oil produces less NO emission than other two blends having 3-4% reduction as compared to diesel. Jatropha produces maximum emission of NO at full and load up to 3% and 23% increases as compared to diesel. The JNM25 produces 25% increase in NO emission as compared to diesel. Pure blend of J10 shows the least NO emission.

**5. Thermal Analysis**

**5.1 Thermal Analysis of Piston:**

The thermal analysis include: heat transfers along piston and thermal boundary conditions applied to a piston. Calculate the temperature and heat flux distribution in the piston.

This is very important to determine the temperature distribution along a piston so as to check thermal stresses as well as deformations within permissible limits. This enables to optimize thermal aspects to design piston, prior to construction of the first prototype. The skirt surface of a piston slides on the cylinder bore. Clearance between cylinder and piston is filled with lubricant film. Small values of clearance increase frictional losses, and higher values increase the piston secondary motion. Pistons are typically made of an aluminium alloy. It has a high coefficient of thermal expansion. It is nearly 80% higher than the cylinder bore. Material of bore is cast iron. Hence piston thermal analysis is necessary in design of an efficient engine. Thermal analysis is carried out in ANSYS 15.0.

Dimension of piston are as follows;

Design Dimension	Size in mm
Length of piston	92
Outer diameter of piston	88
Radial thickness of ring	3.4
Axial thickness of ring	2.1
Maximum thickness of barrel	10.9
Width of top land	11.5

**Table 3:** Dimensions of Piston

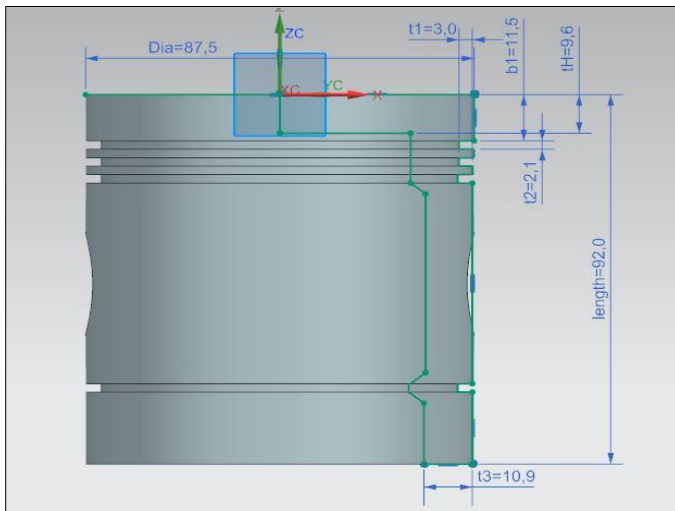

Fig. 16: NX-CAD model of piston

5.1.1 Thermal analysis of piston at 1100K:

The temperature distribution in the piston enables to check where the maximum and minimum temperature is present. Fig. 17 and Fig. 18 show that the maximum temperature is on the top surface of piston, and the minimum temperature is on the piston skirt. The temperature distribution of the piston is from 453 K min to 1100 K max. Fig. 4.3 and fig. 4.4 show the heat Flux range from 2.14 W/mm<sup>2</sup> minimum to 19.3 W/mm<sup>2</sup> maximum. Temperature of 1100 K is applied for thermal analysis. Generated heat flux is in safe condition. It is indicated by blue colour portion. Design and material are safe. Deformation is less.

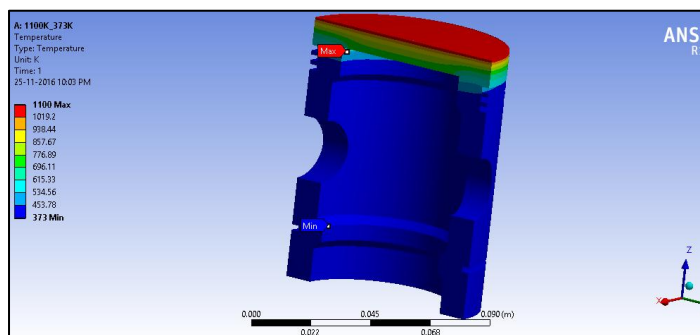

Fig. 17: Temperature Distribution of Piston at 1100K

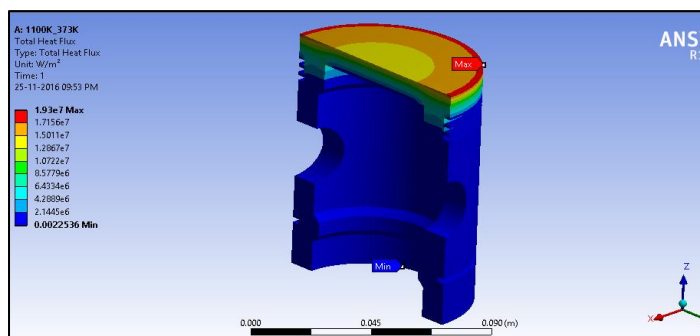

Fig. 18: Heat Flux Distribution of Piston at 1100K

5.1.2 Thermal analysis of piston at 1500K:

The temperature distribution in the piston enables to check where the maximum and minimum temperature is present. Fig.19 and Fig.20 show that the maximum temperature is on the top surface of piston, and the minimum temperature is on the piston skirt. The temperature distribution of the piston is from 498 K min to 1500 K max. Fig 4.6 and fig. 4.7 show that heat flux range from 3.32 W/mm<sup>2</sup> minimum to 29.9 W/mm<sup>2</sup> maximum. Temperature of 1500 K is applied for thermal analysis. Generated heat flux is in safe condition. It is indicated by blue colour portion. Design and material are safe. Deformation is less.

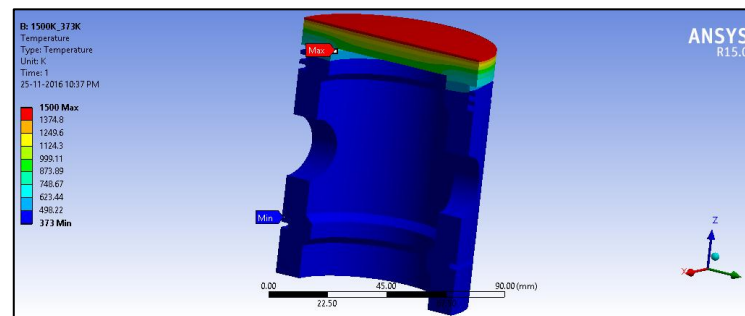

Fig. 19: Temperature Distribution of Piston at 1500K

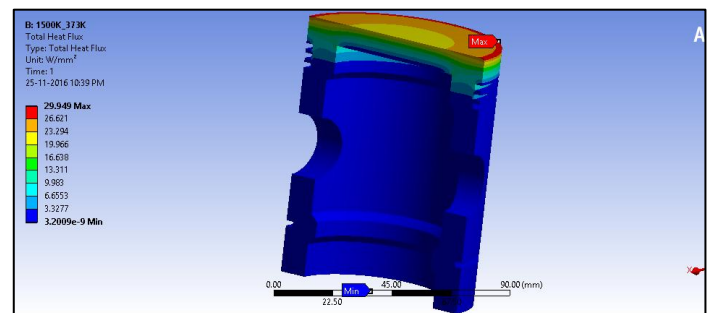

Fig. 20: Heat Flux Distribution of Piston at 1500K

5.2 Thermal Analysis of Valve:

Engine valve's location is in the engine cylinder head. The prominent function of the valves is to let surrounding air in and exhaust gases out of the cylinders. That inlet air is used to ignite the fuel which will initiate the piston motion.

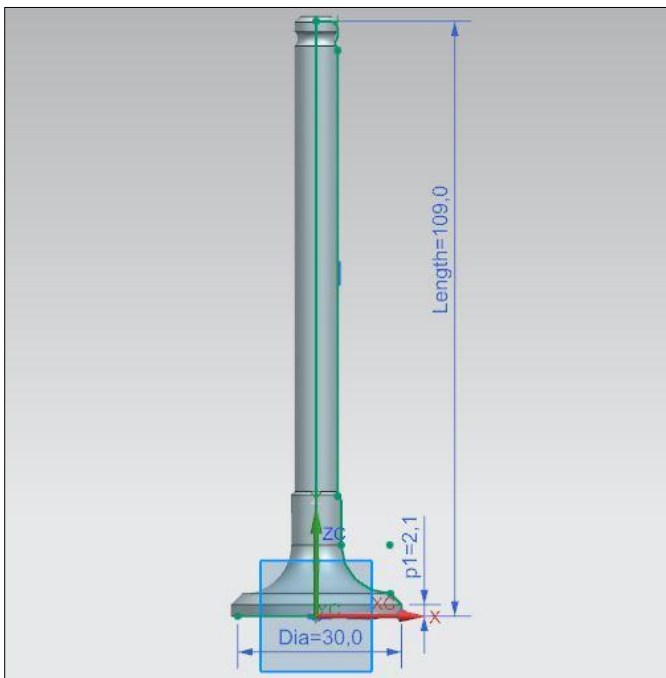

Fig. 21: NX-CAD Model of Valve

Thermal analysis is done for two temperatures, which are 1100 K and 1500 K. This temperature is applied to the bottom surface of valve seat. Side surfaces of valve are selected for convection. Stagnant water convection is considered. Film coefficient is taken as  $12 \cdot 10^{-003} \text{ W/mm}^2$ . Here, study is oriented in finding temperature and total heat flux distribution in the valve.

Properties of Titanium alloy:

Density =  $4620 \text{ kg/m}^3$

Thermal Conductivity =  $21.9 \text{ W/m}^\circ\text{C}$

Specific Heat =  $522 \text{ J/kg}^\circ\text{C}$

### 5.2.1 Thermal analysis of valve at 1100K:

The temperature distribution in valve enables to check where the maximum and minimum temperature is present. Fig. 22 shows that the maximum temperature is on the top surface of valve, and the minimum temperature is on the valve skirt. The temperature distribution of the valve is from 384.9 K min to 1100 K max. Fig. 23 shows heat flux range from  $1.73 \text{ W/mm}^2$  min to  $7.80 \text{ W/mm}^2$  max. Temperature of 1100 K is applied for thermal analysis. Generated heat flux is in safe condition. It is indicated by blue colour portion. Design and material are safe. Deformation is less.

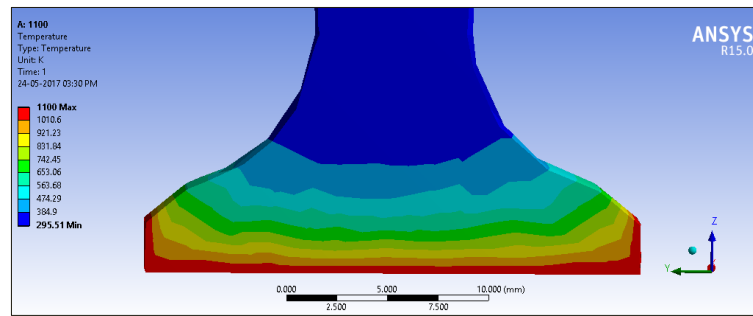

Fig. 22: Temperature Distribution of Valve at 1100K

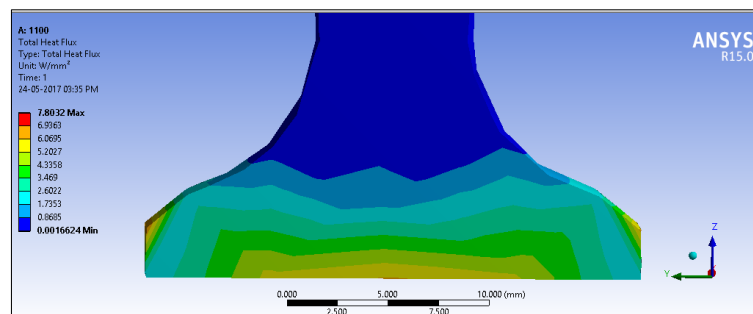

Fig. 23: Heat Flux Distribution of Valve at 1100K

### 5.2.2 Thermal analysis of valve at 1500K:

The temperature distribution in valve enables to check where the maximum and minimum temperature is present. Fig. 24 shows that the maximum temperature is on the top surface of valve and the minimum temperature is on the valve skirt. The temperature distribution of the valve is from 429 K min to 1500 K max. Fig. 25 shows heat flux range from  $2.53 \text{ W/mm}^2$  min to  $11.39 \text{ W/mm}^2$  max. Temperature of 1500 K is applied for thermal analysis. Generated heat flux is in safe condition. It is indicated by blue colour portion. Design and material is safe. Deformation is less.

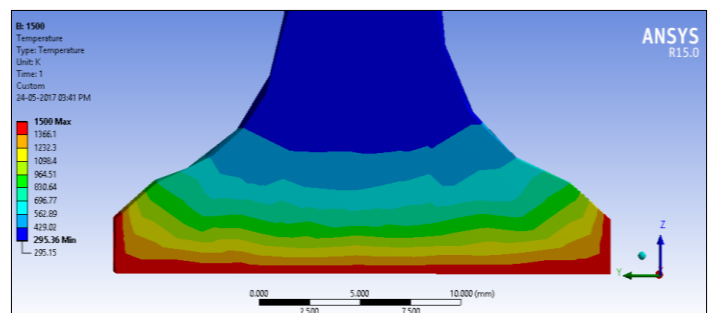
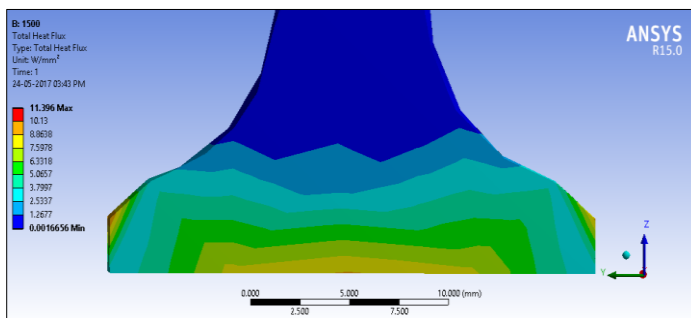

Fig. 24: Temperature Distribution of Valve at 1500K





**Fig. 25:** Heat Flux Distribution of Valve at 1500K

## 6. Conclusions

Performance results reveal that mix blend of JNM25 at compression ratio 18.5 has performance better than any other blend studied which is closer to the diesel. Mechanical efficiency and Brake Specific Fuel Consumption are higher than diesel by 4.63% and 3.62%. Brake thermal efficiency is lower than diesel which is 4.24%, Exhaust gas temperature shows 14.70% high value at no load and 6.03% high value at full load than diesel.

Emission analysis shows that for all blends, emission of hydrocarbon and carbon monoxide are decreased whereas NO emission are increased. The biodiesel pure blend B10 of Mahua, Jatropha and Neem have about 20% more emission of NO (oxides of nitrogen) than diesel. The hydrocarbon and carbon monoxide emission decreases up to 25% as compared to diesel at no load. The JNM25 gives 30% less emission of CO than diesel at different loads. The mix blend JNM25 is best suitable for replacement of diesel.

Thermal analysis of IC engine piston and engine valve is done at 1100 K and 1500 K. Temperature and Total Heat Flux distribution of the component is analyzed. Generated heat flux is in safe condition. Hence, design of selected parts and material are safe.

## 7. References

- [1] Avinash Kumar Agarwal, "Biofuels (alcohols and biodiesel) applications as fuels for IC engine", *Progress in Energy and Combustion Science* 33 (2007)pp. 233-271.
- [2] Amol M., Dhote, Priya S. and Ganvir V.N, "Production of Neem Oil Methyl Ester (NOME) from Oscillatory Baffled Reactors Ramming", *Research Journal of Recent Sciences* Vol. 2(2013), pp. 223-228.
- [3] K Ramesh Babul, G Guru Mahesh, G Harinath Gowd. "Modeling and Thermal Analysis of SI Engine Piston Using FEM", *International Journal of Mechanical Engineering and Robotics research*, Vol. 3, (2014) pp 266-271.
- [4] Sunil Kumar, Alok Chaube, Shashi Kumar Jain, "Experimental evaluation of CI engine performance using Diesel blended with Jatropha Biodiesel" *International*

*Journal of Energy and Environment*, Volume 3, Issue 3, (2012), pp. 471-484.

[5] Jayashri N. Nair, Ajay Kumar Kaviti, Arun Kumar Daram, "Analysis of Performance and Emission on Compression Ignition Engine Fuelled with Blends of Neem Biodiesel" *Egyptian Journal of Petroleum*, (2016) pp. 1-5.

[6] M. C. Navindgi, Maheswar Dutta, B. Sudheer Prem Kumar, "Performance of a CI Engine with Different Blends of Mahua (*Madhuca Longifolia*) Biodiesel under Varying Operating Conditions", *International Journal of Engineering and Technology* Volume 2 No. 7, 2012, pp. 1251-1255.