

## Regenerative Braking System

Anand Kumar<sup>1</sup>, Amit Goyal<sup>2</sup>, Prof. Narendra Singh Sikarwar<sup>3</sup>

<sup>1,2</sup>Student, Department of Mechanical Engineering, Madhav Institute of Technology and science, Gwalior, Madhya Pradesh, India

<sup>3</sup>Assistant Professor, Department of Mechanical Engineering, Madhav Institute of Technology and science, Gwalior, Madhya Pradesh, India

\*\*\*

**Abstract** - In any vehicle the conventional brake when applied converts kinetic energy into heat in order to slow down a vehicle or to make it stop, but while braking a lot of usefull energy as heat dissipates in environment and gets wasted. This project aims to create a regenerative braking system for an electric vehicle used to recover energy on board rechargeable power supply which converts kinetic energy from wheel into electric energy, thus will harness this wasted energy and store it for further use whenever demanded and thus can help to reduce fuel consumption and improve efficiency of electric vehicles through braking as it result in an increase energy output for given energy input to the vehicle. It is done by a motor converting KE to electricity which is stored in battery, transducer, a process sensor and a microprocessor. Again when acceleration is throttled energy is reused to provide acceleration to vehicle. Also it reduces tear and makes it long lasting.

**Key Words:** Regenerative system, electric motor, electric vehicles, arduino uno, microprocessor.

### 1. INTRODUCTION

At present air pollution is increasing by a huge numbers of IC engines used in two wheel drives. It has become necessary in large cities having high population density with high concentration of two wheeler powered by IC engines which produce large quantities of pollutants and noise in cities to be minimized and efforts are being made to decrease the pollution by replacing IC engines with an alternative power source such as an efficient electric powered vehicles which emits substantially no pollutants and minimize noise pollution too will surely put a restraint in increasing carbon and pollutants emission leading to global warming which is responsible for changing in climate of earth.

Electric vehicles uses rechargeable batteries to to provide power to drive the motor and needs to be charged time to time. In a busy city driving in where traffic jams are common and driver has to start..stop..start..stop again and again before reaching to his destination. This causes a huge amount of waste of time and energy when conventional braking are applied. Also increases pollution, noise and unnecessary fuel consumption. Rising cost of fuel, carbon emissions and desire for extended driving range is leading to a rise in technology. Researchers are trying to improve not just IC engines and batteries storage capacities but also to minimize the loss of energy wherever possible.

Regular brakes waste large amounts of use able energy. Regenerative braking overcomes much of problems as almost 62.5% of energy is wasted through frequent braking in town driving, it use the engine to harness this energy When slowing down, the engine switches to reverse mode The kinetic energy from the engine is transferred to the battery Regular breaks use friction to convert the kinetic energy of the wheels into heat to slow down the vehicle. This heat is a huge amount of energy that is harnessed through regenerative breaking. A regenerative breaking system actually has little to do with the conventional breaking systems. When the break pedal is depressed, the engine actually switches to reverse mode and begins moving in the opposite direction. This provides a braking System that is more energy efficient, and Simpler, than that provided by friction brakes.

So in order to increase the driving range of electric vehicle minimizing the wasted energy by using on board regenerative braking is the only way to charge the battery without another mechanical connection, Not only it does improve fuel efficiency in EV, but also it can be adapted for the ICV to help lower vehicle emissions.

### 1.1 LITERATURE REVIEW

Author Jarrad Cody, Özdemir Göl, Zorica Nedic, Andrew Nafalski, Aaron Mohtar carried out a research activity focused on the Regenerative braking in an electric vehicle The system employs the Independent Switching strategy to control the flow of current during various stages of the cruise profile. The work is in progress to fit with the commercial BLDC motor and a commercial power supply together with the controller developed in-house .

Another System known for controlling regenerative braking in an electric vehicle is disclosed in U.S. Pat. No. 5,615,933 which discloses a four wheeled vehicle having an electric propulsion motor, a regenerative brake control, and a friction anti-lock brake System (ABS) in which regenerative braking may be blended with friction braking when anti-lock braking is not activated. Regenerative braking, however, is ramped down or immediately removed when antilock braking is activated.

Similarly, U.S. Pat. No. 5,472,265 discloses an antilock braking apparatus having a regenerative braking part, a Second braking part, an antilock brake System part, and a braking control part in which the antilock brake System

part performs an ABS control process to control a braking force produced by either the regenerative braking part or the Second braking part on the wheels. The braking control part changes the braking force produced by the other braking part on the wheels to equal Zero when the antilock brake System part has started performing an ABS control process.

S. Suyambazhahan worked on Regenerative brakes system used in an Automobile Engine. Hybrid concept has gained momentum nowadays at the height of energy crisis. Moreover, pollution control and strict emission norms has resulted in fast development of electric vehicle and Hybrid vehicle. This regenerative braking system envisages charging of a 12V automobile battery by operating an alternator engaged to the main shaft by using a magnetic clutch while braking. In the present experimental study up to 2.9kW of energy is recovered while braking. Electrical energy thus obtained is used in operating various electrical fittings in the automobile and converting the vehicle into a Hybrid Electric Vehicle (HEV). Vast reduction in emission levels and overall improvement in efficiency is achieved [4].

## 2. BLOCK DIAGRAM

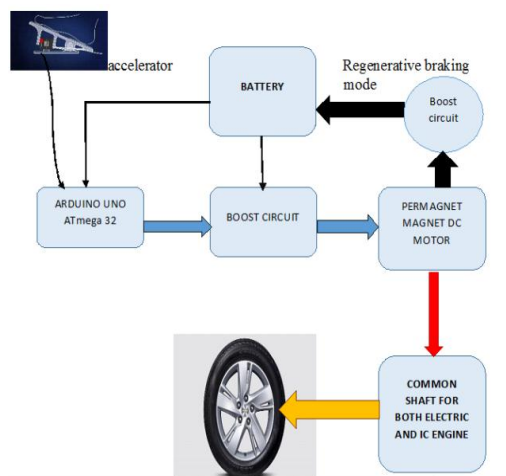

Fig 1. Block diagram description in Regenerative Braking

## 2. 1 COMPONENT LIST

List of Component putting cost to a minimum and advancement in technology this braking system is modified for light vehicles

Main Component used in the system:

1. Arduino Uno GeATmega 32 microcontroller
2. Boost circuit

3. Permanent magnet dc motor with gear arrangement
4. Battery
5. Drive shaft

## 2. 2 COMPONENT DESCRIPTION

### Arduino Uno

Arduino Uno is an open-source microcontroller. It is based on ATmega328P. It consists of fourteen digital pins for input and output. Six analog input pins, a sixteen-megahertz ceramic resonator, a Universal Serial bus connection, a power jack, an ICSP header and a reset button. Figure-1[4] shows different parts of the Arduino uno board.

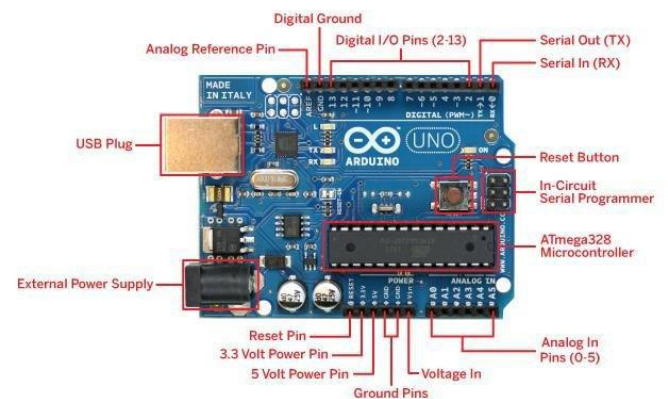

Figure-1: Arduino Uno board

**Electric motor:** An Electric motors is an electrical device that converts electrical energy into mechanical energy. In normal motoring mode mostly operate through the interaction between electric and magnetic fields and winding to generate force inside motor. Besides it performs additional function such as providing an supporting torque to vehicle while accelerating the it upto a speed (for eg:45km/hr). While we step on brakes this motor operates in the regenerative braking mode generating power from the wheels and storing the energy generated in the battery.

The voltage equation of the permanent magnet dc motor is

$$V = E_b + I_a R_a$$

Where,

V = applied voltage

$E_b$  = back emf voltage

$I_a$  = Armature current

$R_a$  = Armature resistance

**BOOST CIRCUIT:**

A **boost converter (step-up converter)** is a DC-to-DC power

converter that steps up voltage (while stepping down current) from its input (supply) to its output (load) The output of the boost circuit is given by

$$V_{out} = V_{in} / (1-D)$$

Where,

Vout = Output voltage Vin = Input voltage D = Duty cycle

Duty cycle calculation is given by

$$\text{Duty cycle} = 1 - (V_{in}/V_o)$$

Where

Vin = Input voltage

Vo = Output voltage

As per our requirements the duty cycle calculated is 0.67

The first boost circuit boosts up the supply voltage to the motor. The voltage obtained from the regenerative braking mode is boosted up by second boost circuit and is given to the battery.

**Wheel:** Wheel gets in motion with help of running motor. Both motor and wheel is connected through a chain and gear mechanism.

**Battery:** This division consists of power supply to whole system. Having **24 V 14 amps/hour**.

**Bearing:** The purpose of ball bearing is to reduce rotational friction and support radial and axial loads. In this project 608 2RS type of bearing is used.

**DRIVE SHAFT:**

The drive shaft is necessary for the transmission of power from the IC engine to the wheels and from the electric motor to the wheels through single gear arrangement.

**3. WORKING :**

Regenerative braking is a braking method of converting kinetic energy of the wheels of vehicle into electrical energy and give back to the battery.

In the regenerative braking mode, the motor slows downhill the vehicle. When we apply force to pedal of brake, then it gets slow down and motor works in reverse direction. When running in invalidate direction motor acts as the generator and thus charge the battery as shown in

figure. the car which is running in normal condition where motor goes forward and takes energy from the battery.

Simplest scheme for vehicle regenerative braking

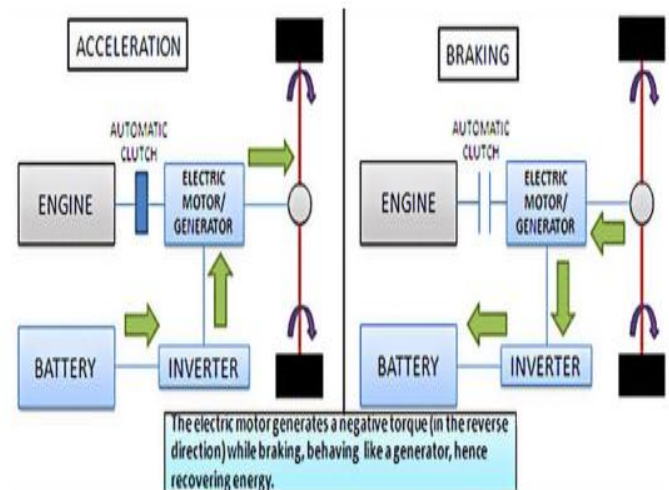

**Regenerative action during braking**

This brakes work so effectively in driving in such environment so as to stop in cities. The braking system and controller is the feeling of the structure because it controls the whole part of vehicles of the motor. The brake controller functions are monitor the speed of the wheel, hence calculate the torque, electricity which is to be generated and rotational force thus to be feed to batteries. When we apply brakes the brake controller, it controls and direct the electrical energy which is formed by the motor to the batteries.

**SIMULATION**

**INTRODUCTION**

The working model of project is done by software help called MATLAB. This is done to check the feasibility of work. Here the simulation for boost converter is done and the boosted voltage is fed to the permanent magnet dc motor and its properties are studied. Likewise for regenerative braking the back emf generated is greater than the supply voltage and the motor corresponding properties are studied.

**MOTORING ACTION**

During this the input supply voltage is greater than the back emf produced so the motor runs.

Here motor input voltage : 24V

Back emf produced : 12V

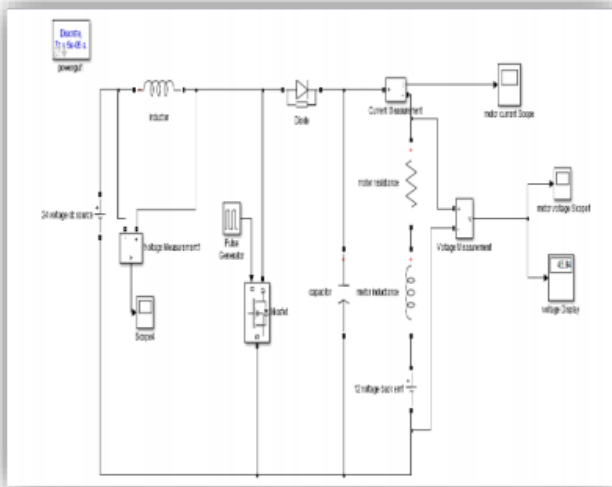

Fig. Circuit diagram for Motoring action

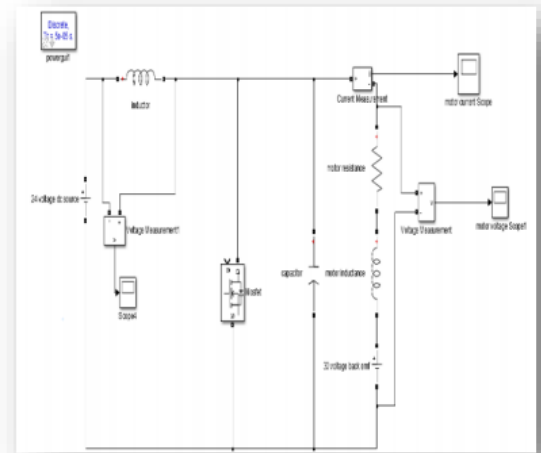

Fig. Circuit diagram for Regenerative Braking action.

**SIMULATION RESULT**

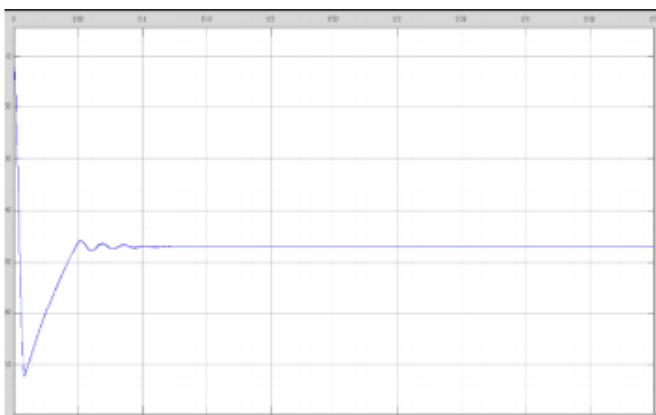

Fig. Voltage waveform for motoring action

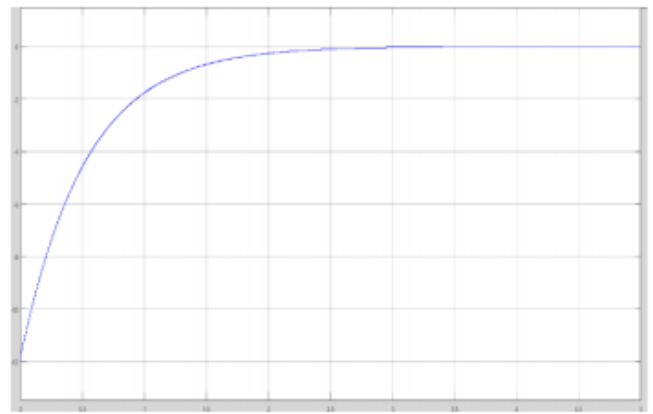

Fig. Voltage waveform for regenerative Braking action

**REGENERATIVE BRAKING MODE**

During this the back emf generated is greater than the input supply voltage so the motor speed reduces due to regenerative braking mode.

Here Back emf produced : 30 V

Input supply voltage : 24 V

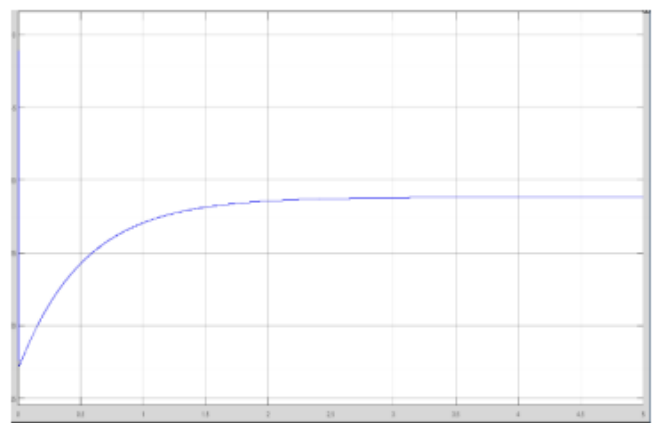

Fig. Current waveform for regenerative Braking action

#### 4. CALCULATIONS : Calculating regen savings

Let's first consider both the benefits and practical limits of regen in an EV by analyzing a simple yet realistic hypothetical situation:

Using the equation for kinetic energy ( $Kjoules = 0.5mv^2$ ) for a 1,000 kg vehicle decelerating from a speed of 100 kph gives a result of 384 kW (kilowatt-seconds). Dividing that by 3,600 to convert seconds to hours gives us a rather paltry 0.11 kWh of recovered energy – assuming 100% efficiency.

Multiply 0.11 kWh by the rate for electricity of rupees 5/kWh and the resulting savings is 0.55 rupees.

#### 5. CONCLUSION

The theoretical investigation shows vehicle that makes frequent stops it can significantly help improve fuel economy of vehicle driven primarily in city about 25% savings in fuel consumption. So also meaning less pollutants emissions and and increase in engine life. Regenerative braking is an effective method of improving vehicle efficiency and longevity in EVs. It is clear that when the torque driven by the vehicles is measured. Electrical power generated by motor, generator and battery is very useful and hence it should be used in electric vehicles.

#### 6. ACKNOWLEDGEMENT

We would really like to thank our guide Mr. Narendra Singh Sikarwar. Department of Mechanical Engineering MITS Gwalior, for his valuable suggestions, constant support and encouragement.

#### 7. REFERENCES

1. Jarrad Cody, Özdemir Göl, Zorica Nedic, Andrew Nafalski, Aaron Mohtar, "Regenerative braking in an electric vehicle", 2009.
2. U.S. Pat. No. 5,615,933
3. U.S. Pat No. 6,724,165 B2
4. S. Suyambazhahan "Experimental Study of Regenerative Brakes System used in an Automobile Engine", 2011
5. 5. Santhanakrishna thirumalai ENERGY EFFICIENT REGENERATIVE BRAKING IN VEHICLES
6. CHARGED : Electric Vehicle Magazine
7. IDTechEx research articles
8. Pratik P. Shinde. "A seminar on regenerative braking stsem".