

Implementation of an Off-Hospital Rural & Urban Public Access Defibrillator

Sahana.D¹, Madhu.G², Sahana K.G³, Mrs Jayasudha B.S.K⁴,

¹⁻³Student, Dept. of ECE, K S Institute of Technology, Bangalore, Karnataka

⁴Asst. Prof., Dept. of ECE, K S Institute of Technology, Bangalore, Karnataka

Abstract - The occurrence of cardiac arrest (OHCA) out-of-hospital is a critical life-threatening event which often warrants early defibrillation with a semi-automated external defibrillator (SAED). Death statistics study shows that cardio-vascular diseases rank first in the leading cause of death with 28 percent of total death seen in the 25-69 age group. In INDIA, about 4280 deaths in 1Lakh are due to SCA. The optimization of allocating a limited number of SAEDs in various types of communities is challenging. Hence this paper presents the implementation of an off-hospital rural and urban public access defibrillators. This defibrillator is a semi-automated defibrillator, a medical device which analyze the patient's electrocardiogram in order to establish whether he/she is suffering from ventricular fibrillation and if necessary, delivers an electric shock, or defibrillation, to help the heart re-establish an effective rhythm.

Keywords: Ventricular defibrillation, Electrocardiogram, Automated external defibrillator, Cardiopulmonary resuscitation.

1. INTRODUCTION

Cardiovascular disorders account for 24.8 per cent of the country's overall deaths. The age group is mainly affected by this disease.

Many sudden heart deaths result from irregular heart rhythms called arrhythmias. Ventricular fibrillation is the most common life-threatening arrhythmia which is an irregular, disorganized firing of impulses from the ventricles (lower chambers of the heart). When this happens the heart can not pump blood, and if left untreated, death will occur within minutes.

An AED is a tool that provides a therapeutic dose of shocks to help restore a victim of cardiovascular trauma to the steady heart rhythms. AEDs are designed to be simple to use with simple pictorial commands for the layperson.

The rhythms the device will treat will typically be limited to:

1. Ventricular pulseless tachycardia (shortened to VT or V-Tachus).
2. Ventricular (shortened to VF or V-Fib) fibrillation.

In each of these two types of shockable cardiac arrhythmia, the heart is electrically active but in a dysfunctional pattern that doesn't allow it to pump and circulate blood. During ventricular tachycardia the heart beats too hard to properly pump blood. Ventricular tachycardia eventually leads to the ventricle fibrillation. In ventricular fibrillation, the heart's electrical activity is erratic, thereby stopping the ventricle from pumping blood effectively. The fibrillation in the heart decreases over time, and will eventually reach asystole.

AED has been widely used in developed countries. The United States of America began introducing a public defibrillation system in 1995, under the guidance of the American Heart Association (AHA). In 1999, in public places such as large shopping malls, airports, train stations, and leisure sites, the British government also developed external defibrillation policies. Most well-known medical device firms, such as Philips, GE, Zoll and Medtronic, have their own AED devices. AED research in India is still in its initial phase, however, and clinical applications did not have an external defibrillator in the home.

An AED is "automatic" because of the device's capacity to autonomously evaluate the patient's condition. The vast majority of units have been speaking prompts to help with this and others may also have visual signals to warn the user. "External" means that the operator applies the electrode pads to a bare chest of the victim.

Upon turning on or opening the AED will advise the user to attach the electrodes (pads) to the patient. If the pads are mounted, each will avoid touching the patient to avoid having false readings of the device. The pads allow the AED to examine the electrical output of the heart and determine whether the patient is at a shockable rhythm (both ventricular fibrillation and ventricular tachycardia). Once the device determines that a shock is required, the battery will be used to charge its internal condenser in preparation for the shock delivery. Not only is the device system safer-charging when necessary, it also allows faster delivery of electric current. Human involvement is normally needed to give the patient the shock to prevent the risk of an accidental injury to another person.

1.1 Literature Review

In [1], The paper basically speaks about the importance of Automated External Defibrillators as an immediate clinical assistance for SCA patients. The most effective way to treat a SCA is with defibrillation, namely a therapeutic dose of electrical energy. The necessity of performing defibrillation within a few minutes of SCA has led to the development of AEDs: their timely use can improve outcome after SCA. For this reason, AEDs have been designed to be used with little or no medical knowledge allowing the widespread distribution of these devices for reducing SCA victims. AEDs should be present in public places with the highest probability to have SCA events, such as public transportation areas (train stations or airports), shopping malls, schools and colleges, working areas etc.

In paper [2], untrained laypersons can use semi-automated AEDs sufficiently quickly and with minimal instructions. The observation that measures of practical performance (i.e. time to first shock, accuracy of electrode pad placement and safety) were significantly improved after minimal theoretical instruction, but without technical instruction in the use of the device. One of the most remarkable findings is that all tested laypersons were able to deliver a shock in less than 1 min after minimal instructions had been given, regardless of whether automatic or semiautomatic mode was used. Finally, the paper concludes that only minimal background knowledge is needed for laypersons to use an AED safely and quickly, and that further implementation of AEDs for use by minimally trained persons without any medical training is possible.

In paper [3], Use of automated external defibrillators (AEDs) by first arriving emergency medical technicians (EMTs) is advocated to improve the outcome for out-of-hospital ventricular fibrillation (VF).

In paper [4], in order to make the actual energy of defibrillation approximate to target defibrillation energy in automated external defibrillator, an energy compensation method is used. This is undoubtedly a real blessing for medical instruments, in pursuit of safety and stability. The research on energy compensation of defibrillators has made a considerable achievement, but energy compensation still has big space for improvement, and further research needs to be continued.

In paper [5], the paper presents a novel compositive algorithm by merging a slope variability analyser with a band-pass digital filter to accurately distinguish shockable rhythms from non-shockable rhythms for automatic external defibrillators.

2. Methodology

A defibrillator is a machine that sends a high energy electric shock through the heart. This high energy electric shock is called defibrillation. The aim of this shock is to return a heart to its normal working state if it goes into cardiac arrest.

If an individual is showing signs of a cardiac arrest, a defibrillator can be used to return their heart to its normal rhythm. A cardiac arrest is when the heart suddenly stops pumping blood around the body, usually due to a problem with the heart's electrical signals. If the heart stops pumping blood around the body, the brain will be starved of oxygen and this will result in a person losing consciousness and stopping breathing.

A cardiac arrest is considered a medical emergency and immediate action needs to be taken, otherwise it could be fatal. If someone is in cardiac arrest, they will be unconscious, unresponsive and they won't be breathing, or they won't be breathing normally. In such cases emergency treatment includes Cardiopulmonary Resuscitation (CPR) and defibrillation. Pressing on the chest can cause a sore chest, broken ribs or a collapsed lung. CPR may not be able to restart your heart. Hence we go for defibrillators.

The flowchart below describes the mechanism of Defibrillation:

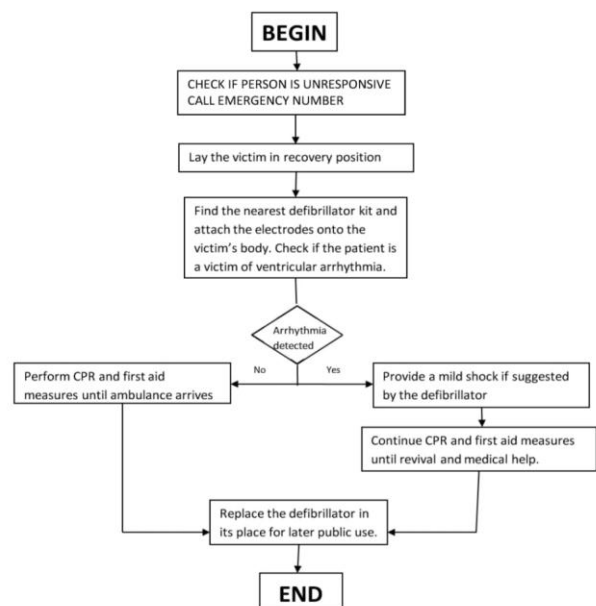

Figure 1. Flowchart of Mechanism of Defibrillation.

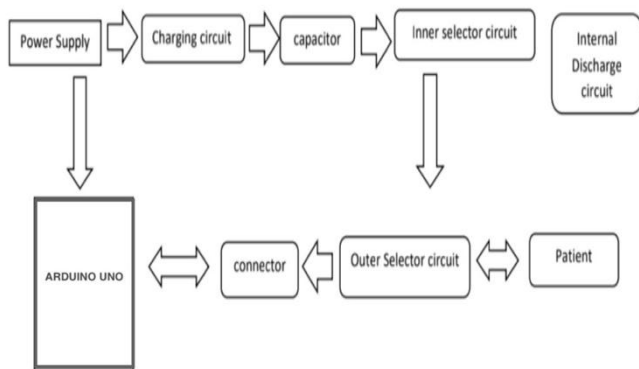

Figure 2. Block Diagram of Semi-automated defibrillator.

Working of Defibrillator circuit:

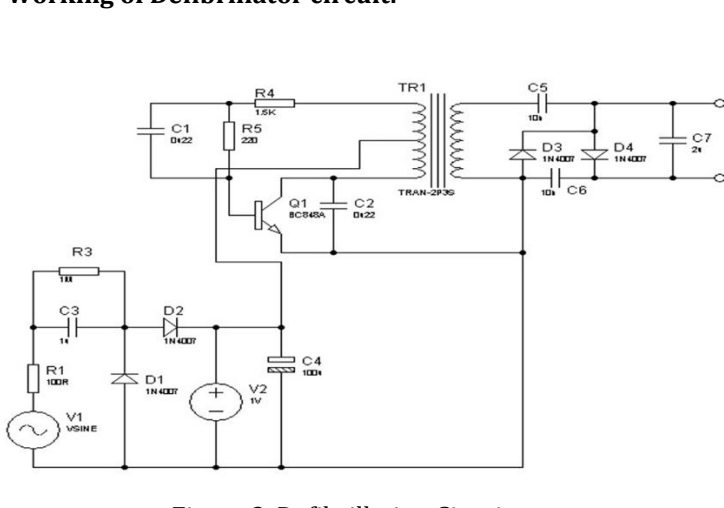

Figure 3. Defibrillation Circuit

Referring to the figure alongside we see that the circuit is basically made up of three stages viz. the power supply stage, the oscillator stage and the voltage booster stage.

- **Power supply stage:** This part consists of three components the Transformer, the Bridge Rectifier, and the Filter Capacitor. The Transformer is used to step down the applied AC mains through electromagnetic induction. But this voltage is still a low voltage AC and requires rectification and filtration. Rectification is done by the bridge rectifier (comprised of 4 rectifier diodes) and this rectified voltage is further filtered by the preceding electrolytic filter capacitor to produce a clean DC at the output. The winding inside the coil is calculated for working with 3V DC supply, meaning the circuit becomes compatible with a 3V battery pack made by putting a couple of cells in series. When power is applied to the circuit, the transistor and the centre tapped transformer instantly start oscillating at the specified high frequency. This forces the battery current to pass across the TR1 winding in a push pull manner.

Switching operation generates a proportional induced high voltage across the secondary winding of TR1., this voltage could be somewhere around 200V.

- **Oscillator stage:** Oscillator: An oscillator converts the input DC (Direct Current) into an oscillating current or a square wave which is fed to the secondary winding of a power transformer. In the present circuit Blocking oscillator circuit concept is used, A blocking oscillator is one of the simplest form of oscillators which is able to produce self-sustaining oscillations through the use of just a few passive and a single active component. The name "blocking" is applied due to fact that the switching of the main device in the form of a BJT is blocked (cut-of) more often than it's allowed to conduct during the course of the oscillations, and hence the name blocking oscillator. R1 along with the preset and the C1 determine the frequency of oscillation. R1 ensures that the transistor never comes within an unsafe zone while adjusting the preset.
- **Voltage booster stage:** To further enhance and lift this voltage to a level which may become suitable for generating a spark, a charge pump circuit involving a Crockcroft-Walton ladder network is used at the output of TR1. This network pulls the 200V from the transformer to about 600V. This high voltage is rectified and applied across a bridge rectifier where the voltage is appropriately rectified and stepped up by the 2uF/1KV capacitor.

As long as the output terminals across the 2uF capacitor are held at some specified distance, the stored high voltage energy inside the capacitor is unable to discharge, and stays in a standby condition.

If the terminals are brought at a relatively closer distance (about a couple of mms) the potential energy across the 2uF capacitor becomes capable enough to break the air barrier and arc across the terminal gap in the form of a flying spark.

Once this happens, the arcing momentarily stops, until the capacitor charges fully to execute another spark, and the cycle keeps repeating as long as the gap distance is kept within the saturable distance of the high voltage.

The circuit also includes a small charger circuit which may be connected to mains for charging the 3V rechargeable battery when the bat stops generating sufficient arcing voltage while giving shock.

3. RESULTS AND FUTURE SCOPE:

The focus of the project is mainly on the detection of Ventricular fibrillation of the heart and provide a therapeutic amount of electric current and depolarize a large amount of the heart muscle, which subsequently ends arrhythmia.

The algorithms were tested in Matlab on pre-available data set of pathological ECG signals obtained from Physio net. In addition, also some signals obtained directly using the receptor paddles were used to additionally validate their specificity.

The resulting graph from the software shows the ECG of the victim and the heading of the plot specifies if the victim's ECG is normal or affected by a cardiac arrest. Also, the continued output shows that the variable y which detects abnormalities in the ECG shows 0 or nearly 0 if there exists irregular rhythms/ventricular fibrillation else it shows 1 for a normal heart rhythm.

One may observe through the hardware that a mild shock is produced in the case of detection on a cardiac arrest by designing codes compatible with Arduino UNO which retrieves signals by means of receptor paddles placed on the victim's body. Therefore, the software code should be designed in order to recognise the presence of artefacts, or at least minimize their effects to avoid erroneous decisions.

Hence, a future version of Off-Hospital AED may swap this algorithm for a more efficient one.

How effective are AEDs?

Extremely effective—especially compared with CPR without it. Depending on which statistics you read and whether the person receiving treatment is in a hospital or not, CPR is only 2%-18% effective. AEDs, by contrast, increase survival rates for victims of sudden cardiac arrest by more than 80% if the person receives treatment within the first three minutes.

Perhaps this is because ventricular fibrillation, a particularly deadly form of heart arrhythmia, is at the root of almost 90% of instances of cardiac arrests in adults. The only way to halt ventricular fibrillation is by using a defibrillator.

It's not hard to use an AED—even for people with no prior medical training. If you own or work at a facility with an AED present, or anywhere someone might experience cardiac arrest, it is absolutely worth it to have an AED on the premises as well as people who know how to use one. AEDs are most effective within the first three minutes of a cardiac arrest—and it can take longer than that for bystanders to realize something is wrong and to call an ambulance. In addition, AEDs improve recovery statistics for cardiac arrest victims from as low as 2% to upwards of

80%. There's no question that AEDs save lives—and knowing how to use one is a useful skill.

Social impact of AED on survival rates

An international group of researchers has discovered that those suffering from cardiac arrest in a public setting are twice as likely to survive if an automated external defibrillator (AED) was utilized before emergency help arrived.

It is estimated that about 1,700 lives are saved in the around the world per year by using an AED. Fewer than half (45.7 percent) of cardiac arrest victims get the immediate help they need before emergency responders arrive, in part because emergency medical services take, on average, between four and 10 minutes to reach someone in cardiac arrest, according to the AHA.

Impact of AED on human health

During a cardiac arrest, the electrical activity in the heart is disrupted. Without immediate CPR, the heart, brain and other vital organs aren't receiving enough oxygenated blood. For every minute without CPR, the chance of death increases by 10 percent, according to the AHA.

Sixty-six percent of victims who received a shock from AED survived to hospital discharge. The research stressed the critical difference in those who received cardiac care before responders arrived on the scene.

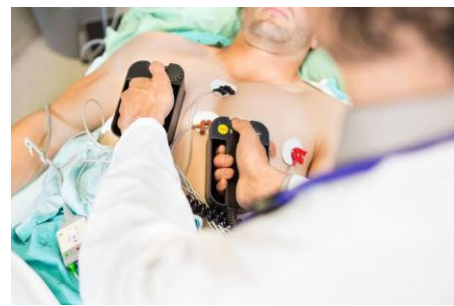

Figure.4. Therapeutic shock from Defibrillators

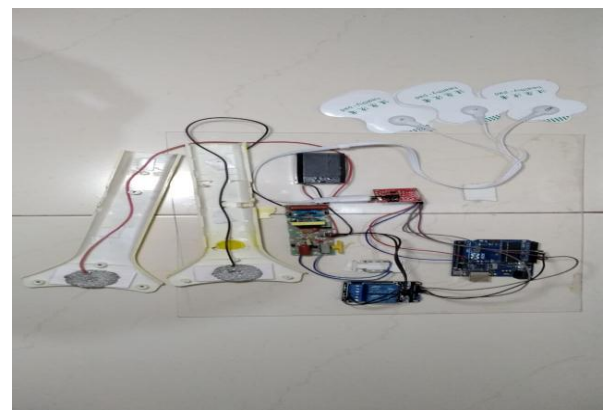

Figure.5. Defibrillator prototype

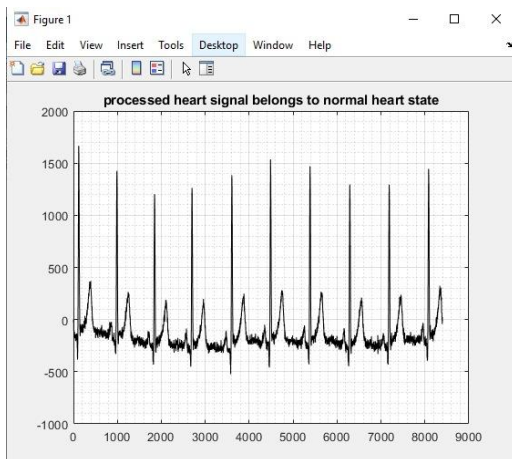

Figure.6. Detection of Abnormal ECG

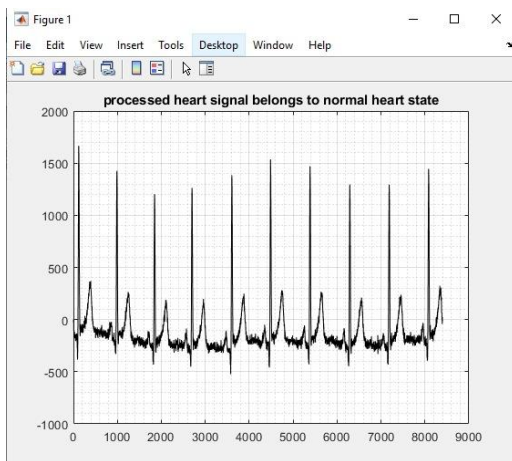

Figure.7. Detection of Normal ECG

4. CONCLUSIONS

The defibrillator is currently recommended as the best resuscitation technique which can be widely used by any layperson to deliver a shock manually. It has been shown to decrease mortality rates and neurological deficits of victims of out-of-hospital cardiac arrests.

The proposed design of defibrillator is a powerful therapeutic tool. The advancements are making the defibrillators easier to use, cost effective and user convenient for public usage.

The implementation of AED programs is a sustainable and culturally acceptable measure, bringing an undeniable benefit to society and public health

REFERENCES

[1] Jacopo Ferretti¹, Licia Di Pietro², Carmelo De Maria³ "Open Source Automated External Defibrillator", volume 2, Hardware article, ELSEVIER, october 2017.

[2] Beckers S, Fries M, Bickenbach J, Derwall M, Kuhlen R, Rossaint R: "Minimal instructions improve the

performance of laypersons in the use of semiautomatic and automatic external defibrillators" Crit Care 2005, 9:R110-R116.

[3] Cobb LA, Fahrenbruch CE, Walsh TR, Copass MK, Olsufka M, Breskin M, Hallstrom AP: "Influence of cardiopulmonary resuscitation prior to defibrillation in patients with out-of-hospital ventricular fibrillation." JAMA 1999, 281:1182-1188.

[4] Yang Shengjun Ge Xin Wang Xu Wu Xiaomei Fang Zuxiang, Department of Electronic Engineering, Fudan University, Shanghai, 200433, China "Study on energy compensation in automated external defibrillator" . IEEE paper -June 2011.

[5] Fei Zhang, Pengye Li, Fan Jiang and Dakun Lai School of physical Electronics University of Electronic Science and Technology of China Chengdu, China, 610054 "A Shockable Rhythm Detection Algorithm for Automatic External Defibrillators by Combining a Slope Variability Analyser with a Band-Pass Digital Filter" -IEEE paper 2017.

[6] Joshua Kovach • Stuart Berger "Automated External Defibrillators and Secondary Prevention of Sudden Cardiac Death Among Children and Adolescents" - IEEE paper february 2012.

[7] Sreeram Dhurjarty and Aniruddha atre Dhurjarty Electronics consulting LLC -"A Hand-Cranked, Affordable Defibrillator for Resource Settings."-IEEE Conference paper 2018.

[8] Shah,Sandy N, "Defibrillation and cardioversion, Medscape", April 14,2016 <http://emedicine.medscape.com/article/80564-overview>

[9] P. Calle • N. Mpotos -"Why not try harder to prove that automated external defibrillators save lives?"-Neth Heart J 28th february 2019.

[10] A. Parameswaran, S.J. Patel, R.V. Darji, A. Sorgi New Jersey Institute of Technology 323 Martin Luther King, Jr. Boulevard University Heights Newark, New Jersey 07102 - "Designing an Acoustics-Powered Automated External Defibrillator Battery Charge"-IEEE Conference paper 2012.

[11] JANICE L JONES, MEMBER, IEEE, AND OSCAR H. TOVAR, MEMBER, IEEE - "A Mechanism of Defibrillation and Cardioversion" IEEE paper 1996.

[12] Richard C. Hunt, MD, FACEP Department of Emergency Medicine East Carolina University School of Medicine Greenville, North Carolina 27858-4354 - "AUTOMATIC DEFIBRILLATION FOR LAYPERSONS".

IEEE TRANSACTION ON BROADCASTING, Vol.38. NO 2, June 1992.

- [13] Paula Willoughby DeJesus Assistant Professor of Medicine, Department of Medicine, Section of Emergency Medicine, University of Chicago, Illinois, USA "Charging up the public for automated external defibrillators." – CCFORUM ,24th Feb. 2005.
- [14] Caffrey S, Willoughby PJ, Pepe P, Becker L: "Public use of automated external defibrillators". N Engl J Med 2002, 347:1242- 1247.
- [15] Myron Kostiv "Problems of introduction of automated external defibrillators for application in Ukraine. Defibrillator is one of the most advanced radio electronic medical device allowing considerable reduction of deaths caused by ventricular defibrillation." IEEE Conference paper 2010.
- [16] F.M Charbonnier "External defibrillators and emergency external pacemakers" IEEE Journal Article volume:84 1996.
- [17] Vessela Krasteva, Sarah Menetre, Irena Jekova, Todor Stoyanov, Daniel Jost, Benoit Frattini, "Comparison of Pediatric and Adult ECG rhythm Analysis by Automated External Defibrillators during Out-of-Hospital Cardiac Arrest" IEEE Conference paper volume: 45 2018.
- [18] Raymond Bond, Peter O'Hare, Rebecca Di Maio "Usability testing of a novel automated external defibrillator user interface" IEEE Conference paper 2015.
- [19] Munna Khan, Ajai Kumar singh, Bharat Bhushan Sharma "Solar power automated external defibrillators in remote areas: A computer simulation" IEEE Conference paper 2014.
- [20] Philips Defibrillator Heart start XL. <https://www.davismedical.com/usedphilips-heartstart-xl-defibrillator.aspx> [Accessed 08.06.2018]