

Miniature Water Purifier based on IoT

Vasudev Upadhyaya K S¹, Tejas P², Vignesh Kumar V³, Praveen Tulsidas Naik⁴, Praveen A⁵

¹⁻⁴Student, Dept. of Electronics and Communication Engineering, KSIT, Karnataka, India

⁵Asst. Professor, Dept. of Electronics and Communication Engineering, KSIT, Karnataka, India

Abstract - Water pollution and contamination of water is major problem across the globe. The water bodies are polluted by human activities. The solution for contamination of water is to purify the water and monitoring the purity of the water. Total dissolved solids sensor (TDS) is used in the water purifier to measure the TDS value of the water, to reflect the purity of the water. TDS value continuously measured if the value goes below the predefined value, then the message will be sent to the user to alert him about the less purity in the water using the Internet of things (IOT) technology. Temperature sensor is used in this purifier to measure the temperature of purified water. The parts per million (ppm) value obtained from TDS sensor will change if there is huge change in temperature and water flow sensor which will sense the rate of flow of water and quantity of the water purified. The information regarding temperature ppm value and rate and flow of the water purified will be shown on the Liquid crystal display (LCD) display and the information is also sent to the user through mobile applications.

1. INTRODUCTION

The water resources in the world are polluted by the human activities. These human activities involves dumping chemical waste from the industries to the river and lakes. Many factors like increase in population, dumping of industrial waste, oil leakage, are responsible for pollution of the water. The earth water resources are oceans, seas, rivers, ground water, ice caps, glacier etc. Water pollution means contamination of water bodies. The contaminants such as fertilizer, pesticides used by the farmers to protect the crops by the insects and bacteria's pollutes the ground water. Water purification is the process of removal of undesirable chemicals, biological contaminants, suspended solids and gases from water. Oil leakage by accident is huge threat to the oceans and marine life. Drinking tap water or impure water causes cholera, dysentery, typhoid, diarrhea and polio. The presence of pollutants in the water causes diseases like arsenicosis due to arsenic and fluorides components in the water. The process of removal of suspended particles, microbes, undesirable chemicals is called water purification. The Major process of water purification involves sediment filter which removes suspended particles and sand particles from the water. carbon filter is used to remove bad odour and colouring substance from the water. The next stage is UF filtration which purifies smaller impurities, bacteria and colloidal

matters. The process is similar to reverse osmosis, but large pores are used in the membrane. No electricity is required for UF filtration, it can work on normal water pressure. The Ultrafiltration (UF) remove most of the contamination and microbes from the water. This system consists of Temperature sensor, water flow sensor and TDS module. TDS sensor continuously measure the TDS value of the water and sends the message to the user using ESP32 Wi-Fi module. Temperature sensor is used in the system to measure the temperature of the water because as the temperature varies the ppm value obtained by the TDS sensor also varies. This system contains a water flow sensor which helps to determine the amount of water purified.

2. Literature survey

[1] In the paper "Water quality monitoring for rural areas -A sensor cloud based economical project ." published in 2015. depicts the supervision of water quality based on many technique such as, sensors operation, embedded design, and information dissipation procedure regarding the monitoring control and role played by the government in monitoring the water quality, network operation and conveying correct information to the villagers. Systematic use of technology and economic practices is necessary to enhance purity of water and consciousness among the people.

[2] In the paper "Real time water quality monitoring systems". illustrates about monitoring of quality of water based on real time applications and it helps to secure the safe supply of drinking water. The design of IOT based water quality monitoring system that design of IOT based water quality monitoring system that check the quality of water continuously in real time. This system contains many sensors which measures the parameters related to the quality of the water such as TDS value, turbidity, PH, dissolved oxygen and temperature.

This measured sensor values are sent to the microcontroller. Microcontroller processes these value and transmitted remotely to raspberry pi using ZigBee protocol. Cloud computing helps to view this sensor values on the internet.

[3] In the paper "Industry4.0asa Part of Smart Cities". author", proposed the concept of Industry 4.0, the Internet of Things (IoT) shall be used for the

development of so-called smart products.

Subcomponents of product are equipped with their own intelligence. Added intelligence is used both during the manufacturing of a product as well as during subsequent handling, upto continuous monitoring of the product lifecycle (smart processes). Other important aspects of the Industry 4.0 are Internet of Services (IoS), which includes especially intelligent transport and logistics (smart mobility, smart logistics), as well as Internet of Energy (IoE), which determines how the natural resources are used in proper way (electricity, water, oil, etc.). IoT, IoS, IoP and IoE can be considered as an element that can create a connection of the Smart City Initiative and Industry 4.0 – Industry 4.0 can be seen as a part of smart cities .

[4] In the paper “QOI-Aware Energy Management in Internet-of- Things Sensory Environments”. An efficient energy management frame work to provide satisfactory QOI experience in IOT sensory environments is studied. Contrary to past efforts, it is transparent and compatible to lower protocols in use, and preserving energy-efficiency in the long run without sacrificing any attained QOI levels. Specifically, the new concept of QOI-aware “sensor-to-task relevancy” to explicitly consider the sensing capabilities offered by an sensor to the IOT sensory environments, and QOI requirements required by a task. A novel concept of the “critical covering set” of any given task in selecting the sensors to service a task over time. Energy management decision is made dynamically at runtime, as the optimum for long-term traffic statistics under the constraint of the service delay. Finally, an extensive case study based on utilizing the sensor networks to perform water level monitoring is given to demonstrate the ideas and algorithms proposed in this paper, and a simulation is made to show the performance of the proposed algorithms.

[5] In the paper “Adaptive edge analytics for distributed networked control of water systems” Explains the water distribution networks using the burst detection and localization scheme with the light weight compaction and spotting with graph topology. The amount of communication between the sensors and backend servers can be reduced, but can successfully constrain water flow using different arrival times detected at the sensor location by this approach. This results can save up to 90% communications compared with conventional periodical reporting situations.

The filtration membranes are classified based on their size of pores in μm , UF membrane pore size ranges from 0.1 to 0.001microns. UF membrane removes higher molecular weight whose size are more the membrane pore. To separate particles of molecular weight between 1 to 300Kda and suspended particles

greater than 300Kda pressure is applied greater than 1Mpa. Due to which particles of molecular weight of 1 to 300kda is passed through the membrane other particles are retained.

The application of UF filtration are purification of food substance, beverages and extraction of proteins from food materials and pharmaceutical industries[7],[8],[9]. UF filtration helps to remove toxic metal Concentration and harvesting of cells or liposome in biotechnology [10], [11], [12], blood dialysis, recycling of waste water to produce potable water [13],[14],[15].

3. Proposed system

This IOT based miniature water purifier is basically divided into two units that are interfaced with each other these units helps to provide clear view on the device. These sections are:

1. Filtering unit
2. Active sensing unit

Filtration unit: The important unit in the purifier is the filtration unit. It plays a major role in the purification of water. It involves a series of process water filtration. The main purpose is to eradicate the suspended particles, biological contaminants, gases from the water so that it can be made suitable for drinking. In this project the process namely, reverse osmosis is being used for water filtration. It is the process in which the pressure is applied to the water so that the solute remains on one side of the membrane and the pure water is collected on the other side.

Active sensing: In this section three types of sensors are used. These sensors are TDS sensor, Temperature sensor. TDS sensor consists of TDS meter inbuilt in it. This continuously monitors the quality of the purified water at the output of purifier. It will do nothing if the TDS value of water remains above the predefined value. If the value of total dissolved solids goes below the level the TDS sensor will generate a signal and will send this signal to system. After receiving the active signal the system will generate a message. This message will be sent to the persons whose numbers will be given to the module. Basically it will send a message to retailer as well as to the user. Another sensor is temperature sensor which will continually monitor the temperature of the water. This information will be shown using the LCD. Another sensor is water flow sensor which is determine the rate and amount of water purified by the purifier.

The major and the important block of the miniature water purifier is the sensors block and the control section of the purifier. The purifier consists of various hardware components and software modules for its. It consists of following components/ parts which are given as:

1. Microcontroller ESP32
2. TDS module
3. water flow sensor
4. LCD
5. power supply
6. Temperature Sensor

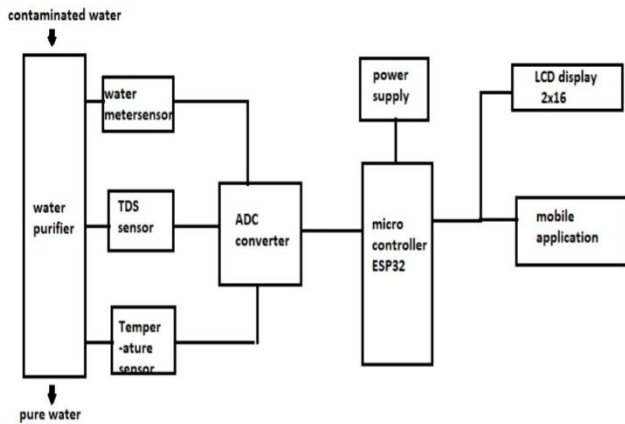

Fig1: Block diagram of water Purifier

Descriptions of components

A. Microcontroller (ESP 32)

ESP32 is a single 2.4 GHz Wi-Fi-and-Bluetooth combo chip designed with the TSMC ultra-low-power 40 nm technology. It is designed to achieve the best power and RF performance, showing robustness, versatility and reliability in a wide variety of applications and power scenarios. ESP32 is designed for mobile, wearable electronics, and Internet-of-Things (IoT) applications. ESP32 is a highly-integrated solution for Wi-Fi-and-Bluetooth IoT applications, with around 20 external components. ESP32 integrates an antenna switch, RF, power amplifier, low-noise receive amplifier, filters, and power management modules. As such, the entire solution occupies minimal Printed Circuit Board (PCB) area.

B. TDS sensor

It indicates the amount of total dissolved particles in water. Dissolved particles can ionized solids such as salts and minerals or colloids. These particles can adversely affect our health if they are present in amount greater than required. This sensor indicates the concentration of dissolved solids on display in ppm(parts per million). When it senses the amount of total dissolved solids in water is not suitable for drinking it generates an analog signal which is fed to microcontroller via ADC (converts the analog signal to digital signal).

C. 16x2 LCD display

Liquid Crystal Display also called as LCD is very helpful in providing user interface as well as for debugging purpose. The most common type of LCD controller is HITACHI 44780 which provides a simple interface between the controller & an LCD. These LCD's are very simple to interface with the controller as well as are cost effective. The LCD requires 3 control lines (RS, R/W & EN) & 8 (or 4) data lines. The number on data lines depends on the mode of operation. If operated in 8-bit mode then 8 data lines + 3 control lines i.e. total 11 lines are required. And if operated in 4-bit mode then 4 data lines + 3 control lines i.e. 7 lines are required. How do we decide which mode to use? It's simple if you have sufficient data lines you can go for 8 bit mode & if there is a time constrain i.e. display should be faster then we have to use 8-bit mode because basically 4-bit mode takes twice as more time as compared to 8-bit mode.

D. Water flow sensor

Water flow sensor consists of a plastic valve body, a water rotor, and a hall-effect sensor. When water flows through the rotor, rotor rolls. Its speed changes with different rate of flow. The hall-effect sensor outputs the corresponding pulse Signal. One of the most common ways to measure liquid flow rate is exactly like the principle of measuring the speed of wind by an anemometer: the speed of wind is proportional to the rotation speed of the anemometer. The main part of this type of flow sensor is a sort of a pinwheel, whose speed is proportional to the liquid flow rate passing through it.

E. Temperature sensor (DS18B20):

The DS18B20 Stainless Steel Temperature Sensor is a pre-wired and waterproofed version of the DS18B20 sensor. Its unique 1-wire interface makes it easy to communicate with devices. It can convert temperature to a 12-bit digital word in 750ms(max). This Maxim-made item is a digital thermo probe or sensor that employs DALLAS DS18B20. Its unique 1-wire interface makes it easy to communicate with devices. It can convert temperature to a 12-bit digital word in 750ms (max). Besides, it can measure temperatures from -55°C to +125°C (-67F to +257F). In addition, this thermo probe doesn't require any external power supply since it draws power from data line. Last but not least, like other common thermo probe, its stainless steel probe head makes it suitable for any wet or harsh environment.

F. Power supply

This unit provides the power supply to the system. Basically the power supply unit converts the AC voltage of high value to low value in dc voltage. In this project we use 5V supply for the controller section and SMPS for the filter section.

4. Results

Microcontroller ESP32 is the latest microcontroller in the market . It is major building block of the water purifier system. It provides the major control to the device and acts as a control unit to the purifier device. Sensors also plays a major role in the device .Mainly we are using three sensors which helps to provide the accurate reading of the purified water. We also we various filters for the sake of purification of the water. Carbon filter ,sediment filter and ultra filtration is used in purification section which helps to purify the water .This filters helps to remove the dirt particles,debris particles and minute waste particles present in water the carbon filter helps to remove the colour and odour of impure water . TDS sensor, temperature sensor and water flows sensor are used to measure the accurate values of water's PPM values , these PPM values helps us to detect purity of the water .The impure water flows through the following filters . These filters remove the waste and impure substances from the water at each individual stages .The water flowing through the filters is purified and obtained at the other end of the purifier .the temperature sensor helps to determine the temperature of the water . The water flow sensor monitors the rate and volume of water purified . The TDS sensor helps to measure the PPM value of the water ,it indicates the purity of the water .These are controlled by the microcontroller and the data regarding the purity, water flow rate and temperature is continuously sent to the user using the Wi-Fi based on the suitable mobile application.



Fig2: sensor interface



Fig3: Display of TDS and Temperature value



Fig4: Display of flow rate values

5. Conclusion

This paper explains briefly about water purification system with smart water quality monitoring using IOT technology. Monitoring of temperature, TDS value, and rate off low of water by using water detection sensor with advantages and applications with existing IOT technology. By using this water purification system, the user can monitor the water quality without human intervention.

References

- 1) Nikhil Kedia, Water Quality Monitoring for Rural Areas- A Sensor Cloud Based Economical Project, in 1st International Conference on Next Generation Computing Technologies (NGCT-2015) Dehradun, India, 4-5 September 2015. 978-1-4673-6809-4/15/\$31.00 ©2015 IEEE.
- 2) Jayti Bhatt, Jignesh Patoliya, IoT Based Water Quality Monitoring System, IRFIC, 21feb, 2016.
- 3) Michal lom, ondrej priby & miroslav svitek, Internet 4.0 as a part of smart cities, 978-1-5090-1116-2/16/\$31.00 ©2016 IEEE
- 4) Zhanwei Sun, Chi Harold Liu, Chatschik Bisdikia, Joel W. Branch and Bo Yang, 2012 9th Annual IEEE Communications Society Conference on Sensor, Mesh and Ad Hoc Communications and Networks
- 5) Sokratis Kartakis, Weiren Yu, Reza Akhavan, and Julie A. McCann, 2016 IEEE First International Conference on Internet-of-Things Design and Implementation, 978-1-4673-9948-7/16 © 2016IEEE
- 6) C. de Morais Coutinho, M. C. Chiu, R. C. Basso, A. P. B. Ribeiro, L. A. G. Gonçalves, and L. A. Viotto, "State of art of the application of membrane technology to vegetable oils: A review," Food Research International, vol. 42, no. 5-6, pp. 536-550, Jun. 2009.
- 7) W. H. Howard and R. Lambert, "Ultrafiltration in the Ontario Dairy Industry," Canadian Journal of Agricultural Economics, vol. 41, no. 2, pp. 177-195, 1993.

- 8) K. L. Jones and C. R. O'Melia, "Ultrafiltration of protein and humic substances: effect of solution chemistry on fouling and flux decline," *Journal of Membrane Science*, vol. 193, no. 2, pp. 163–173, 2001.
- 9) Hinkova, Z. Bubnik, V. Pour, S. Henke, and P. Kadlec, "Application of cross-flow ultrafiltration on inorganic membranes in purification of food materials," *Czech Journal Of Food Sciences*, vol. 23, no. 3, pp. 103–110, 2005.
- 10) R. S. Tutunjian, "Ultrafiltration processes in biotechnology.," *Annals Of The New York Academy Of Sciences*, vol. 413, pp. 238–253, 1983.
- 11) R. Ghosh and Z. F Cui, "Purification of lysozyme using ultrafiltration.," *Biotechnology and Bioengineering*, vol. 68, no. 2, pp. 191–203, 2000.
- 12) R. Magin and H.-C. Chan, "Rapid separation of liposomes using ultrafiltration," *Biotechnology Techniques*, vol. 1, no. 3, pp. 185–188, 1987.
- 13) E. R. Christensen and K. W. Plaumann, "Waste Reuse: Ultrafiltration of Industrial and Municipal Wastewaters," *Journal Water Pollution Control Federation*, vol. 53, no. 7, pp. pp. 1206–1212, 1981.
- 14) D. Revchuk and I. H. M. Suffet, "Ultrafiltration separation of aquatic natural organic matter: chemical probes for quality assurance.," *Water Research*, vol. 43, no. 15, pp. 3685–3692, 2009.
- 15) W. J. Koros, Y. H. Ma, and T. Shimidzu, "Terminology for membranes and membrane processes (IUPAC Recommendations 1996)," *Pure and Applied Chemistry*, vol. 68, no. 7, pp. 1479–1489, 1996.