

# IoT based Design of Wireless Sensor Network Node for Forest Trees against Poaching

Ramesha T<sup>1</sup>, H M Shamita<sup>2</sup>

<sup>1</sup>IV SEM M.Tech (DEC), Dept. Of Electronics & Communication Engg. PDIT, Hosapete, Karnataka, India

<sup>2</sup>Associate Professor, Dept. Of Electronics & Communication Engg. PDIT, Hosapete, Karnataka, India

\*\*\*

**Abstract** - We commonly read in the Newspaper about the poaching of the Trees in forest such as Red and white Sandalwood trees, Mahogany, Malabar neem, Burma teak and CP teak etc taking place across the globe. Since the purpose of these trees are more, and also the cost of those trees is also huge. By selling the woods of such trees, a large amount can be earned and therefore the smuggling of such trees may take place which is considered to be an illegal act and also affects the growth of the country. In order to prevent the illegal smuggling of these trees some necessary measures are to be undertaken. The goal is to design a system which restrict the smuggling and save these valuable trees so that eco-system is under balanced state by preventing deforestation. The system uses the WI-FI module and android application from which we can find the location of the tree where the poaching is done. The system also uses a chip (board) on which various Wireless sensor devices (such as sound sensor, vibration sensor, metal detector and Temperature/Humidity Sensor) are embedded and which are controlled through IoT. These sensors monitors and controls the parameters like tilting, burning and cutting of the trees, and these are continuously updated on Blynk Android App installed in Smart phone.

**Key Words:** Arduino UNO controller, DHT11 sensor, Wi-Fi module, Sound sensor, Metal detector, vibration sensor, Blynk server (cloud) and smart phone (installed with blynk app)

## 1. INTRODUCTION

In the newspapers daily we read about poaching of the trees like red or white sandalwood, bermua teak Sagwan, Khair trees etc. Poaching of trees not only finds with India, but also China, Australia, and South African countries are also facing same problem. These trees are used in clinical sciences just as beautifier's. These trees are very costly and their availability is limited across the world. The main reason behind cutting or smuggling of trees incidents are happening due to their selling cost is very high. The current price of the sandalwood is 12000 to 13000 INR per kg+ tax in India [1] though in global market the cost of the Red Sandals is 10 crore INR per every ton. The sandalwood tree has turned out in recent years; attempting to control its possible incident the Indian government is endeavoring to limit transship of sandal [2]. For an individual, most extreme allowable buy limit is not to cross 3.8kg according to Govt. If tree is under government control, as per the govt. rule tree removal is prohibited even on sanctum or infantry grounds until the age of the tree must attain 30years. Poaching of sandal has created economic and peace problems in territories of India. The goal is to implement a system which effectively prevents poaching of valuable trees in the forest.

- A handy and portable wireless sensor network node is designed and it has to be placed on tree trunk, which is able to find the smuggling of trees or any natural disaster events and also update the alert message to the forester (Blynk app is installed with smart phone user) automatically.
- By reducing power consumption of controller, we can increase the performance of the WSN node which exceptionally saves battery life.
- To avoid false detection of illegal logging of trees, we have to analyze all the installed sensor results and take necessary action in real time.
- With the help temperature sensor unit we can easily locate the affected forest area when natural disasters like earthquake, storms, hurricanes and other geological processes occurs and also to take necessary actions.

## 2. LITERATURE SURVEY

In many papers which I surveyed, most of the systems use low speed controller and less efficiency devices to monitor different environmental conditions and illegal logging of trees at forest in real time process. It's very important to measure the variables such as temperature, tilting, humidity, sound intensity fluctuate with time in certain applications and hence these changes must be observed and to be recorded. We can take necessary control action by analyzing those recorded data.

Many of the system propose to utilize a low speed controller embedded system for a temperature sensor hub having a system interface utilized wireless technology 802.15.4 Zigbee protocol. It is a technical standard defines the operation of low-power wireless personal area networks and used here for addressing low-cost, low-power wireless sensor networks. The temperature sensor node senses and updates the variations in the temperature level to the controller placed nearby it and also sent to android app via Wi-Fi module. Similarly all other sensors senses the conditions and sent to the base station

- In the year 2016-17, the DRI team of Chennai had seized more than 50metric tones of red sanders.
- 2017-18, the DRI seized 40metric tonnes of red sanders worth about 16 crores at punrutti, near Chennai.
- At Berhampur, endangered red sandalwood seized from the smugglers.
- Plan to check interstate sneaking of timberland woods.- The Times of India, Ahmadabad.
- In UP, nearly 200 teak trees are cut, timber poached.
- In AP, according official statistics nearly 75 red sanders cases are registered in 2019 and seized value fell to 16.45 crore from 74.40 crore in 2018.

### 3. PROPOSED SYSTEM

The idea is to develop a system in such a way that which must be portable, compact, and easy to access. Our proposed system has wireless sensor network node i.e. bunch of different sensor, processing unit and android Smartphone to save the most valuable trees in forest against poaching. This design involves wireless sensor node, microcontroller and IOT module is equipped at trunk of the tree. Android phone with Blynk app is used at the receiver to collect the data. The Blynk application will continuously receive sensor data. Sensor data is continuously sent to cloud (Blynk server) over a Wi-Fi module. When vibration or tilt sensor detects the fallen of tree or bending more than threshold and the buzzer turn on. If temperature sensor detects fire or high temperature (more than threshold) water pump is turned on through relay switch. According to this proposed design, each tree is attached with individual node has a set of wireless sensor; master sensor node is a sensor node with additional battery power for communicate with base station. Master sensor node will receive all the data from the adjacent secondary nodes and sent via Wi-Fi module to the forest officials or user.

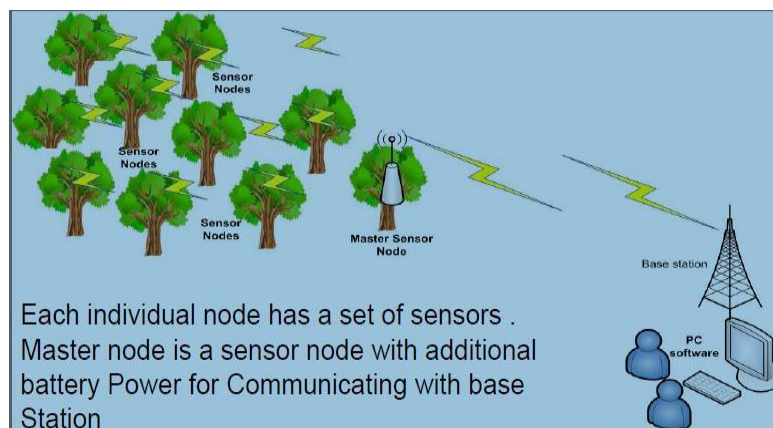

**Fig:** Proposed WSN System Architecture

## 4. IMPLEMENTATION

### 4.1 Block Diagram:

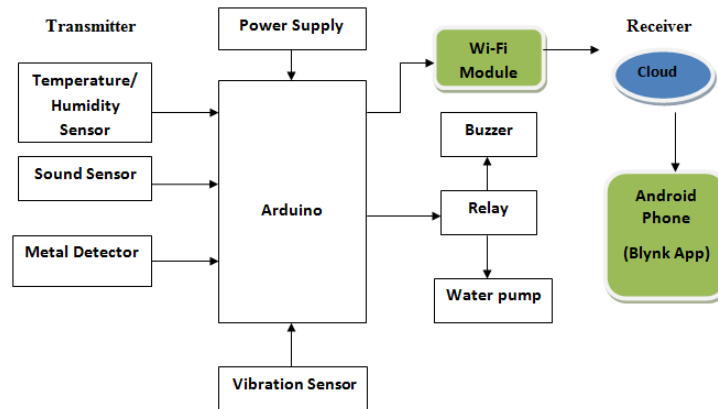

In the System architecture, the transmitter section is a network of portable wireless sensor node which will be equipped at the trunk of the trees in the forest to monitor an illegal cutting of trees in the forest or to inform about occurrence of natural disasters. The another one is receiver section which consist an android smart phone with blynk app installed to communicate with the transmitter section and also it has other devices to alert the user about illegal logging of trees in the forest such as buzzer, water pump .

**At Transmitter side,** The *Power supply* unit supplies power to all the wireless sensor nodes, to the arduino board and to Wi-Fi module. A battery adaptor is used to supply the voltage. It may vary between 3.3V to 12V. *Arduino Uno* is a microcontroller board is a brain of our project. It is a high performance ATmega328 microcontroller and developer by Arduino.cc. It consist 14 digital input/output pins, 6 analog inputs, a 16 MHz ceramic resonator, a USB connection, a power jack. *The Temperature/Humidity sensor* is used to detect the fire or burning of a tree. The sensor is portable which continuously monitor the temperature of the environment, if it detects the temperature value crosses the threshold value limit, controller will alert the user by sending alert message “fire detected” via wi-fi module. The alerting message is travelled to the space blynk cloud and from there to the blynk app. We can watch sensor data over blynk application which receives data continuously from the blynk cloud. It also sends the current humidity value of environment to the app. *The Vibration sensor* is used to identify the unauthorized cutting of tree in forest. It is usually attached to the stem of the tree, when tree is tilting or fall detected i.e. when tilting angle is more than threshold value , it sends an alert message “fall detected” to the user using wi-fi module.

*The Sound Sensor* is a transducer is used to detect the high frequency sound i.e. above the threshold value. It is made up of microphone and some processing circuit which detects sound due to fallen of tree or high frequency human voice or a huge noise generated while cutting the tree which are used by the smugglers. An alert message “high” is sent to blynk app when sound level crosses the threshold value. *The Metal detector* is used here to detect the metal objects which are nearer to the tree. The smugglers may use metal equipments such as axe, saw etc. for cutting tree, when metals make in contact with the sensor part then it detects the metal objects and immediately turn on the buzzer and an alert message “metal detected” is sent to the blynk app.

**At Receiver side,** sensor data is continuously uploaded to cloud (Blynk server) over a Wi-Fi module. Smart phone with blynk app installed will receive the data from the cloud. In case of tilt/vibration sensor, when tree bends or fall detected and with humidity/temp sensor detects fire then water pump is turned on through relay switch, sends fire existence alert message to the blynk app. Metal detector is used to detect and alert the forester/admin when metal object touches to the tree surface.

### 4.2 Sequence diagram of (DHT11 sensor) temperature/humidity working:

The interfacing of temperature/humidity sensor sequence diagram is as shown below. Whenever atmosphere moisture or humidity changes then the conductivity of the substrate varies or electrodes resistance changes. This change is detected by IC which makes ready to read by arduino, later sent to the blynk app via Wi-Fi. Similarly the thermistor is variable resistor whose resistance varies with change in temperature. When fire is detected by this sensor i.e. temperature more than set point, arduino automatically turn ON the water pump and inform the fire detection to the blynk app handler or forester.

The output conditions of the sensor are shown below. Initially the data is in analog form, convert the data into degrees with the help of ADC unit at arduino controller later it send the temperature and humidity values to the blynk app.

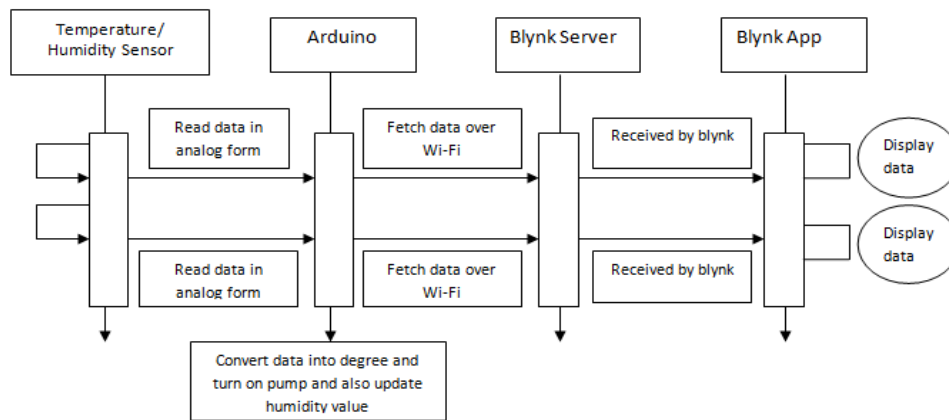

Fig: Sequence diagram of (DHT11 sensor) temperature/humidity working

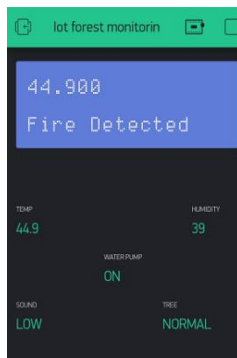

Fig: Temp sensor O/P when Fire detected

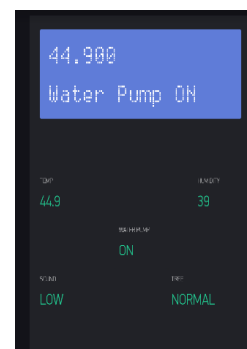

Fig: Water pump is ON after fire detection

### 4.3 Sequence diagram of sound sensor working:

The interfacing sequence diagram of sound sensor is as shown above. This indicates that whenever a sound exceeds a certain threshold value, it is detected by a microphone transducer and fed to the amplifier. Sound threshold can be adjusted by a on board potentiometer. When the sound value increases above threshold level, arduino sends output as HIGH state to blynk app through wi-fi module. It may be generated when tree fall detected or due to higher human voice or equipment sound while cutting trees. LED indication also can be implemented. The two conditions are normal and high sound level detection prompted over blynk app as shown below.

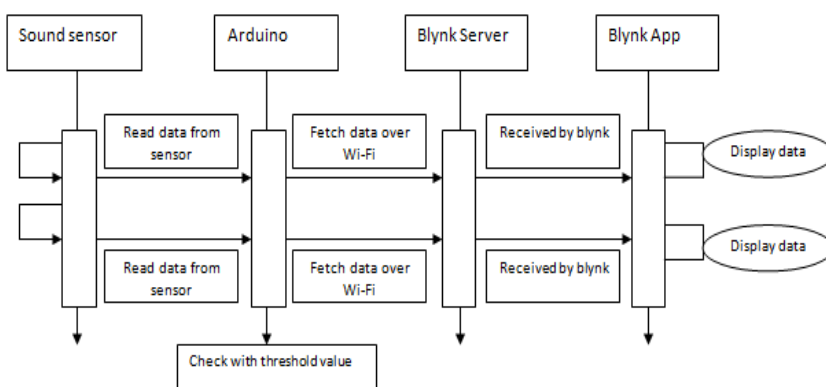

Fig: Sequence diagram of sound sensor working

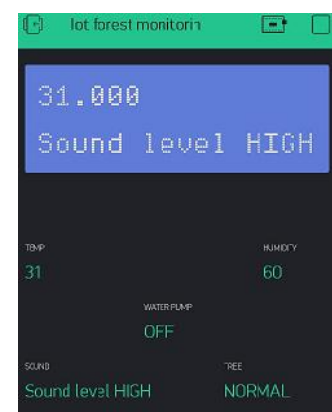

Fig: When Sound Is HIGH

#### 4.4 Sequence diagram of vibration/tilt sensor working:

The interfacing sequence diagram vibration or tilt sensor is as shown below. Vibration sensor has two parts namely a small piece of spring and a metal case. When sensor senses vibration or tilt the spring slightly moves depends on the force applied which measure the tilt or change in angle of the object to which it is attached i.e. if initial position of the sensor is at 90 degree which indicates no tilt is observed and if the position of the sensor is at 180 degree indicates fall detection. The data accessed in both analog and digital form. The output updated to the blynk app with the help of arduino and Wi-Fi module.

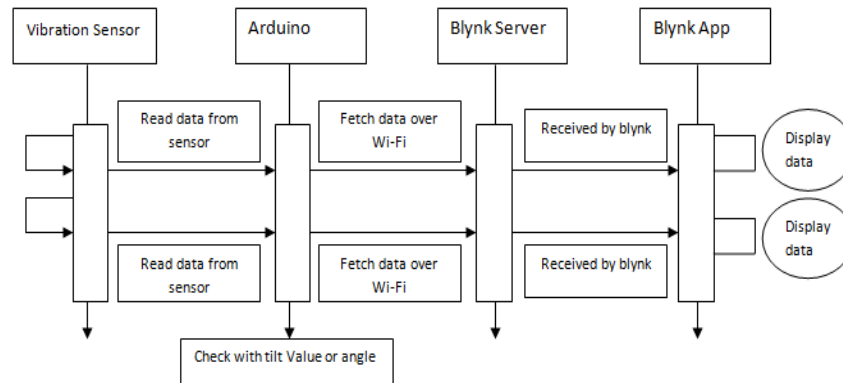

Fig: Sequence diagram of vibration sensor working

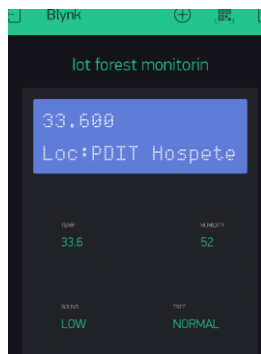

Fig: Sensor O/P when tree is Normal

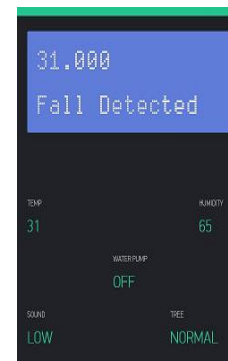

Fig: Sensor output when tree fall detected

#### 4.5 Sequence diagram of Contact base metal detector working:

The below diagram shows sequence of metal equipment tracking and same information sent to the user blynk app. Here we used a contact based metal detector which has MOSFET device. It generates an output value when metal objects touches the part of the sensor i.e. it identifies the metal objects on direct contact or one-to-one contact with it. If smugglers uses metal equipments like axe, saw etc. to cut the tree, while cutting the equipments will have chance of one-to-one contact with metal detector then it alert the blynk app user/forester by sending a message “metal detected” via Wi-Fi module.

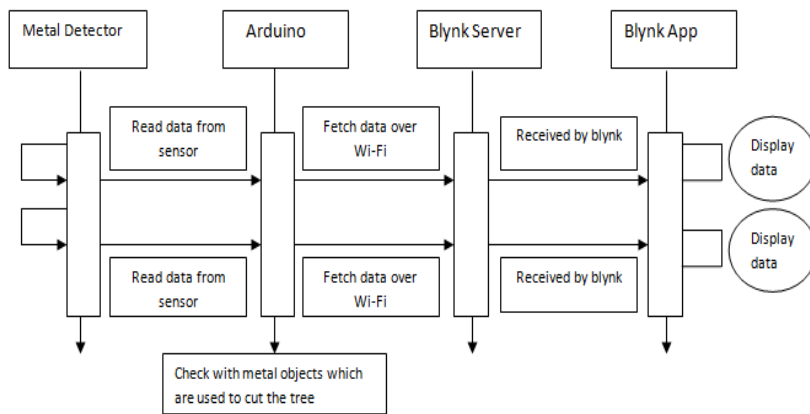
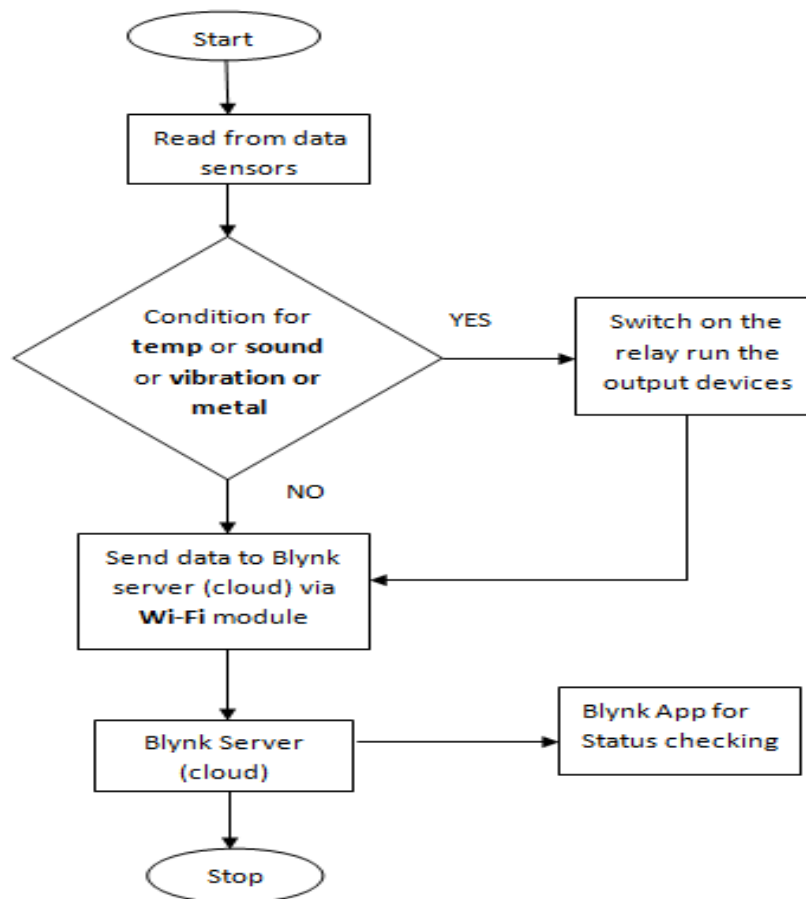

Fig: Sequence diagram of Metal detector working

Fig: When metal objects are detected

### 5. FLOW CHART:



### 6. ADVANTAGES AND DISADVANTAGES:

#### ADVANTAGES:

1. Deforestation can be prevented.
2. Forest trees like sandalwood, teak etc. is protected.
3. This system ensures the protecting wildlife, nature and earth.
4. It can be used for the private plantation area
5. It prevents floods and drought by regulating regional rainfall.

**DISADVANTAGES:**

1. Whether conditions may affect the results.
2. Natural hazards may damage the system.

**7. SCOPE FOR FUTURE WORK**

This project embedded with arduino controller, IOT based WSN node which includes vibration sensor, sound sensor, temperature/humidity sensor, metal detector to detect theft/poaching of trees in forest. Protection of most valuable trees in the forest is the ultimate aim of this system design. We have gone through various experimental approaches to come out with good design.

The scope for future work is designing this system with network of more number of WSN node and inserting of human detective sensors, voice detective micro device, movement detecting transducer, exact location tracking by GPS system, video surveillance for more efficient to gather data such as presence of animals or human being gesture, nearby fire existence and other natural disaster events.

- By installing more sensor nodes more area can be converted for prevention.
- Device structure can be reduced effectively.

**8. CONCLUSION**

This project suggests protecting the valuable forest trees from the smuggling or poaching using microcontroller, IOT and different types of sensor. With above project implementation we conclude that by monitoring the valuable trees of the forest continuously through IOT based wireless sensor network node and with an android app, poaching of valuable trees in the forest can be prevented and necessary action can be taken at real time.

The goal is to decrease smuggling of forest valuable trees and related illegal tree logging cases, which also indirectly enhance the efficiency of forest management system. Thus, from the design of above IOT based WSN node system, poaching of trees or deforestation can be reduced and a balanced ecosystem is achieved.

**REFERENCES**

- [1] www.blynk.cc
- [2] www.arduino.cc
- [3] <https://www.quora.com/How-much-does-1kg-of-sandalwood-cost-in-India>.
- [4] Anil Kulkarni, Ajay Khandare, Mandar Malve, "Wireless Sensor Network (WSN) for protection high cost trees in remote jungles from fire and poaching" „International Seminar on Sandalwood: Current Trends and Future Prospects , Feb 2014,pp.68-73.
- [5] Digital Output MEMS Accelerometer-ADXL345, Analog Devices, 2009, datasheet available at www.analog.com.
- [6] Sridevi Veerasingham, Saurabh Karodi, Sapna Shukla, "Design of Wireless Sensor Network node on Zigbee for Temperature Monitoring",2009 International Conference on Advances in Computing, Control and Telecommunication Technologies, IEEE Journals 978-0- 7695-3915-7/09,2009.
- [7] Manish Y. Upadhye, P. B. Borole, Ashok K. Sharma, "Real-Time Wireless Vibration Monitoring System Using LabVIEW", 2015 International Conference on Industrial Instrumentation and Control Pune, India. May 28-30, 2015, pp. 925-928.
- [8] Jennifer Yick, Biswanath Mukherjee, Dipak Ghosal, Wireless Sensor Network Survey [J].
- [9] M. Tubaishat, S. Madria, Sensor Network an Overview [J]. IEEE Potentials, May 07, 2003
- [10] Lu De Yang Bachelor of Science in Electrical Engineering implementation of a wireless sensor network with ez430-rf2500 development tools and msp430fg4618/f2013 experimenter boards from texas instruments, Jilin University, China, 2009 August 2011.