

Design and Analysis of Compression Spring Mandrell of BENNETT Machine

Mr. Jagdish Pandit Nimbhore, Mr. Tushar D. Garse

¹Pursuing M. Tech, Dept. of Mechanical Engineering, J.T. Mahajan College of Engineering, Faizpur, Jalgaon, Maharashtra, India

²Assistant Professor, Dept. of Mechanical Engineering, J.T. Mahajan College of Engineering, Faizpur, Jalgaon Maharashtra, India

Abstract - The automobile spring is used to observe the vibrations from shock loads due to irregularities of the road surface. It is perform its function without impairing the stability, steering (or) general handling of the vehicle. Generally for light vehicles, coil springs are used as suspension system. A spring is an elastic object used to store mechanical energy and it can be twist, pulled (or) stretched by some force and can return to their original shape when the force is released. The present work attempts to analyze the safe load of the light vehicle suspension spring with different materials. This design includes comparison of modeling and analyses of Big spring made of low carbon-structural steel and chrome vanadium steel and suggested the suitability for optimum design. The results show the reduction in overall stress and deflection of spring for chosen materials. Also the design and process of this spring is very effective with low cost and time saving.

Keywords: Coil Big Springs, Modeling, Static Analysis of Mandrill

1. INTRODUCTION

This section will give you some basic information about springs, what they look like, what their parts are, and how they work. If you already know about springs and want to get right to it.

In order to conserve natural resources and economize energy, weight reduction has been the main focus of automobile manufacturers in the present scenario. Weight reduction can be achieved primarily by the introduction of better material, design optimization and better manufacturing processes. The Compression Big spring is one of the potential items for design optimization. There are three basic types of springs:

Compression springs: Can be found in ballpoint pens, pogo sticks, and the valve assemblies of gasoline engines. When you put a load on the spring, making it shorter, it pushes back against the load and tries to get back to its original length.

Extension springs: Are found in garage door assemblies, vise-grip pliers, and carburetors. They are attached at both ends, and when the things they are attached to move apart, the spring tries to bring them together again.

Torsion springs: Can be found on clipboards, underneath swing-down tailgates, and, again, in car engines. The ends of torsion springs are attached to other things, and when those things rotate around the center of the spring, the spring tries to push them back to their original position.



Figure 1.1 Front Cam and Back Cam

1.2 Objective

This project attempts to understand and investigate the coiling process to improve and maintain delivery performance with good quality, With the help of design optimization of manufacturing process increasing overall equipment Effectiveness and reducing In-house rejection..

1.3 Problem Identification

- The Number of Spring coiling problem that can time consumable and Increasing In-house Rejection .
- Design and optimization of Big spring program
- Low Overall equipment effectiveness.
- Time consumable processing

2. LITERATURE REVIEW

Investigation of Compression spring in the early 60's failed to yield the production facility because of inconsistent fatigue performance and absence of strong need for mass reduction. Researches in the area of automobile components have been receiving considerable attention now. Particularly the automobile manufacturers and parts makers have been attempting to reduce the weight of the vehicles in recent years. Emphasis of vehicles weight reduction in 1978 justified taking a new look at composite springs. Studies are made to

demonstrate viability and potential of FRP(Fibre-reinforced plastic) in automotive structural application. The development of a Big spring is first achieved. Based on consideration fatigue testing, A general discussion on analysis and design of constant springs, variable parameter, of Big spring is presented.

The fundamental characteristics of the variable parameter are evaluated for Big spring application. Recent developments have been achieved in the field of materials improvement and quality assured for springs based on microstructure mechanism. All these literature report that the cost of material; Hence an attempt has been made to fabricate the Big spring with the Low cost with the help of design optimization in coiling process as that of existing process of the spring.

Material properties are reported in many literatures. The experimental procedures are described in national and international standards. Recent emphasis on mass reduction and developments in materials synthesis and processing technology has led to proven production. The more active coils, the less load you will have to apply in order to get it to move a certain distance. Based on these general principles, you now know what to do to change the properties of a spring you already have. For instance, if you want to make automotive valve springs a little stronger than stock, you can a) go to a slightly heavier wire and keep the dimensions and coil count the same, b) decrease the diameter of the spring, keeping the wire size and coil count the same, Decrease the number of active coils, keeping the wire size of spring diameter the same. Naturally, you can also go to a stronger material to achieve the same result. Now, what if you're making a spring from scratch, with nothing to go on in the way of a sample? You can engineer your own design, coil a spring, and then test it. If it's what you want, fine. If it's, let's say, a skosh too strong, then you can a go to a lighter wire, b) open up the coil diameter, or c) increase the number of active coils to get a slightly weaker spring.

Mathematics Naturally, spring design software is available -- here's a very short summary of the mathematics of spring design. These equations, by the way, are taken from The New American Machinist's Handbook, published by McGraw-Hill Book Company, Inc. in 1955. I don't pretend to understand them. There's a lot more in the

$$(1) P = F/K = \frac{\pi d^3 S}{8KD}$$

(1) P = maximum allowable load
F = nominal spring load
S = allowable fiber stress
D = mean coil diameter
d = wire size
K = Wahl stress factor (see 2)

$$(2) K = \frac{4c-1}{4c-4} + \frac{0.615}{c}$$

(2) c = D/d

$$(3) f = \frac{8PD^3}{Gd^4}$$

(3) G = modulus of elasticity
f = deflection per coil

For all springs: A spring under load is stressed. If you put too much stress on a spring, its shape will deform and it will not return to its original dimensions. The material from which the spring is made will have an effect on the strength of the spring: it will also have an effect on how much stress the spring will withstand. The section on spring materials will .The Bennett Making springs by hand basically consists of SH1200 2D wire around a rod called an Catcher and mandrel you more about this. When you heat spring wire, it may change its dimensions. Again, the section on materials will tell you more about this.

If the spring will set solid (compress all the way, so that all the coils touch each other) at the limit of its travel, the diameter of the wire times the number of coils cannot be greater than the space allowed, unless you want the spring itself to act as a mechanical stop to the motion.

Springs that operate in a high-temperature environment (like for instance inside an engine) will need to be made slightly longer to compensate for the fact that the heat may have an effect on the length of the spring.

The section on finishing will tell you more about this. As a compression spring assumes a load and shortens, the diameter of the active coils will increase. This is only a problem when the spring has to work in a confined space.

3. EXPERIMENTAL WORK

Design And Analysis of Compression Spring Mandrell of BENNETT Machine, Types of cam used for testing,

Front Cam and Back Cam

This is the second stage that will tell you how to make springs. The information covered on this procedure is necessary, no matter what kind of spring you want to make. Compression springs, and finishing techniques, will round out the subject. To get the most from these pages you should have your wire, your tools, and the design in mind for a spring you want to make. For info on

coiling without a one part Mandrill, see the section on compression springs. NOTE: I'm planning to make an spring showing the coiling process, but it's turning out to be a MAJOR project the mandrill is secured in the chuck of a Bennett machine. This section will tell you how to get the right diameter on mandrill, but it's also important to get the right length. Correct spring length is important because it's difficult (not impossible, but difficult) to coil a spring on

an mandrill (mandrill made up of number of gutty set which is secured in the chuck of Bennett machine and lock to their other end so that big spring can easily coiled).

3.1 Front Cam

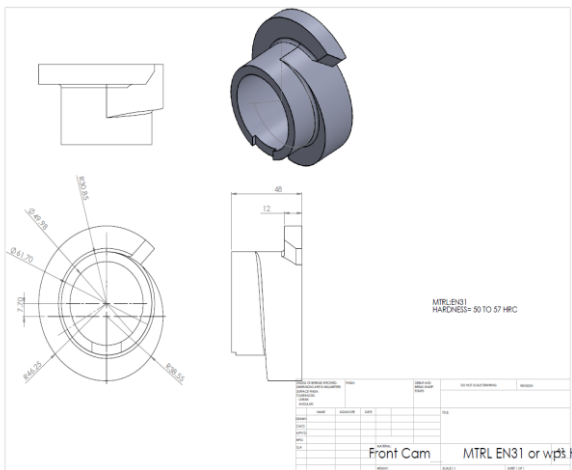

3.2 Back Cam

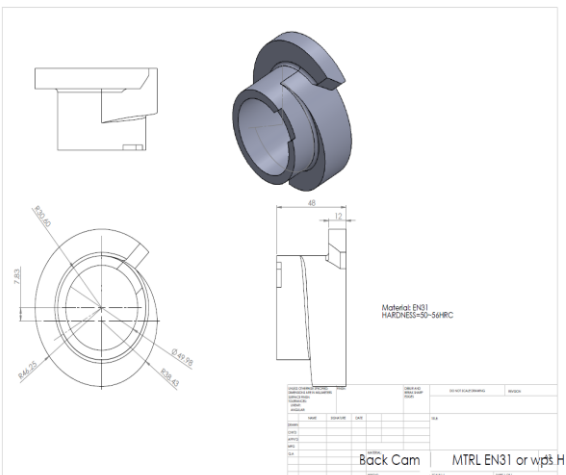

4. CONCLUSIONS

The Results obtained are quite favorable which was expected. The Big spring is designed according to constant cross-section area method. The 2-D model of the Big spring is analyzed. Static test has been conducted to predict the stress and displacement at different locations

for various load value. The results of the FEM analysis are verified with the test results. A comparative study has been made between one piece mandrill and set of gutty mandrill springs with respect to time, riding quality, cost and strength. From the study it is seen that the Big spring manufacture by using gutty mandrill process is more economical than that of Big spring manufacture by using one piece of mandrill performance. Hence, the gutty mandrill springs process are the suitable replacements to the existing process. Similarly existing process require more than 6 operators, Front and back cam mandrel require single operator to achieved desired results.

REFERENCES

- [1] T.D. Gillespie (1992), "Suspensions in fundamentals of vehicle dynamics", society of automotive engineers, USA, pp.97-117 & pp.237-247.
- [2] Kaiser B., Pyttel B. and Berger, C., "VHCF behaviour of helical compression springs made of different materials", International Journal of Fatigue, vol. 33, 2011, pp. 23-32.
- [3] Roy DK, Saha KN. Nonlinear Analysis of Leaf Springs of Functionally Graded Materials. Chemical, Civil and Mechanical Engineering Tracks of 3rd Nirma University International Conference (NUICONE 2012). Procedia Eng. 2013; 51: 538- 43p.
- [4] Kuehjoo, Faristarlochan, " Finite element analysis on the static and fatigue characteristics of composite multi-leaf spring", Journal of Zhejiang University-SCIENCE A Applied Physics & Engineering, ISSN 1673-565X, Vol13,2012,pp.159-164.
- [5] KMT LTD. Jalgaon one of the excellent quality springs manufacturer in India, with ISO 9001-2008, IATF system.
- [6] N.K. Mukhopadhyay, B. Ravi kumar, D.K. Bhattacharya "Failure analysis of passenger car coil spring"(2006)
- [7] P.S.Valsange Design of Helical Coil Compression Spring, IJERA, Vol. 2, 6, November-December 2012.
- [8] S.S.Gaikwad, P.S.Kachare, Static Analysis of Helical Compression Spring Used in TwoWheeler Horn, IJEAT, Volume-2, February 2013M. Young, The Technical Writer's Handbook. Mill Valley, CA: University Science, 1989.
- [9] Jadhav, "Analysis of Helical Spring in Monosuspension System Used in Motorcycle" International Journal of Research in Advent Technology, Vol 2, No. 10, October 2014 E-ISSN: 2321-9637