

CHAINLESS BICYCLE WITH BALL BEARING DRIVE SHAFT

Suraj Pawar¹, Sominath Ahewad², Swapnil Randive³, Ramjan Reghiwale⁴, Sagar Mushan⁵

¹⁻⁴Students, Department of Mechanical Engineering, MIT-Academy of Engineering, Pune, Maharashtra, India

⁵Faculty, Department of Mechanical Engineering, MIT-Academy of Engineering, Pune, Maharashtra, India

Abstract: - A chainless bicycle is a bicycle in which the power from pedal to rear wheel of the bicycle is transmitted by means using bevel gear and ball bearing arrangement instead of a using the conventional chain drive. The main of the project is to obtained a maximum displacement of bicycle by transmitting the maximum possible torque from pedal to rear wheel, for a minimum applied force, reducing the human effort and obtain different speed.

applied force, reducing the human effort and obtain different speed.

2 SELECTION OF METHODOLOGY

2.1 Selection of Bevel Gear

Chainless bicycle has a bevel gear, connecting rod and bearing system where a conventional bicycle would have its chain ring. In this mechanism one end of driven shaft has a bevel gear arrangement and other end of shaft a ball bearing arrangement. In bearing arrangement there is a ring of bearing work in harmony to deliver a Greater power, playing a pivoted role in performance of speed.

Bevel gears are gears where the axes of the two shafts intersect and the tooth- Bearing faces of the gears themselves are conically shaped. Bevel gears are most often mounted on shafts that are 90 degrees apart, but can be designed to work at other angles as well. The pitch surface of bevel gears is a cone. The pitch surface of a gear is the imaginary toothless surface that you would have by averaging out the peaks and valleys of the individual teeth. The pitch surface of an ordinary gear is the shape of a cylinder. The pitch angle of a gear is the angle between the face of the pitch surface and the axis. The most familiar kinds of bevel gears have pitch angles of less than 90 degrees and therefore are cone-shaped. This type of bevel gear is called external because the gear teeth point outward. The pitch surfaces of meshed external bevel gears are coaxial with the gear shafts; the apexes of the two surfaces are at the point of intersection of the shaft axes.

Keywords: chain and sprocket, bevel gear, shaft, reliability.

1 INTRODUCTION

The shaft drive has been developed more recently and only few companies are manufacturing those types. The shaft drive uses a shaft instead of a chain to transmit power from the rider's legs to the wheels. Typically, gears are sealed inside a housing that are attached to the main shaft. The number of the shaft drive manufacturers is increasing and public interests are growing as well. It is slowly changing the bike industry. The engineer is constantly conformed with the challenges of bringing ideas and design into reality.

New machines and techniques are being developed continuously to manufacture various products at cheaper rates and high quality. So, we are going to make a machine for cycle industry using bevel gear gives mechanical advantages and make it multipurpose.

In conventional machining there was a problem associated with chain dropping due to misalignment of rear wheel sprocket and wheel. To avoid such consequences, we are making chainless bicycle. In chainless bicycle we are running the rear wheel by using driven shaft and ring bearing. bearing play a pivoted role in power transmission. the main of the project is to obtained a maximum displacement of bicycle by transmitting the maximum possible torque from pedal to rear wheel, for a minimum



Fig 1 Spline Bevel Gear

2.2 DRIVE SHAFT

A shaft is a rotating machine element which is used to transmit power from one place to another. The power is delivered to the shaft by some tangential force and the resultant torque (or twisting moment) set up within the shaft permits the power to be transferred to various machines linked up to the shaft.

In a chainless cycle, a drive shaft takes over the role of the chain. The pedals are connected to the drive shaft by gears, allowing the drive shaft to transfer power from the pedals to the rear wheel. The power from the drive shaft then spins a shaft rod that propels the rear wheel, providing the cycle with power. The drive shaft connects to a hub transmission that replaces the stacked gears found on a conventional bicycle. This transmission is factory-lubricated and sealed permanently.

2.3 BEARING

A bearing is a machine element that constrains relative motion and reduces friction between moving parts to only the desired motion. The design of the bearing may, for example, provide for free linear movement of the moving part or for free rotation around a fixed axis; or, it may prevent a motion by controlling the vectors of normal forces that bear on the moving parts. Bearings are required for the front and rear axles.



Fig 2 Bearing

3. MATERIAL

Table -1. Material Selection

Sr. No.	Part Name	Material
1	Shaft	En-8
2	Pedestal Bearing	Cast Iron
3	Bevel Gear Set	Alloy Steel
4	Cycle	Std
5	Small Bevel Gear	Alloy Steel
6	Ratchet	Std
7	Frame	Ms
8	Ms Plate	Mild Steel
9	Universal Joint	Alloy Steel
10	Rod	Mild Steel

4. DESIGN CALCULATION

4.1 DESIGN OF THE DRIVER PEDAL

Material selection: -

Table 2 design of the driver pedal

Designation	Ultimate Tensile Strength N/Mm ²	Yield Strength N/Mm ²
EN 9	650	480

Cross section of link may be determined by considering lever in bending;

The linkage has an section of (25 x 10) mm

Let; t= thickness of link

B= width of link

Bending moment;

Section modulus; $Z = \frac{1}{6} tB^2$

$$F_b = \frac{m}{z} = \frac{PL}{\frac{1}{6}tB^2} = \frac{6PL}{tB^2}$$

Maximum effort applied by hand (P) = 200 N

$$\Rightarrow fb = \frac{6 \times 200 \times 120}{10 \times 25^2}$$

$$fb = 23.02 \text{ N/mm}^2$$

As $fb_{act} < fb_{all}$

Thus, selecting an (25 x 10) cross-section for the link.

4.2 DESIGN OF PEDAL SHAFT.

Material selection: -

Table 3 design of Pedal Shaft

Designation	Ultimate Tensile Strength N/Mm ²	Yield Strength N/Mm ²
EN 24	800	680

Since the loads on most shafts in connected machinery are not constant, it is necessary to make proper allowance for the harmful effects of load fluctuations

According to ASME code permissible values of shear stress may be calculated from various relations.

$$= 0.18 \times 800$$

$$= 144 \text{ N/mm}^2$$

OR

$$f_{s \text{ max}} = 0.3 f_{yt}$$

$$= 0.3 \times 680$$

$$= 204 \text{ N/mm}$$

Considering minimum of the above values;

$$\boxed{f_{s \text{ max}} = 144 \text{ N/mm}^2}$$

Shaft is provided with key way; this will reduce its strength. Hence reducing above value of allowable stress by 25%

$$\boxed{f_{s \text{ max}} = 108 \text{ N/mm}^2}$$

This is the allowable value of shear stress that can be induced in the shaft material for safe operation.

4.3 TO CALCULATE PEDAL SHAFT TORQUE

Note that torque at the pedal shaft is $200 \times 120 = 2400 \text{ N-mm}$

$$\Rightarrow T_{\text{design}} = 2.4 \text{ N-m}$$

check for torsional shear failure of shaft.

Assuming minimum section diameter on input shaft = 14mm, note that this dimension is the smallest section of the main shaft where the lobe plate is mounted, hence, (manufacturing consideration).

$$\Rightarrow d = 14 \text{ mm}$$

$$T_d = \pi / 16 \times f_{s \text{ act}} \times d^3$$

$$\Rightarrow f_{s \text{ act}} = \frac{16 \times T_d}{\pi \times d^3}$$

$$= \frac{16 \times 2.4 \times 10^3}{\pi \times 14^3}$$

$$\boxed{f_{s \text{ act}} = 4.45 \text{ N/mm}^2}$$

As $f_{s \text{ act}} < f_{s \text{ all}} \Rightarrow$ I/P shaft is safe under torsional load.

4.4 DESIGN OF OTHER PARTS AND THEIR DESIGN CONSIDERATIONS:

1. Selection of timer pulley, timer belt and output pulley arrangement from pedal to flywheel shaft
2. Selection of chain sprocket, chain and free wheel arrangement from flywheel to wheel.

3. System design for Gravity flywheel, as to calculation of desired output for optimized performance
4. Design of flywheel hub
5. Unidirectional clutch design
6. Un-balance mass selection
7. Gear train design
8. Shock-absorber design
9. Hinge bracket for seating design
10. Rack and pinion design for – e-shock
11. Output –augmentation using e-shock theoretical derivation
12. Theoretical derivation of energy augmentation using the combined system.

The design of all the above components will be done with consideration of the system of forces acting on each component by drawing free body diagrams, determination of forces on components, determination of theory of failure and cross check of the derived dimensions for safety for given material of part under consideration.

4.5 DESIGN OF UNIDIRECTIONAL CLUTCH/FREEWHEEL

Clutch terminology

Mt	Transmitted Torque Kgf.cm
Z	Number of rollers
R	Inner radius of outer ring
Ft	Tangential force, Kgf
Fn	Normal force, Kgf
α	Angle between runner surface & tangent to roller
β	Friction angle ($\alpha / 2$)
D	Diameter of roller
Po	Pressure on the projected area of roller (Kgf/mm ²)
Mb ₁	Bending movement on ring kgf-cm
Rm	Mean radius of ring cm
T	Thickness of ring
fb	bending stress (kgf-cm)
B	width of ring

Z_1 Modulus of area of ring
(cm^3)

Y Deformation of ring at the point of action of tone F

K_1, K_2 Constant depending on number of rollers

$$\Rightarrow t = 5\text{ mm}, 6\text{ mm}, 8\text{ mm}.$$

Selecting $t = 5\text{ mm}$.

$$\Rightarrow R = \frac{D_o - 5}{2}$$

$$\Rightarrow R = 30\text{ mm}$$

Now;

$$\Rightarrow a = \frac{(R-d)}{2} \cos\alpha - \frac{d}{2}$$

$$a = 18.77$$

$$18.77 = \frac{(30-9)}{2} \cos\alpha - \frac{9}{2}$$

$$\Rightarrow \alpha = 28.89^\circ$$

Now;

Torque transmitting capacity of clutch

$$M_t = F_t \times Z \times R$$

Where $F_t = F \sin \beta$

$$\text{But } \beta = \alpha = \frac{14.445^\circ}{2}$$

$$F_t = 0.425\text{ kgt}$$

$$M_t = 0.425 \times 5 \times 3.0$$

$$\Rightarrow M_t = 6.37966\text{ Kgf/cm}^2$$

\Rightarrow Torque transmitted capacity of clutch is 6.37966 Kgf/cm^2 & as it is larger than the actual torque 5.968 Kgf/cm^2

\Rightarrow clutch is safe.

Check for bending failure

$$M_{b1} = C_1 \times F \times R_m$$

$$\text{Where } R_m = \frac{1}{2} (D + t)$$

$$= \frac{1}{2} (56 + 5)$$

$$R = 30.5\text{ mm}$$

$$R = 3.05\text{ cm}$$

$$C_1 = 0.1076$$

Now,

$$M_{b1} = 0.1076 \times 3.05 \times 1.705$$

$$M_{b1} = 0.5595\text{ Kgf/cm}^2$$

$$\text{Now } f_{b_{act}} = M_b = \frac{M_b}{Z_1}$$

Design of Roller

Design calculations

We know that;

$$A = \frac{(R-d)}{2} \cos \frac{d}{2}$$

$$\text{Where; } R = \frac{D_o}{2t}$$

Now; t = thickness of ring

$$T = \frac{C_2}{2} + \sqrt{C_2 D}$$

$$\& C_2 = \frac{3C_2 F}{b}$$

$$= C_3 F / b$$

Recommended dimensions for unidirectional clutches

Width of roller clutch = Length of roller = 14
= **1.4 cm**

Now;

Torque = Force x radius

$$5.968 = \frac{F D_o}{2}$$

$$\Rightarrow F = 1.705\text{ Kgf}$$

Now;

$$\Rightarrow C_2 = C_3 \times \frac{F}{b}$$

$$C_2 = \frac{1.61 \times 1.705 \times 10^{-4}}{1.4} \text{ (for 5 rollers)}$$

$$\Rightarrow C_2 = 1.96 \times 10^{-4}$$

$$\Rightarrow t = C_2 + \frac{\sqrt{C_2 D}}{2}$$

$$= 1.96 \times 10^{-4} + \sqrt{1.96 \times 10^{-4} \times 56}$$

$$= 0.1048\text{ cm}$$

$$\Rightarrow t = 1.048\text{ mm}.$$

But the standard thickness available for the roller clutch ring is

$$= \frac{Mb}{bt^3} = \frac{0.5595 \times 12}{14 \times 5^3}$$

$$fb_{act} = 0.0038 \text{ Kgf/cm}^2$$

As value of (actually induced Stress) is far below the permissible value the clutch is safe in bending.

4.6 SELECTION OF BEARING

Spindle bearing will be subjected to purely medium radial loads; hence we shall use ball bearings for our application.

Selecting; Single Row deep groove ball bearing as follows.

Ref. "PSG. Design Data Book"

Table 4 Bearing (Series 62)

ISI No	Bearing of basic design, No (SKF)	D	D1	D	D ₂	B	Basic capacity (N)	
17AC03	6003	17	19	35	33	10	2850	4650

$$P = X F_r + Y F_a$$

Neglecting self-weight of carrier and gear assembly

For our application $F_a = 0$

$$\Rightarrow P = X F_r$$

where $F_r = R_a$

As; $F_r < e \Rightarrow X = 1$

$$\Rightarrow P = 198.54 \text{ N}$$

Calculation dynamic load capacity of bearing

$$L = \frac{(C)^p}{P}, \text{ where } p = 3 \text{ for ball bearings}$$

For m/c used for eight hrs. of service per day;

$$L_H = 12000 - 20000 \text{ hrs.}$$

$$\text{But; } L = \frac{60 n L_h}{10^6}$$

$$L = 600 \text{ million rev.}$$

$$\text{Now; } 600 = \frac{(C)^3}{(198.54)^3}$$

$$\Rightarrow C = 1674.55 \text{ N}$$

\Rightarrow As the required dynamic capacity of bearing is less than the rated dynamic capacity of bearing;

\Rightarrow Bearing is safe

SELECTION OF BEARING 6002ZZ

Shaft bearing will be subjected to purely medium radial loads; hence we shall use ball bearings for our application.

Selecting; Single Row deep groove ball bearing as follows.

Ref. "PSG. Design Data Book"

Table 5 Bearing (Series 60)

ISI No	Bearing of basic design, No (SKF)	d	D1	D	D ₂	B	Basic capacity (N)	
15AC03	6002	15	17	32	30	9	2550	4400

$$P = X F_r + Y F_a$$

For our application $F_a = 0$

$$\Rightarrow P = X F_r$$

As; $F_r < e \Rightarrow X = 1$

$$\Rightarrow P = F_r$$

Max radial load = $F_r = 180 \text{ N.}$

$$\Rightarrow P = 180 \text{ N}$$

Calculation dynamic load capacity of bearing

$$L = \frac{(C)^p}{P}, \text{ where } p = 3 \text{ for ball bearings}$$

For m/c used for eight hrs. of service per day;

$$L_H = 4000-8000 \text{ hrs.}$$

$$\text{But; } L = \frac{60 n L_h}{10^6}$$

Assuming max. speed of device 200 rpm.

$$L = 48 \text{ million rev.}$$

$$\text{Now; } 48 = \frac{(C)^3}{180}$$

$$\Rightarrow C = 17.9 \text{ N}$$

\Rightarrow As the required dynamic capacity of bearing is less than the rated dynamic capacity of bearing.

5. CAD DESIGN

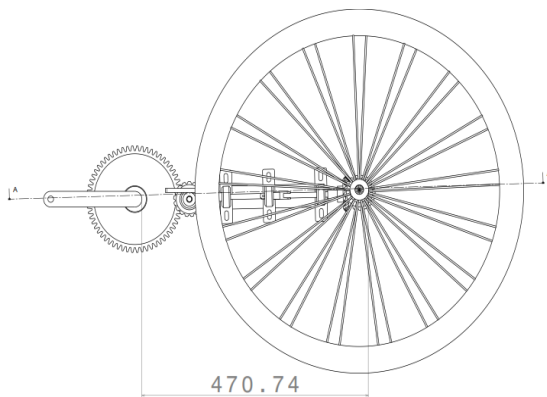

Fig.3 CAD Design

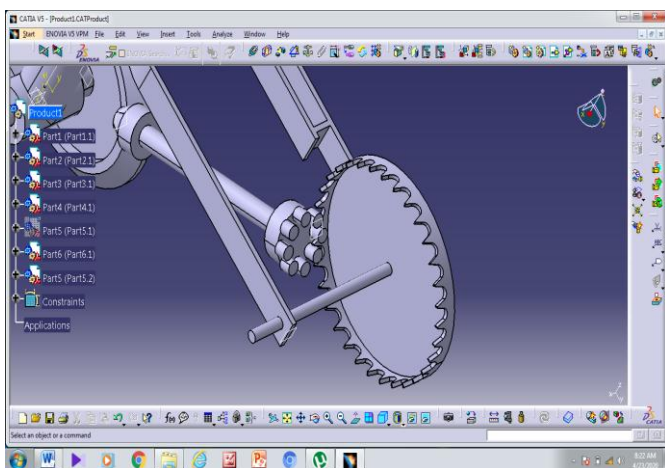

Fig.4 Catia Model

6. CONCLUSION

Instead of chain drive one-piece drive shaft for rear wheel drive bicycle have been optimally designed and manufactured for easily power transmission. The drive shaft with the objective of minimization of weight of shaft which was subjected to the constraints such as torque transmission, torsion buckling capacity, stress, strain, etc. The torque transmission capacity of the bicycle drive shaft has been calculated by neglecting and considering the effect of centrifugal forces and it has been observed that centrifugal force will reduce the torque transmission capacity of the shaft. The solid shaft gives a maximum value of torque transmission but at same time due to increase in weight of shaft. The results obtained from this work is a useful approximation to help in the earlier stages of the development, saving development time and helping in the decision-making process to optimize a design. The

drive shaft has served as an alternative to a chain-drive in bicycles for the past century, never becoming very popular.

REFERENCES

Journal Papers:

- [1]. Dandage R.V, Patil A.A. Kamble P.N.2017 "DESIGN, ANALYSIS & FABRICATI.N OF SHAFT DRIVEN BICYCLE", International Journal of Emerging Engineering Research and Technology, P.P.14-15
- [2]. Design & Fabrication of Shaft Driven Bicycle Anmol Parashar from IJSTE - International Journal of Science Technology & Engineering | Volume 2 | Issue 11 | May 2016
- [3]. Allwin Glover C, Prabu Ram G, 2015, "Shaft Driven Transmission in Velocipede", IOSR Journal of Mechanical and Civil Engineering (IOSR-JMCE) e-ISSN: 2278-1684, p-ISSN: 2320-334X, Volume 12, Issue 2 Ver. II (Mar - Apr. 2015), PP 45-49.
- [4]. Jyoti A. Durgude, Gawade S.R. "Design of Dual Mode Bicycle by Using Gear Box" International Journal of Engineering and Innovative Technology (IJEIT)", Volume 4, Issue 12, June 2015.

BOOKS

- Machine design by R.S. khurmi and J.K. Gupta
- Machine Design – "Design Data Book" [10].
- Machine Design by V.B. Bhandari