

# MODELLING AND ANALYSIS OF HIGH FREQUENCY POWER INVERTER FOR WIRELESS POWER TRANSFER

Ms. Nandini N<sup>1</sup>, Mrs. Poornima H S<sup>2</sup>

<sup>1</sup>M. Tech CAID, Dept. of Electrical & Electronics Engineering, The National Institute of Engineering, Mysuru, Karnataka, India

<sup>2</sup>Assistant Professor, Dept. of Electrical & Electronics Engineering, The National Institute of Engineering, Mysuru, Karnataka, India

\*\*\*\*\*

**Abstract** - Wireless power transmission [WPT] is the innovation that could free people from wires. Lately, Wireless power transmission innovation has been advancing quickly, and power is the mastermind frame network. This project describes the design of an IC control circuit with high-frequency Power Inverter using STM32F103C6 a pulse width modulation (PWM) and IR2104 gate driver IC. The architecture of the WPT program provides a closed-loop system for bridge fault diagnosis. The proposed concept has the potential to produce a single-phase high-frequency AC voltage of 15V (for experimental purposes) at a frequency of 110 KHz.

**Key Words:** Power Inverter, High Frequency, Pulse Width Modulation, Wireless Power Transmission, Wireless Power Transfer Network Closed Loop

## 1. INTRODUCTION

WPT frameworks would now be able to be fabricated utilizing different techniques after numerous long stretches of advancement Which incorporate lasers, microwaves, and fields of coupling [1].

Original business WPT utilizes consolidated inductance for low-power remote charging (for example cell phone charging), yet this gadget is considered to have frail charging efficiencies and works just over a thin range[2].

Inverters are utilized in many applications where direct current must be changed over to substituting current. Inverters may create alternating current as much as a kilo, mega or gigahertz frequencies.

Pulse width modulated (PWM) inverters are leading electronic force circuits used in reasonable applications. They are also suitable for assembling variable size air conditioning voltages as a factor recurrence. The yield voltage norm is more striking than a square wave inverter. A three-stage form, the PWM inverter is likewise a solitary stage. There are a few other PWM strategies, the SINE-PWM technique, the Space Vector dependent PWM procedure, the current PWM strategy based on controller hysteresis are some of the significant ones [3].

The Single-Phase PWM inverter can be constructed from two half Connecting bridge to create a complete bridge or H-bridge. This Comprises DC source voltage, four Powers switches, and Load.

This paper describes a single-phase high frequency and high-power inverter configuration that is used for wireless power transfer.

## 2. SYSTEM CONFIGURATION

### 2.1 STM32F103C6 Pin Configuration

The STM32F103C6 is a 48 pin Ic and operates at a frequency of 72MHz with additional features such as serial ports SPI, PWM and prototyping as well[4].

For this configuration the switching frequency is 110 KHz. The PWM frequency depends on the capacitor timing, and resistance timing.

The power generated by STM32F103C6 isn't enough to turn the inversion component's MOSFET modules. And they introduced the gate drive module IR2104.

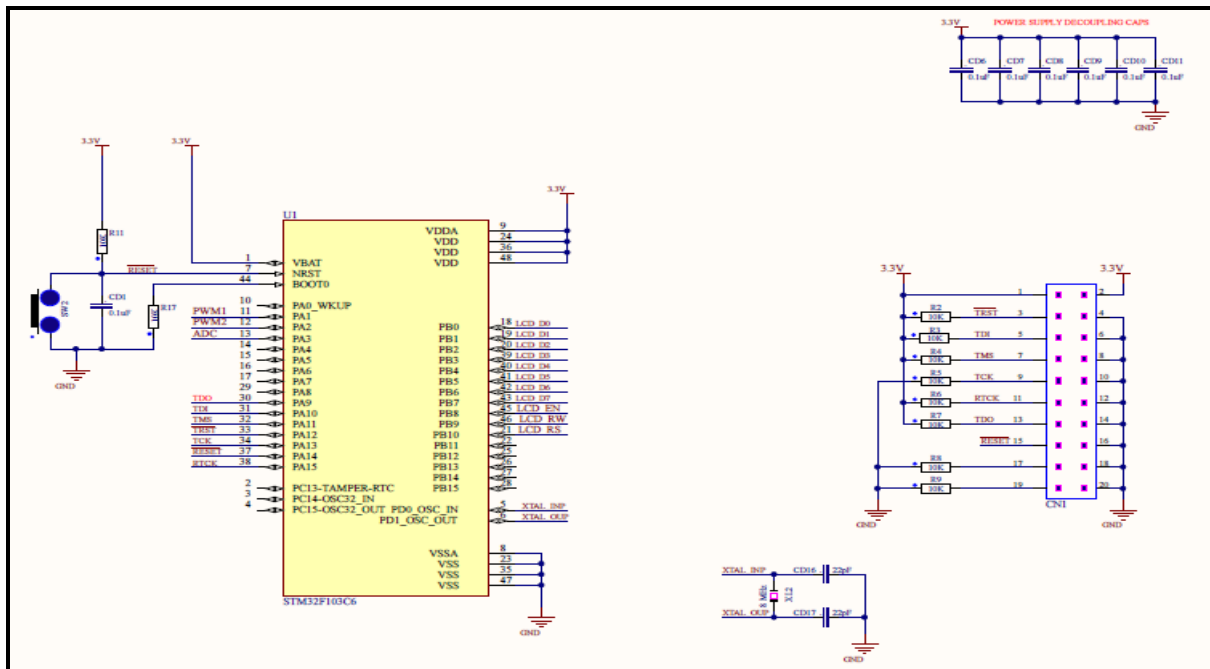

Figure-1: STM32F103C6 Pin Configuration

## 2.2 MOSFET with Gate Driver Configuration

For switching purposes, IRFZ44 Power MOSFET is used. It fit best with low-resistance, fast-switching, rugged system design and cost-effectiveness.

IRFZ44 Power MOSFET has a maximum VDS of 60V, 50A ID and working temperatures between -55 and +175. IR2104 modules can take and amplify the signals coming from the microcontroller outputs [5].

Each IR2104 driver can control one MOSFET model directly. Signals produced by STM32F103C6 will link to IR2104 as follows:

- The "PWM1" channel flips first driver's "High" input and second driver's "Low" data.
- Channel "PWM2" flips first driver's "High" input and second one's "Low" input.

An inductive load is associated at the inverter output for experimental purposes. In real-world, wireless transmitter coil must replace inductive load, which transmits power to the receiver coil that will be rectified and supplied to the charging applications.

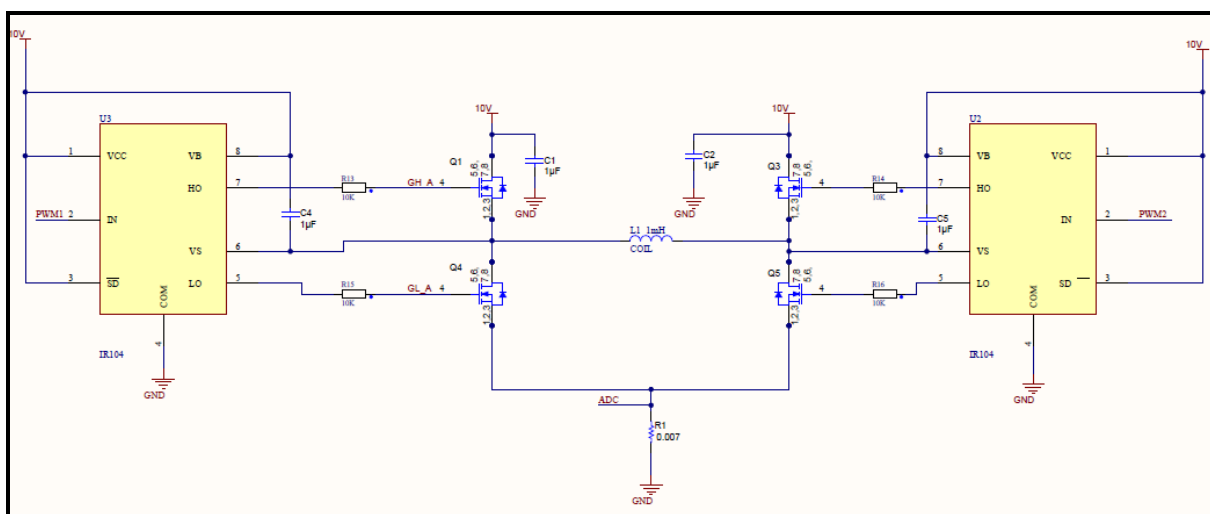

Figure- 2: MOSFET with Gate Driver Configuration

### 2.3 Fault Diagnosis Flow Chart

Figure -3 shows a flow chart for fault diagnosis. If the bridge fault occurs in the network, it immediately prevents the power transmission by displaying the LCD as a failure. Unless the system has no faults, the power transmission begins by displaying it in LCD as transmitting.

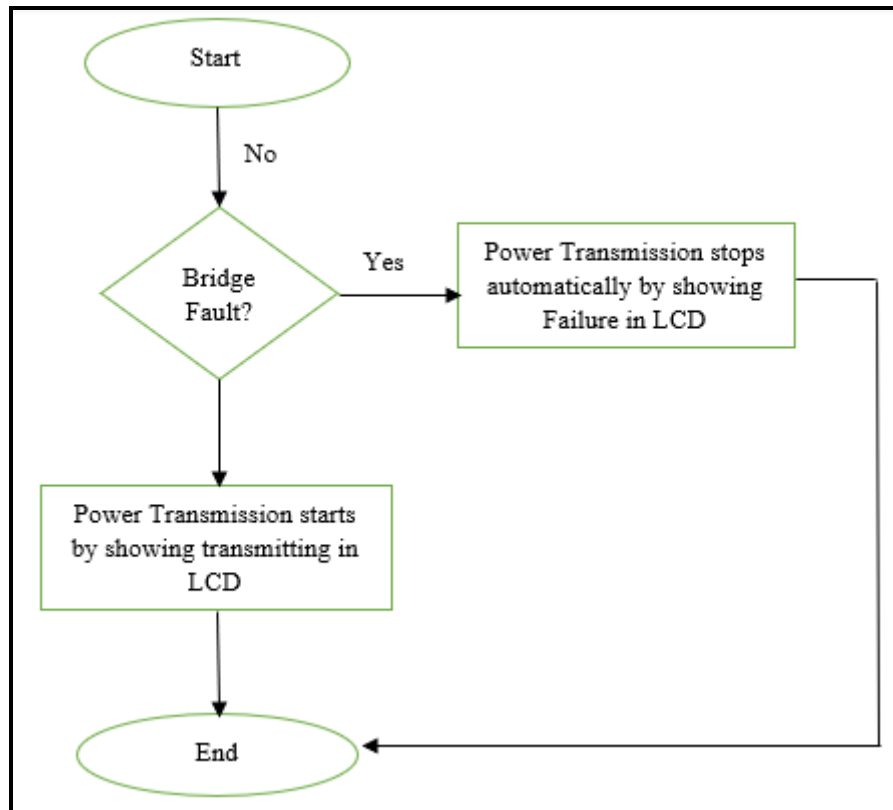

Figure- 3: Flow Chart

### 3. METHODOLOGY

The power transform method is done as follows.

- The power supply is provided to the control IC circuit STM32F103C6 the produced output is not sufficient for the bridge circuit to be worked.
- The IR2104 driver IC recognizes low power from the IC circuit controller and creates high back for the power transistor entryway.
- The dc signal is converted to an ac signal in the inverter-bridge circuit. The H-Bridge MOSFETs are used to invert the dc into ac, and power is transmitted via the (real world) coils.
- When any faults occur during power transmission, the fault detection circuit will detect them. If any faults occur in the circuit, the power transmission to the applications is automatically stopped.

### 4. SIMULATION AND RESULTS

In this section Proteus Simulation of high-frequency inverter topology is carried out.

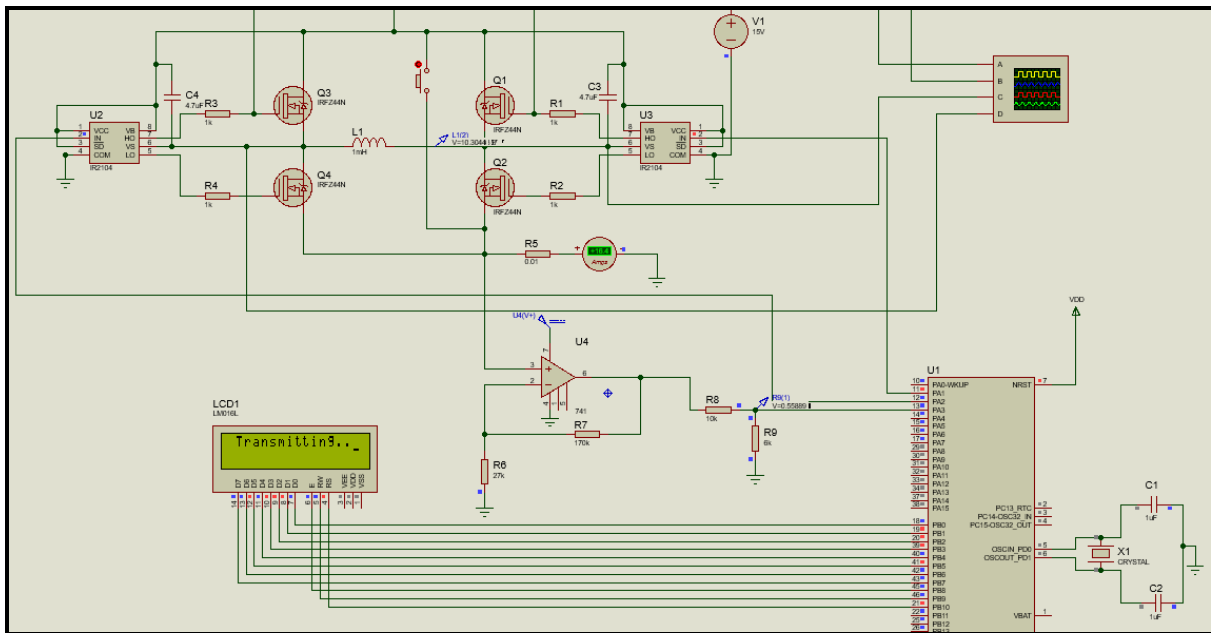

Figure-4: Simulation of Inverter Circuit Without Bridge Fault

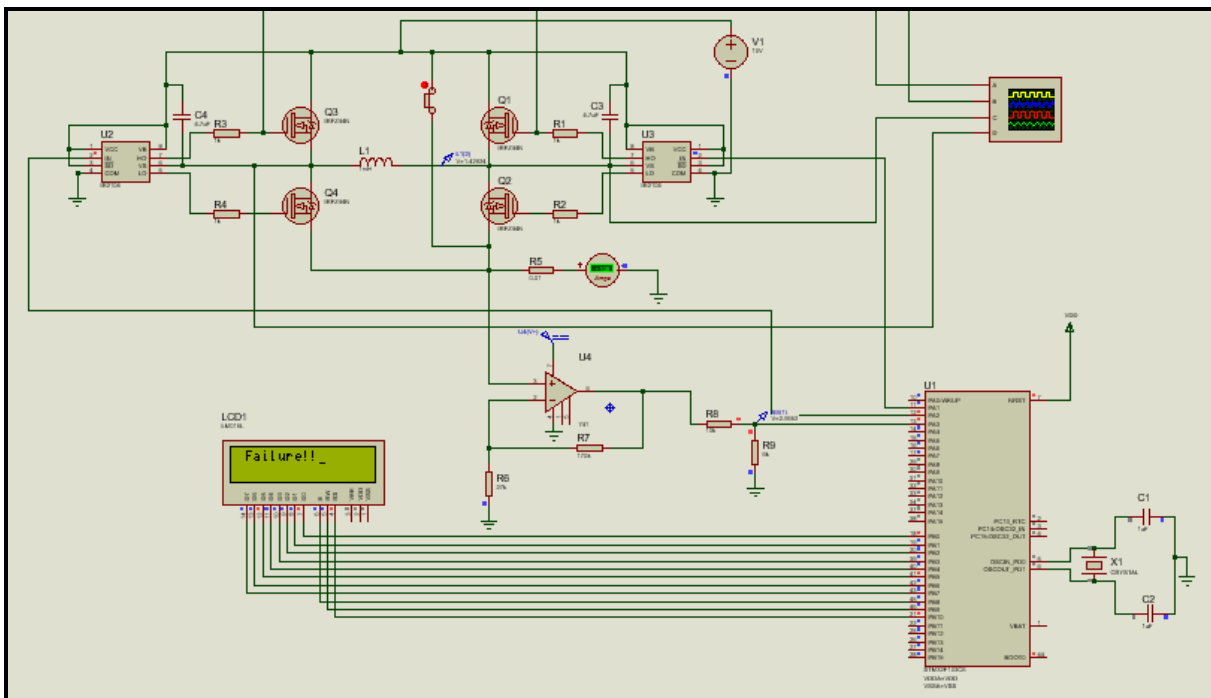

Figure-5: Simulation of Inverter Circuit with Bridge Fault

PWM Technique is used to control the inverter output. The Yield of the H-Extension Inverter appeared as follows.

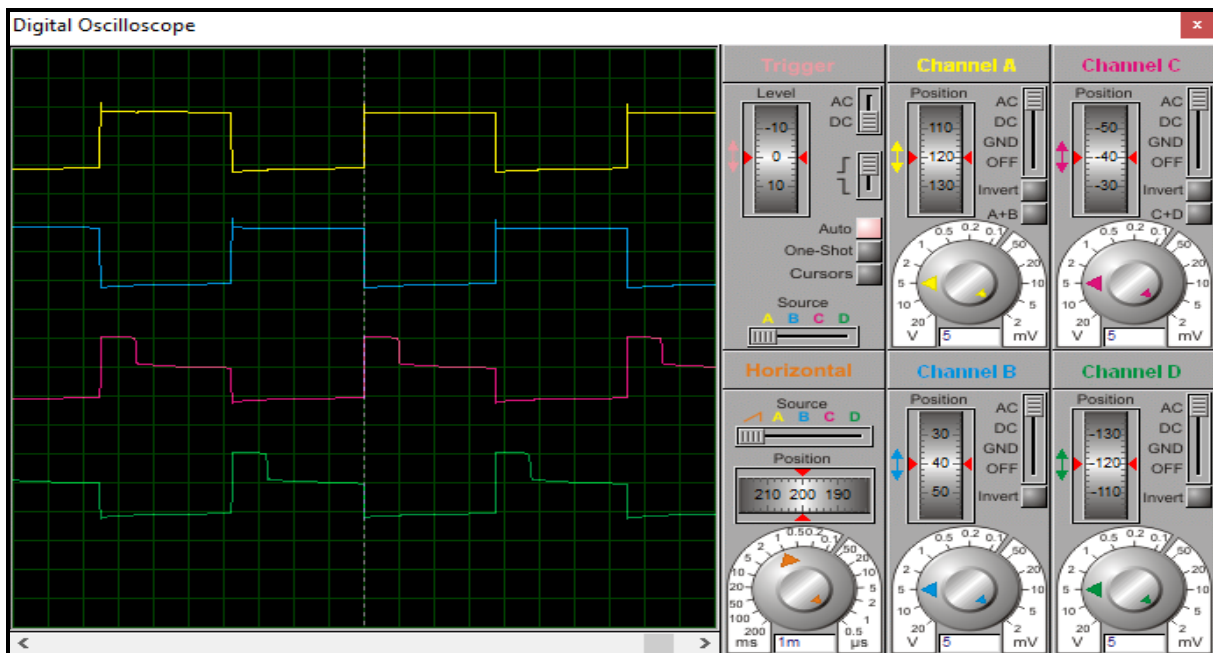

Figure - 6: PWM Output without Bridge Fault

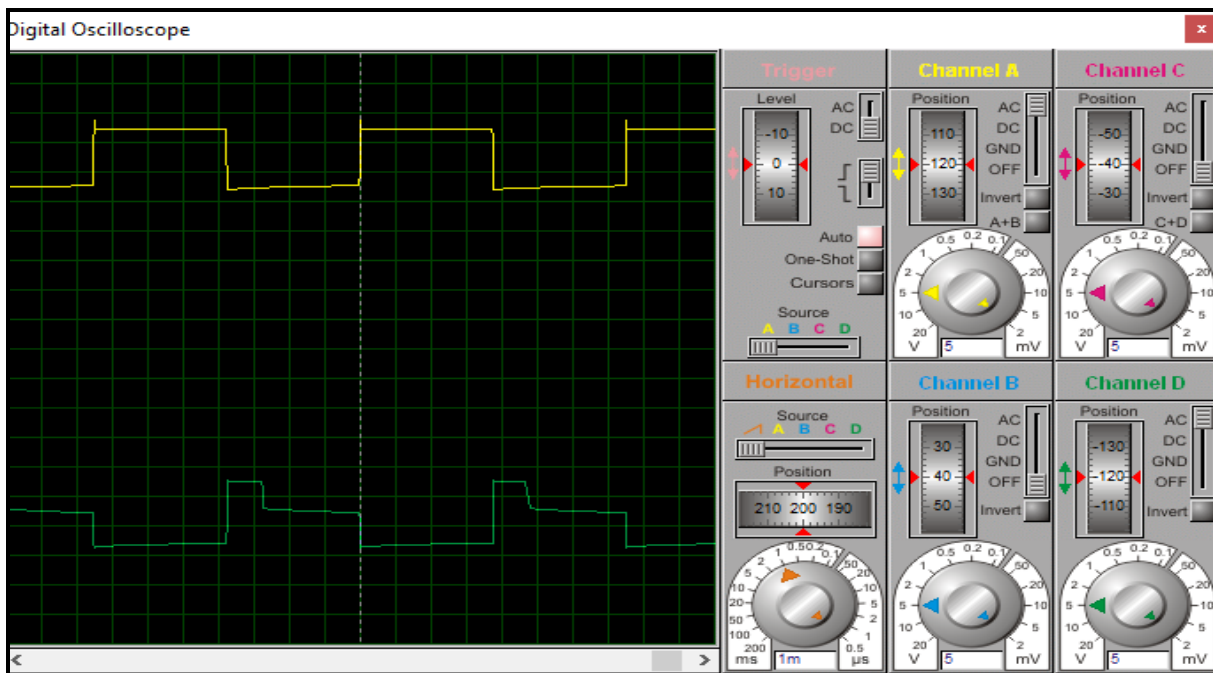

Figure-7: Transistor (Q1; Q4) is on, Transistor (Q2; Q3) is off

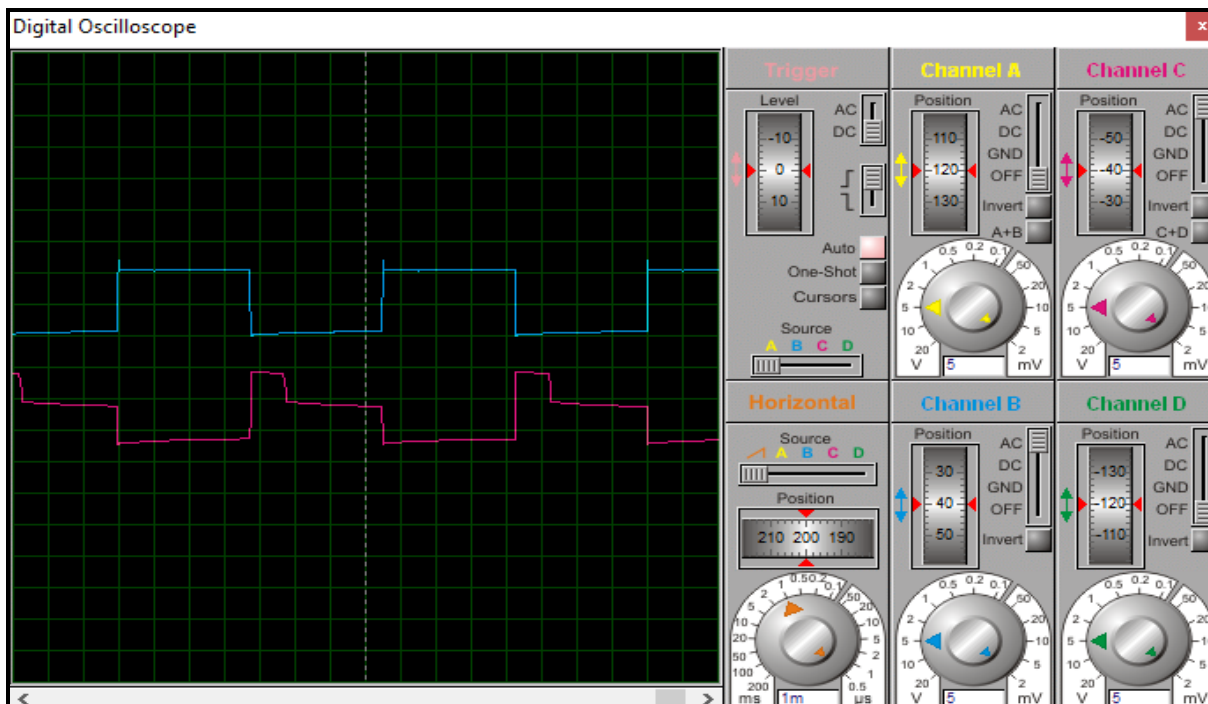

Figure-8: Transistor (Q2; Q3) is on, Transistor (Q1; Q4) is off

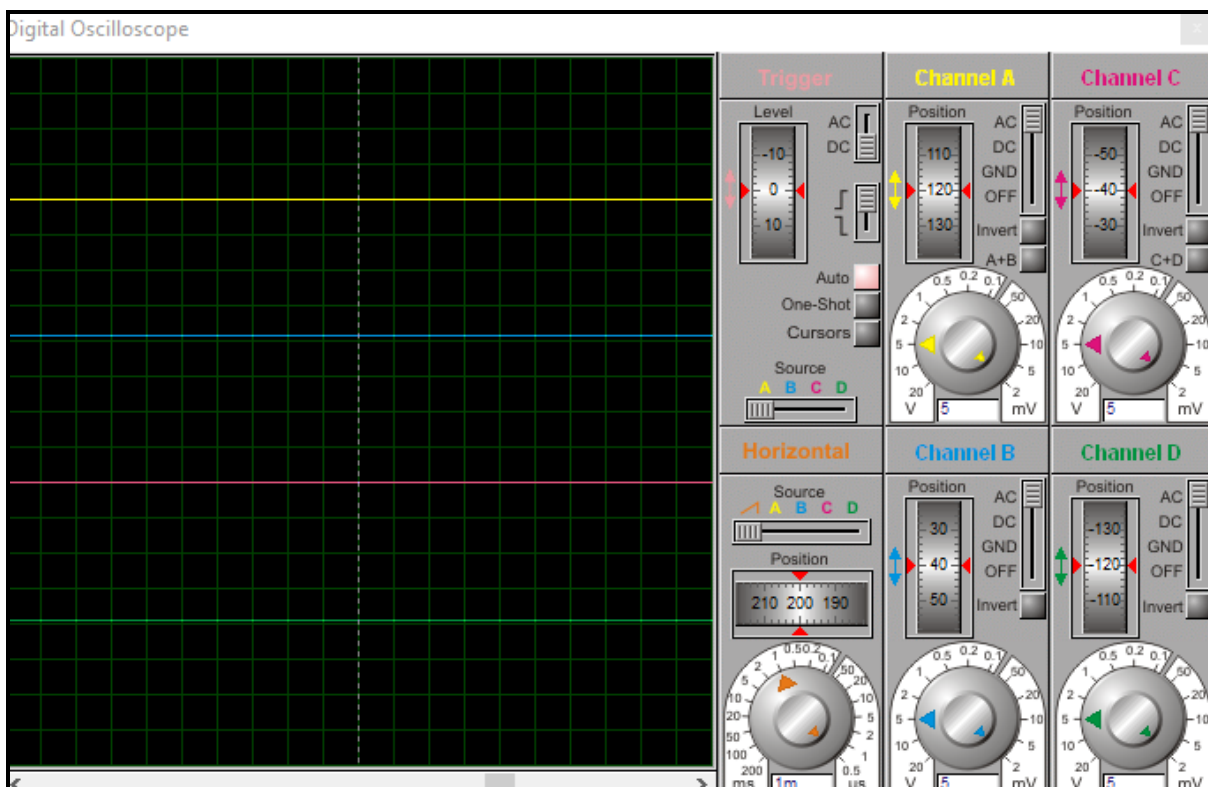

Figure - 9: Bridge Fault occur Output becomes Zero Potential

## 5. CONCLUSION

A high frequency power inverter is successfully designed by using STM32F103C6 PWM Control IC with IR2104 Gate Driver Ic. Inverter fault problems are raised, analyzed, and deducted. One of the solutions to prevent the faults is to render fault deduction circuit with automatically stopping the power transfer. The proposed concept has the potential to Produce a single-phase high-frequency AC voltage of 15V (for experimental purposes) at a frequency of 110KHz.

## 6. FUTURE SCOPE

In future research can be done to increase the distance by considering different parameters such as the frequency transmitter and the size of the receiver coil. There is also the possibility of doing work to improve production. Both electronic devices such as phones laptops and implantable devices will be charged concurrently in the future and work will be able to incorporate multiple outputs from the same transmitter coil. It would be more effective, so it could decrease the energy crisis.

## REFERENCES

- [1] Alanson P. Sample, Benjamin H. Waters, Scott T. Wisdom, Joshua R. Smith, "Enabling seamless wireless power delivery in dynamic environments," Proceedings of the IEEE, vol. 101. no 6, pp.1343-1358, June 2013.
- [2] M. Pinuela, et al., "Maximizing DC-to-Load Efficiency for Inductive Power Transfer," IEEE Transactions on Power Electronics, vol. 28, no 5, pp. 2437-2447, May 2013.
- [3] Muhammad H. Rashid, "Power electronics: circuits, devices, and applications", 3rd ed. 2004, Pearson/Prentice Hall. (Book)
- [4] STMicroelectronics, "Low-density performance line, ARM-based 32-bit MCU with 16 or 32 KB Flash, USB, CAN, 6 timers, 2 ADCs, 6 com. Interfaces," STM32F103x4 Datasheet, June 2015.
- [5] International Rectifier, "Half-Bridge Driver," IR2104 Datasheet.