

Solar Powered Automatic Railway Track Fault Detector using MPPT with Flood and Landslide Detection with IP Camera Surveillance using IOT

Aditi Shukla¹, Alpna Xalxo², Amruta Nema³, Deeksha Yadu⁴, Mousam Sharma⁵

¹⁻⁵Dept. of Electrical and Electronics Engineering, Bhilai Institute of Technology, Durg, C.G., India

Abstract: In India majority of the railway tracks have been improved with the latest technology. Accidents may occur due to some mechanical error, but often due to human error. Even then lot of train accidents are occurring due to crack in the railway track due to which many people are losing their lives. Also sometimes due to problem in the signaling train collision have also been occurring. Because of the fast development in advanced technology, many devices have been developed to detect and avoid the accident due to crack railway track and train collision. This paper is aimed towards addressing the issue by developing an automatic railway track crack detection system. This work introduces a project that aims in designing robust railway crack detection scheme which avoids the train accidents by detecting the cracks on railway tracks. And also capable of alerting the concerned authorities in the form of messages along with location by using IOT. The system also includes distance measuring sensor which displays the track deviation distance between the railway tracks.

Keywords: Railway Track, Fault Detection, Solar Powered, IOT

I. Introduction:

In India and lot of people prefer railway as their medium of transport. Because of this much technological advancement have been carried out to improve the railway transportation. Since railway is the major transportation medium and spread over in all over the India, it needs proper maintenance. Without proper maintenance it is difficult to avoid accidents in railway. Now-a-days lot of technological development have been done to improve the railway department. The major difficulty has been the lack of cheap and efficient technology to detect problems in the rail tracks and of course, the lack of proper maintenance of rails which have resulted in the formation of cracks in the rails and other similar problems caused by antisocial elements which jeopardize the security of operation of rail transport. In the past, this problem has lead to a number of derailments resulting in a heavy damage of life and assets. Cracks in rail have been identified to be the main cause of derailments in the past, yet there have been no cheap automated solutions available for testing purposes.

II. Proposed System:

Our system is designed in such a way that the solar power is used for energizing the whole unit. The MPPT technique is used to maximize power extraction under all conditions. To carry on the procedure a DC to DC converter is implied. The IR sensor detects the obstacle and the crack that comes in the track. The flood is sensed by the ultrasonic sensor and the landslide is detected by the probes placed in the model. All the modules are connected with the microcontroller to control their actions. As any of the above mentioned problem occurs the location is sent to the respective numbers through message by the GSM and the GPS system. The notification from the IOT module of the disturbances goes to the respective module. The detailed information about each of the module is described below.

This system involves the design of crack finding device for finding cracks in railway tracks. This system uses controller for interfacing the robotic vehicle and crack detection sensor. The sensing device senses the voltage variations from the crack sensor and then it gives the signal to the

microcontroller. The microcontroller checks the voltage variations amid measured value and threshold value and controls the robot according to it. The model is interfaced with the microcontroller with the help of motor driver circuit. If any crack occurs in the rail, the device will detect it and then a message will be send.

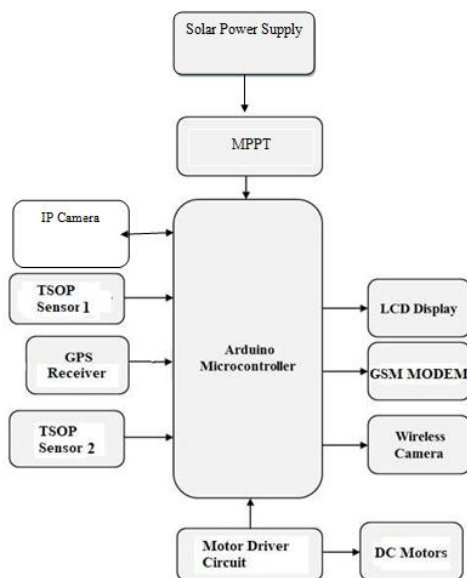

Figure 2.1: Block Diagram

In this system we have interfaced two TSOP IR sensors with the microcontroller for the distance and detection of the crack present in the track of the railway line. A GPS receiver is also interfaced with the microcontroller to determine the precise location of the crack on the railway track. This GPS receiver will provide the longitude and latitude parameter values to the controller. A wireless IP based camera is also used in this system. This camera is interfaced in the system for live issuing of the status of the railway track. This camera provides the live video to the device in which the application of that camera is installed. The design of the proposed system also consists of a 16x2 LCD display, interfaced with the microcontroller for the display purpose. This LCD display will display the longitude and latitude values of the crack detected by the system.

The proposed system uses multiple sensors for railway application. It consists of IR sensor, ultrasonic sensor and touch sensor. The IR sensor will sense the

crack in the railway track. If it detects, then this system updates the crack detected information to the IoT website and stops the train slowly. The ultrasonic sensor will notice the obstacle in front of the train. If it detects, then the information will be updated to the IoT website and it slows down the train. All the status from the sensors will be updated to the specific IoT website. The train can also be stopped through the IoT. To stop the train manually we can use IoT.

When a crack is detected by the IR sensor the vehicle stops at once, and the GPS receiver triangulates the position of the vehicle to receive the Latitude and Longitude coordinates of the vehicle position, from satellites. The Latitude and Longitude coordinates received by GPS are converted into a text message which is done by microcontroller. The GSM module sends the text message to the predefined number with the help of SIM card that is inserted into the module.

IP Camera: IP cameras are Closed-circuit television (CCTV) cameras that use Internet Protocol to transmit image data and control signals over a Fast Ethernet link. As such, IP cameras are also commonly referred to as network cameras. IP cameras are primarily used for surveillance in the same manner as analog closed circuit television. A number of IP cameras are normally positioned together with a digital video recorder.

TSOP Sensor: The TSOP-OBSD-Single is a general purpose proximity sensor. Here we use it for collision detection. The module consist of a IR emitter and TSOP receiver pair. The high precision TSO receiver always detects a signal of fixed frequency. Due to this, errors due to false detection of ambient light are significantly reduced. The module consists of 555 IC, working in astable multivibrator configuration. The output of TSOP is high whenever it receives a fixed frequency and low otherwise. The on-board LED indicator helps user to check status of the sensor without using any additional hardware. The power consumption of this module is low. It gives a digital output and false detection due ambient light is low.



Figure 2.2: TSOP Module

TSOP based IR Sensor a modulated IR light at selected frequency is transmitted and a receiver is made that would only detect light of the same frequency, filtering out light of other frequencies.

MPPT: Maximum power point tracking (MPPT) controllers play an important role in photovoltaic systems. They maximize the output power of a PV array for a given set of conditions. This paper presents an overview of the different MPPT techniques. Each technique is evaluated on its ability to detect multiple maxima, convergence speed, ease of implementation, efficiency over a wide output power range, and cost of implementation. Here a DC to DC converter is used to achieve Maximum power point tracking.

Flood and Landslide Detection: Ultrasonic sensor along with the probe will be used for flood and landslide detection. Ultrasonic waves are sounds with frequencies higher than 20 kHz which is not heard by humans. The theory is based on measuring the pulse reflection time. The ultrasonic transducer transmits a wave pulse and receives a reflection signal called echoes. When the transmitted wave pulse detects an object, the reflected wave, echo wave, is bounced back to the transducer.



Figure 2.3: Ultrasonic Sensor

At Normal Condition: The IR transmitter sensor is transmitting the infrared rays. These infrared rays are received by the IR receiver sensor. The Transistors are used as an amplifier section. At normal condition Transistor is OFF condition. At that time relay is OFF, so that the device examine continuously. **At Crack Condition:** At crack detection conditions the IR transmitter and IR receiver, the resistance across the Transmitter and receiver is high due to the non-conductivity of the IR waves. When the track is in continuous without any cracks then output of IR LED and Photodiode will be high. As soon as the crack detected by the system the TSOP sensor reflection will be equal to zero and the robot will be stopped automatically. Another TSOP sensor is used to monitor the pit on the way of the railway track. When this output is high then it is concluded that there is no pit in the track. But if any pit is detected by the sensor the output of the sensor given to the microcontroller will be zero and again the microcontroller will stop the robot. When a crack is detected by the IR sensor the device stops at once, and the GPS receiver triangulates the position of the device to receive the Latitude and Longitude coordinates of the vehicle position, from satellites. The IOT module sends the text message.

Receiving Circuit:

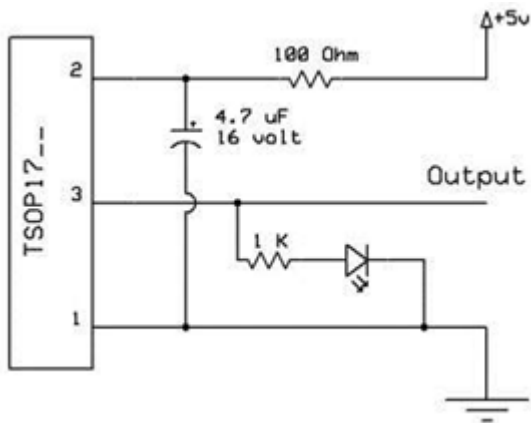

Figure 2.4: Receiving Circuit

In the above circuit 100Ω resistance and 4.7μF is connected to suppress power supply disturbances. An LED is connected at the output pin of TSOP to indicate the logic level.

Transmitting Circuit:

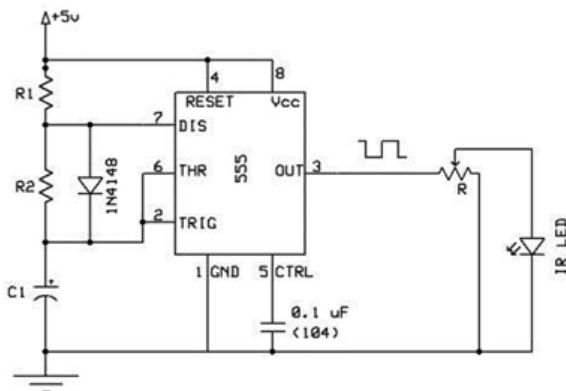

Figure 2.5: Transmitting Circuit

GPS Module: Global Positioning System (GPS) satellites broadcast signals from space that GPS receivers, use to provide three-dimensional location (latitude, longitude, and altitude) plus precise time. GPS receivers provides reliable positioning, navigation, and timing services to worldwide users on a continuous basis in all weather, day and night, anywhere on or near the Earth.



Figure 2.6 GPS Module

GSM: This GSM Modem can accept any GSM network operator SIM card and act just like a mobile phone with its own unique phone number. Advantage of using this modem will be that you can use its RS232 port to communicate and develop embedded applications. Applications like SMS Control, data transfer, remote control and logging can be developed easily.



Figure 2.7: GSM Module

IOT: The Internet of things refers to a type of network to connect anything with the Internet based on stipulated protocols through information sensing equipments to conduct information exchange and communications in order to achieve smart recognitions, positioning, tracing, monitoring, and administration. Internet of Things is a new revolution of the Internet. Objects make themselves recognizable and they obtain intelligence by making or enabling context related decisions thanks to the fact that they can communicate information about themselves. They can access information that has been aggregated by other things, or they can be components of complex

services. This transformation is concomitant with the emergence of cloud computing capabilities and the transition of the Internet towards IPv6 with an almost unlimited addressing capacity

III. Implementation and Result:

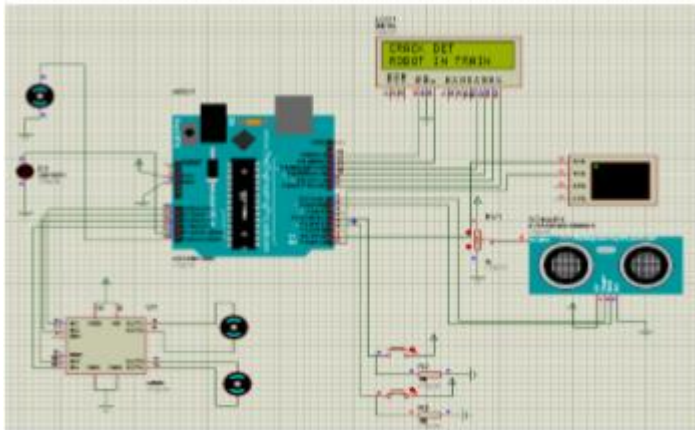

Figure 3.1: Initial Condition

At normal condition, the measured details are displayed at the LCD.

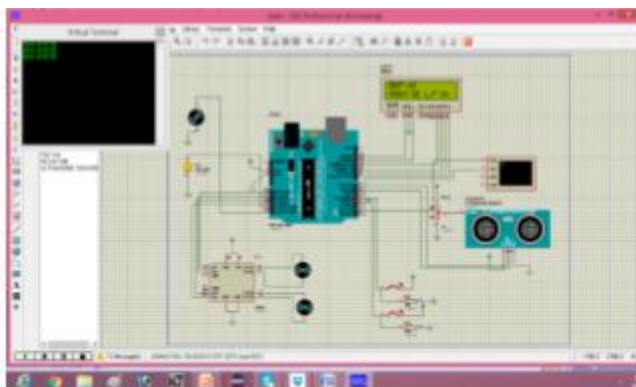

Figure3.2: Crack detection in the track

When the IR sensor detects the crack in the track, it stops the train slowly and the message is passed to the specific IoT website for further action.

IV. Conclusion:

Using this system when there is some obstacle present in front of the track or there is a presence of gap between two joining tracks, the IR sensor will detect the gap between the two tracks and indicate on Monitor display. With the help of Here Ir sensor detects the Gap between tracks and

ultrasonic sensor detects the distance between the train and the track where crack detected. If the train is getting near to the crack then Auto breaking system will apply and train will get stopped.

References:

1. César Briso-Rodríguez, Ke Guan, Yin Xuefeng "Wireless Communications in Smart Rail Transportation Systems", Volume 2017, Article ID 6802027, Oct.2017.
2. Ishan Jain, Shubham Malik and Soumya Agrawal, "Automatic Railway Barrier System, Railway Tracking and Collision Avoidance using IOT", International Journal of Computer Applications 175(8):13-16, October 2017.
3. Ganeshan P, Purushottam Shekhar, Ravi Shankar Shekhar "Automatic Detection of Squats in Railway Track", IEEE sponsored 2nd International Conference on Innovations in Information Embedded and Communication Systems ICIIECS"2015.
4. Anil Kumar Verma, Dharmendra Kumar, Gopal Krishna Gole, Jitendra Kumar, "Intelligent Train Engine for Fastest New Technology", International Journal of Innovative Research in Computer and Communication Engineering Vol.1, Issue 1, March 2013 ISSN(print): 2320-9798 ISSN(online):2320-9801.
5. Kawshik Shikder, "Intelligent System for Train Engine with Automatic Controlling Using Wireless Technology", International Journal of science and research(IJSR) ISSN (online):2319-7064 volume.
6. Archana A. Raut, Nisha S.Punekar "Improving Railway Safety with Obstacle Detection and Tracking System using GPS-GSM Model", International Journal of Science & Engineering Research, Vol. 4, Issue 8, Aug 2013.
7. Dibyayan Das Sharma, Sanjeev Kumar, Shweta Gupta "An Intelligent Train Engine Based on Auto-Signal Following Scheme Using IR Technology", The IUP Journal of

Electrical and Electronics Engineering, Vol. IV, No. 4, pp. 36-47, October 2011.

8. V. Kavitha, Maheshwari.M, "IOT Based Crack Detecting, Obstacle Detecting and Energy Minimizing Robot in Railway Track", International Journal of Innovations in Engineering Research and Technology [IJIERT] ISSN: 2394-3696 Volume 6, Issue 6, June-2019
9. Prof.S. B. Deokar, Ashwini D.Kadam, Neha D.Pachupate, Nilam D. Kudale. "IoT Based Railway Track Monitoring System using Ultrasonic Sensor", Open Access International Journal of Science and Engineering (OAIJSE), Volume 3, Special Issue 1, March 2018.
10. Keyur K Patel, Sunil M Patel, "Internet of Things-IOT: Definition, Characteristics, Architecture, Enabling Technologies, Application & Future Challenges", International Journal of Engineering Science and Computing, May 2016, DOI 10.4010/2016.1482 ISSN 2321 3361 © 2016 IJESC.