

Vibration Problem in Material Handling Plant and its Remedy

Subodh Chandra Pal¹, Partha Roy²

¹TENOVA DELKOR

²TATA Consulting Engineers Limited

Abstract - In today's world industrialisation is the sign of development of any country. Growths of heavy industries like steel plant, power plant, cement plant etc. are the sign of developed countries. The present paper mainly deals with the vibration problem in steel and concrete structure generated by dynamic equipments in the above said industries and its remedy.

Key Words: Vibration, frequency, damping, deflection, structure, foundation.

1. INTRODUCTION

Material handling plant is required in steel plant, power plant, mines, cement plant etc. Vibration is the major problem in material handling plant. In material handling plant some vibrating equipment are mounted on either concrete (RCC) building or, structural steel building. Vibration in structure beyond acceptable limit causes discomfort to the occupants. It also causes failure of structure.

The most difficult process in designing material handling building structure (concrete or, steel) is to calculate natural frequency of the structure as the material handling equipment manufactures do not supply the correct vibrating load in most of the cases. For that it becomes troublesome for a civil / structural engineer to determine the frequency level of the equipment, which in turn causes vibration in the building. Apart from that it is also noticed that the vibration isolation system is not properly designed / supplied. Rubber pad used below vibrating equipment starts malfunctioning after sometimes when it dries out. Similarly, the spring below vibrating equipment starts malfunctioning after some times when it chokes due to industrial dust.

2. VIBRATION ANALYSIS

Vibration in concrete and steel structure is different and solving of vibration in steel structure is different with concrete structure.

In material handling plant, generally screen, vibro feeder, crusher, motor etc. are main vibration creating equipment. It is advisable to install crusher on a concrete structure instead of steel structure.

For calculating floor vibration in steel structures, there are different methods of analysis. Most popular of them is Dunkerley's method. In this method the fundamental system frequency f_0 is determined as below -

$$\frac{1}{f_0^2} = \frac{1}{f_1^2} + \frac{1}{f_2^2} + \frac{1}{f_3^2} + \dots$$

Where, f_1 , f_2 and f_3 are component frequencies, unit of which is Hz (Hertz = cycles/sec).

From the above equation the fundamental system frequency is derived as below -

$$f_0 = \frac{1}{\sqrt{\left(\frac{1}{f_1^2} + \frac{1}{f_2^2} + \frac{1}{f_3^2} + \dots\right)}}$$

$$f = \frac{1}{2\pi} \sqrt{\frac{g}{y_w}} = \frac{18}{\sqrt{y_0}}$$

In the above equation weighted average value of deflection considered as $y_w = \frac{3}{4}y_0$. In the equation the unit of y_0 is the maximum short-term deflection in mm resulting from loads self-weight of structure and other loads.

The simplified method of deriving short-term deflection (y_0) at centre of simply supported beam is furnished below -

a) For uniformly distributed load (w) -

$$y_0 = \frac{5 w L^4}{384 E I} = \frac{5 W L^3}{384 E I}$$

Here, $W = (w L)$

- b) For a point load (P) acting at a distance “a” from left support –

$$y_0 = \frac{P L^3}{48 E I} \left[\frac{3a}{L} - 4 \left(\frac{a}{L} \right)^3 \right]$$

Where, L = Span of beam,

E = Young’s modulus,

I = Second moment of inertia

A sample example described below –

In a screen building in screen floor a vibrating screen of mass 3000 kg (30 kN), 900 rpm (900 / 60 = 15 cycles/sec or, 15 Hz) is mounted on 4 locations (load in each point = (30 / 4) = 7.5 kN = 7500 N). Out of 4 locations 2 locations of screen support is as below –

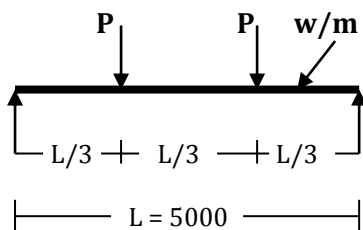

The screen is supported on a beam section of ISMB 450 of self weight (w) 72.4 kg/m (total UDL 747.4 kg / m including beam self weight) and moment of inertia (I) = 45218 cm⁴. Now deflection -

$$y_1 = \frac{5 w L^4}{384 E I} = \frac{5 (7.474)(5000)^4}{384 (2 \times 10^5) (45218 \times 10^4)} = 0.571 \text{ mm.}$$

$$y_2 = \frac{23 P L^3}{648 E I} = \frac{23 (7500) (5000)^3}{648 (2 \times 10^5) (45218 \times 10^4)} = 0.367 \text{ mm.}$$

From the above $f_1 = (18 / \sqrt{0.571}) = 23.81 \text{ Hz}$ and $f_2 = (18 / \sqrt{0.367}) = 29.67 \text{ Hz}$, $f_0 = \sqrt{[1 / \{(1 / 23.81^2) + (1 / 29.67^2)\}]} = 18.57 \text{ Hz}$ which is close to screen frequency 15 Hz, which is not desirable.

Now if the screen is mounted on spring with a spring rate 150 N/mm, stroke 10 mm and angle 15 degree. Then vertical component = (10 Cos 15) = 9.659 mm (4.829 mm each) Then impressed force = (150 x 4.829) = 724.44 N, for which $y_2 = 0.036 \text{ mm}$ and $f_2 = 95.48 \text{ Hz}$. For $f_1 (23.81 \text{ Hz})$ and $f_2 (95.48 \text{ Hz})$, $f_0 = 23.11 \text{ Hz}$, which is away from screen frequency of 15 Hz and (23.11 / 15) =

1.54 times of screen frequency (less than 2.0). Viscodamper is better solution instead of spring.

Despite vibration calculation (sometimes vibration calculation ignored also) it is found that the steel structure vibrates. Then the structural engineer rectifies the structure by strengthening beam (welding plate or, half cut beam / “T” section on bottom flange of beam) and column (welding plate or, half cut beam / “T” section on column flanges or web). Similarly concrete structures also strengthened by column jacketing etc.

Steel structure experience to vibration, low to high impact as well as fatigue load, it is better to consider welding over bolt. Though bolting and welding may able to provide unified structure, but materials that are welded can better withstand. Bolted joints have damping ratio 2 to 3 times higher than welded joints. Welded joints are more rigid than bolted joints due to continuity of cross-section. On the other hand bolted joints are connected with plates or, angles and deflection of these elements during load transfer adds flexibility as bolted joints allow some movement than welded joint.

3. HUMAN FACTOR IN FLOOR DESIGN

If any steel building is also used as office then the building to be checked for occupants comfort level.

Floors for high natural frequency (fundamental natural frequency exceeds 7 Hz) –

$$R = \frac{30000}{m b_c L}$$

Floors for low natural frequency (fundamental natural frequency less than 7 Hz) –

$$R = \frac{68000 C_f}{m S L_{eff} \zeta}$$

Where, C_f = Fourier component factor taken as function of floor frequency f_0 (Hz),

M = Floor mass (kg/sqm) including occupancy load,

L_{eff} = Floor beam effective span (m),

S = Floor effective width (m),

ζ = Critical damping ratio (structural damping)

The above calculated response factor (R) shall be within acceptable limit (general office R = 8, special office R = 4 and busy office R = 12)

4. CASE STUDY

Some case study furnished below –

CASE - 1

A vertical compressor of weight 1.8 T was installed in centre of a room of size 5 m x 4 m. A river was 650 m away from site. Compressor was installed on a concrete block foundation of size 2.0 m (L) x 1.5 m (W) x 1.5 m (D). Within few minutes after starting the compressor, the block foundation sank around 120 mm below floor level. After investigation it was found that the soil was sandy silt and compressible. Due to close vicinity of river, the soil was saturated and pore water pressure increased, which cause liquefaction of soil and due to this foundation sank. Then new location selected away from river, where 3 m x 3 m area excavated upto 1.8 m depth. Sal wood (80 mm to 100 mm dia and 2000 mm length) piling done @ 300 mm C/C. Over this a raft of

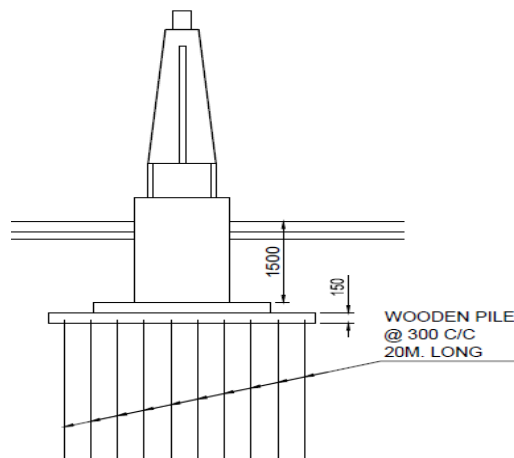

FIG. - 1 : Rectified Foundation

2.5 m x 2.5 m x 0.3 m constructed. Block foundation of size 2.0 m x 1.5 m x 1.5 m (D) was constructed over raft to install machine. Then the vibration measured which was within acceptable limit.

CASE - 2

In a coal washery steel building two (2) nos high speed vibrating screen of weight 5.25 T and 1200 rpm was installed at 9.50 m level. The building was analysed with all equipment loads using software. Modal analysis

performed and natural frequency was kept far away from mode shape frequency (cut-off mode shape was 12). During cold commissioning the screens generated vibration in the building. Horizontal displacement measured at 9.50 m level was 16 mm. After thorough investigation it was found that the building analysis was perfect but the centrifugal force supplied by equipment manufacturer was wrong (designed for 7.5 T each, which should be 12.0 T each). Uncounted force was $[2 (12.0 - 7.5)] = 9 T$ with 1200 rpm, which produces an uncounted horizontal force of $(9.0 \cos 45^\circ) = 6.36 T$. Then the building was redesigned and elevation bracings were introduced in some panels. As suggested by equipment manufacturer, the metal spring was replaced by rubber buffer support.

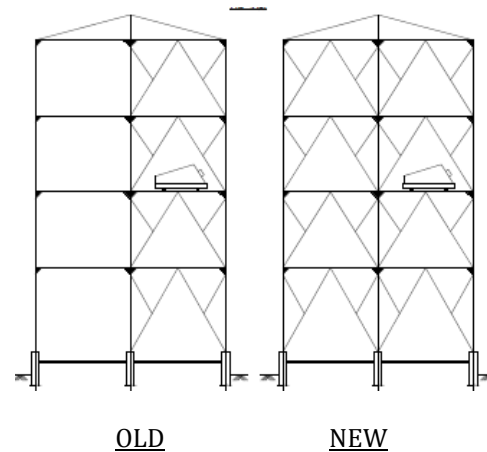

FIG. - 2 : Steel Building (Before & After Rectification)

Metal coil spring absorbs around 46 % vibrating energy, whereas the rubber buffer absorbs around 90 % of vibrating energy. After these modifications vibration in buildings was arrested.

CASE - 3

In an iron washery project a centrifuge of 3.5 T was mounted on a steel supporting frame. Forces F_x , F_y and F_z were furnished in equipment drawing. Equipment manufacturer suggested a clear gap of 40 mm around the centrifuge supporting structure. Supporting structure was designed with 3 times load of equipment manufacturer's load. A clear gap of 60 mm maintained around the supporting structure. During cold commissioning the supporting structure along with foundation started vibrating and it started striking adjacent structures. Displacement recorded at site was approx. 75 mm. It was concluded that the vibration was

developed due to excessive horizontal force developed by equipment, which was uncounted in design.

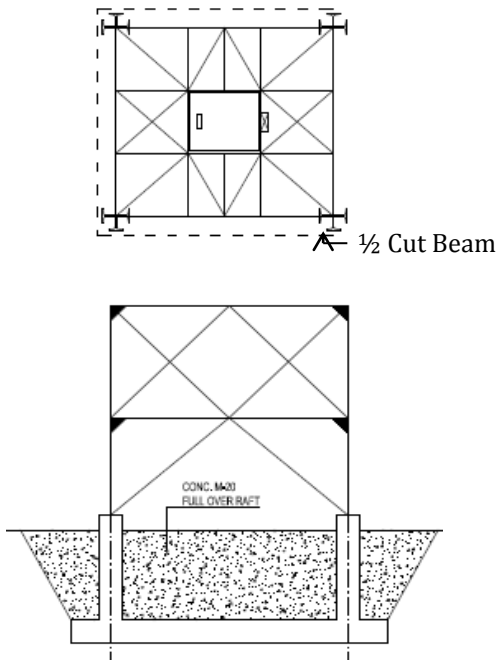

FIG. – 3 : Steel Structure & Fdn. After Rectification

The structure was modified by providing additional half cut beam in column web and erecting new vertical bracing in all four sides. In foundation soil over raft was removed and concrete was poured with minimum reinforcement. Pedestals were tied with new tie beams. Sufficient time was given to concrete to gain strength. Hot commissioning conducted and found that the vibration was within limit.

CASE - 4

In an iron ore washery plant, two slurry handling pump (90 kW), each of 900 rpm was installed on block foundation at founding depth of 1.50 m in two different buildings. Both the foundation was founded over a fill of iron ore overburden of 1.50 m. After commissioning it was observed that the first pump foundation, which was located inside a washery building operating within vibration limit, but the second pump foundation, which was located in different building tilted after some time. After thorough investigation it was noticed that the backfilling of first foundation was done in layers (300 mm each) with 95 % Proctor density. But in the second foundation, the backfilling was not done properly. The second foundation dismantled and the block foundation

placed over a PCC fill of 1.50 m and the vibration of second foundation was arrested.

CASE - 5

In a ball mill foundation there were two numbers Trunion bearings fixed with foundation block. Each Trunion bearing was fixed with block foundation by four nos M-72 x 2100 mm long foundation bolt. Grade of foundation block was M-30. After curing of concrete the foundation bolt was tested for bolt tension of 70 T as per equipment manufacturer's specification. When the full torque was applied the concrete pedestal cracked from 1.0 m top of raft. It was noticed that out of four foundation bolts two bolts were not true plumbed i.e., vertical alignment was faulty. When tension applied on these two bolts crack generated in the pedestal. Then the pedestal portion demolished and pedestal constructed applying concrete bonding agent. Special care was taken for the vertical alignment of the foundation bolt. Once again tension in bolt checked and found OK. Machine is working fine in new foundation.

CASE - 6

In a steel building, a crusher was mounted on a table type framed concrete foundation. After commissioning it was noticed that the steel building along with the crusher foundation was vibrating. After investigation it was found that the rubber pad was dried out. Then the crusher manufacturer redesigned the rubber pad and supplied good quality pad as per revised design. Steel stair from building which was rested on crusher foundation deck slab was also separated from crusher foundation to restrict the transmission of vibration from crusher foundation to steel building. After these the vibration in crusher foundation and steel building lowered down within acceptable limit.

CASE - 7

In a steel building (screen house) after commissioning of screen at higher level, a large amount of vibration was noticed in the building. After thorough investigation it was found that the screen loads supplied earlier by the screen manufacturer was in lower side. The steel building was redesigned with new loads of screen supplier. Half cut "I" beams welded with the middle four columns of the building to form star column, where the screen was mounted. Half cut "I" beams welded below the bottom flange of interconnected beams carrying the

screen. In all the floors, specially in screen floor some additional floor bracings were provided along with some elevation bracing in outer bays in some selected areas.

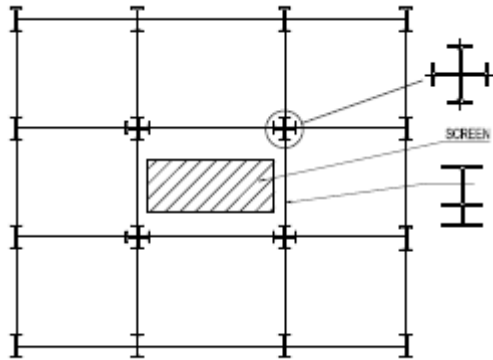

FIG. – 4 : Beam and Column Modification work

After these modifications the vibration in the building was arrested within acceptable limit.

CASE – 8

In a steel building a high capacity crusher was mounted on a table type concrete foundation. Same experience was observed as case – 7. Same type of rectification work conducted as case – 7. Additionally the crusher foundation frame columns were tied by diagonal steel bracing with the help of HILTI bolt. After modification the vibration was noticed under acceptable limit.

5. RECOMMENDATIONS

It is better to keep following points before commencing of engineering and construction / erection of vibration supporting structures / foundations -

- It is better to ensure the static and specially the dynamic loads from equipment manufacturer,
- In absence of proper load data, the load to be increased by dynamic load factor. The dynamic load factor to be judged properly,
- Soil investigation report with dynamic property of soil is required. In absence of shear wave velocity and dynamic properties, static analysis done.
- Natural frequency of any machine foundation should not preferably within 20 % of the operating frequency of machine,
- The eccentricity of the combined centre of gravity of the foundation and machine w.r.t. the

centroid of foundation base area should not exceed 5 % of the dimension of the base in each plan direction,

- It is also required to check vibration amplitude, which should be within prescribed values,
- Bearing capacity to be checked in dynamic loads also. It is better to reduce allowable bearing capacity of soil during SBC check. In general it is better to reduce allowable bearing capacity of soil by 20 %. (low RPM machine 0 %, medium RPM machine 10 %, high RPM machine 20 %, crusher / hammer 30 %)
- High stiffness of members will help to avoid vibration, but excessive use of oversized beams will affect the mass and cost,
- Shortening of beam / girder span is very effective in reducing vibration in building / structure,
- Arrangement of proper bracing system (both in plan and elevation) is required in steel structures,
- Strict supervision required in steel structure for welded and bolted connection,
- If there is more than one source of vibration in a floor, then it is better to restrict transfer of vibration from one part to other by placing a joint in floor.
- A tuned mass damper (TMD) can significantly increase the damping ratio of a floor at the natural frequency which can drastically reduce the velocity and acceleration of the floor system at that frequency,
- Adding mass to the floor system reduce the vibration at resonance. But addition of mass also lowers the fundamental frequency of floor.
- Using star section or at least wide flange I section / H beam in columns provide better result in vibrating structures,
- Isolation of vibration equipment like crusher by providing separate table type foundation and no connectivity between Steel building and crusher foundation is better solution to restrict vibration in structure,
- Proper isolation below equipment support is required as in many case under designed vibration pad / spring is used,
- Using vibration damper below vibrating equipment is also provides better result in vibrating structures. Viscodampers perform better than spring or, rubber type damper as

rubber pad dries out after sometime and spring chokes due to industrial dust. Viscodampers are visco-elastic elements active in all degrees of freedom. The damping forces are proportional to the relative velocity between the piston (top part) and the housing (bottom part),

- s) In isolated concrete beam, supporting dynamic equipment elastomeric bearing pad can be used at support to reduce the vibration of concrete beam,
- t) In steel structure it is better to adopt concrete floor over steel supporting beams in crusher and screen floors,
- u) For table type concrete frame foundation, it is better to adopt concrete wall type framing (at least in two sides) than concrete column type frame structure in case of jaw crusher,
- v) Proper alignment of machine is required,
- w) Proper anchor bolt design and proper alignment of foundation bolt is also very important to arrest unwanted vibration,
- x) Good quality construction, fabrication and erection under strict supervision are also one of the most important factors.

- (4) W.T. Thomson, Theory of Vibration with Applications,
- (5) J.S. Rao and K Gupta, Theory and Practice of Mechanical Vibrations,
- (6) INSDAG, Design Guide on the Vibration Floors

BIOGRAPHIES

Subodh Chandra Pal (ME, Civil)



He has vast experience in Design Engineering in Concrete and Steel Structures. He served companies like HUMBOLDT WEDAG India, INGWENYA Mineral Tech Pvt Ltd., CALCOM Cement India, TENOVA DELKOR.

Partha Roy (ME, Civil)



He has wide experience in Civil and Structural design of Power Plant, Steel Plant and Material Handling plant. He is now working with TCE. He earlier served LAHMEYER, DANIELI, ESSAR Engineering, SANDVIK, TRF, AREVA.

REFERENCES

- (1) V.P. Singh, Mechanical Vibrations,
- (2) Anil K. Chopra, Dynamics of Structures,
- (3) Professor P.L. Ballaney, Theory of Machines and Mechanisms,