

# SMART ELECTRICITY MONITORING FOR HOME APPLIANCES

P.Hemanath Chowdary<sup>1</sup>, Ashok Kumar<sup>2</sup>, Prabhavathi K, Tejaswini B<sup>4</sup>,

Dr. B.S Sudharshan<sup>5</sup>, Professor

<sup>1-5</sup>Dept. of Electronics and Communication Engg., K S Institute of Technology, Bangalore, India

\*\*\*

**Abstract** - The idea of smart power monitoring using Arduino has been proposed. We are using Arduino because it is energy efficient i.e. it consumes less power, it is fastest. Monitoring and keeping tracking of your electricity consumption for verification is a tedious task today since you need to go to meter reading room and take down readings. AIM for the planning of a system which will minimize energy waste in home environments with efficiency managing devices operation modes. Automatic ON & OFF of appliances is possible.

**Key Words:** Watermarking, Haar Wavelet, DWT, PSNR

## 1. INTRODUCTION

The paper mainly deals with smart power meter, which utilizes the features of embedded systems i.e. combination of hardware and software in order to implement desired functionality. The paper discusses comparison of Arduino and other controllers. This system also can be used to disconnect the power supply of the house when needed.

Power saving and consumption using Microcontroller is building automation for a home called smart home which involves the control, consumption and automation of home appliances. The main aim of the project is to provide the consumer with a system which will provide the complete power consumption of the appliances used. The system will also implement home automation applications. Whenever there is an increase in the consumption of power by any of the home appliance, the system will keep a check of it. The advantage of the project is it will provide the user a complete overview of his power consumption

## 2. LITERATURE SURVEY

Asaad M. Al-Hindawi [1] presents new design of a smart energy meter integrated with a monitoring and control system to monitor the quality of electrical power supplied to consumer. But this deal with only for monitoring of quality of the power

Komkrit Chooruang [2] design and implement a low-cost energy monitoring system that can be used in many applications, such as electricity billing system, energy management in smart grid and home automation But it is designed for entire home application meter using wired network, we can't use it for individual appliances

N. K. Suryadevara [3] the design and development of a Smart Power monitoring device has reported in this paper. System has been designed that can be used to monitor electrical parameters such as voltage, current and power of household appliances

But it is designed for entire home application meter using wireless network, we can't use it for individual appliances [4] the use of smart home technology in the home or building offer significant potential for energy savings. In this paper we propose an energy management system based on wireless sensor network

Bilal Mubdir [5] this paper presents new design of a smart energy meter integrated with a monitoring and control system to monitor the quality of electrical power supplied to consumers and to protect them upon abnormal situations with the capability of storing all the events in real date and time as a history

In our project we are using Arduino Uno board in which power consumed is less when compared to others and Zigbee for transferring of the data which is cost efficient

Vinayaka Sonandkar [6] power measurement to reduce peak on generation by providing customers with their instantaneous power consumption. The aim of providing such data to the user is to encourage them to shift their load during non-peak hour and reduce their power usage and electricity bill

Valahia [7] represents a practical solution for a dynamic, affordable and flexible, power consumption monitoring system that is based on electrical sensors which are connected to the buildings own power grid. By using embedded technology and the internet of things concept we have prototyped a real time power monitoring system that is to be implemented in an autonomous smart home or building which uses renewable energy.

Jalpa Patel [8] most of the wastage units of power can be ceased by proper monitoring of usage. The proposed system uses magnetic induction principle to know the energy readings from one place of the house. The application notifies the users, which appliance is using more electricity and suggest some tips to monitor the electricity usage. If an appliance is not in use but still powered on, then the user can turn it off from a remote place

Sung-Yong Son [9] electricity consumption monitoring to understand energy consumption status and in this paper, a hybrid approach is proposed to improve energy consumption status estimation. Devices status information is shared via ubiquitous home networks in addition to the conversational energy consumption monitoring unknown devices. This approach makes the energy consumption inference more simple and accurate for the rest of

S.P.SGill [10] this system consists of a smart sensing unit that detects and controls the home electrical appliances used for daily activities results by following different tariff rates. It can reduce costs for the consumers and thereby improve grid stability. A developed photo type has been extensively tested and experimental have compared with conventional measuring devices

### 3. Proposed Algorithm

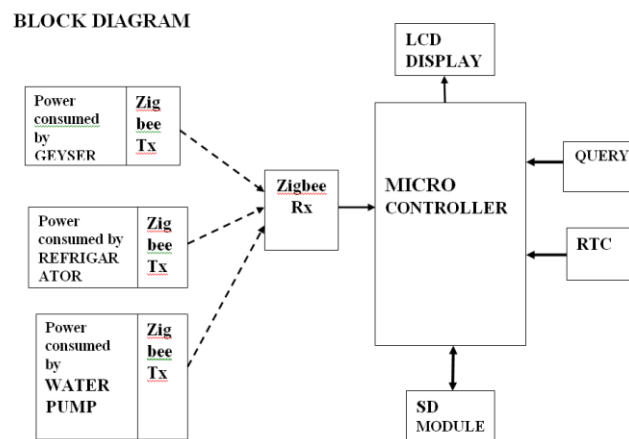

Monitoring and keeping tracking of your electricity consumption for verification is a tedious task today since you need to go to meter reading room and take down readings. Well it is important to know if you are charged accordingly so the need is quite certain.

The system by allowing users to monitor energy meter readings over the internet. These project proposes a low cost, secure, ubiquitously accessible, controlled solution for home automation. Looking at the current scenario we have chosen Android platform so that most of the people can get the benefit. The technology is easy to use and targeted for people without technical background.

Arduino board is the heart of our system. Entire functioning of system depends on this board. Arduino reacts to the 5v supply given by opto-coupler and keeps on counting the supply and then calculates the power consumed and also the cost. This data, it continuously stores on memory, so that users can visit any time and check their consumption. It even reacts accordingly as per programmed, to the situations like message sending during threshold value etc

Node MCU is one of the types of Arduino. It consists of ESP8266 Wifi module, and hardware which is based on the ESP-12 module. The term "Node MCU" is the core of this project. It is the intermediate between the user and the home appliances to be controlled. The main function of the node MCU is to create a web link through which the appliances can be controlled. The programming part is fed to the node MCU and it is stored in its memory for further use. This Arduino is cheap and very user friendly.

ACS712 is one of the types of current sensor. This is used to find the amount of current flowing through device. It is used for monitoring the current and provide it to the user on the given display. 5V DC supply is given to the ACS712 sensor as a power source. The power monitoring part of the system is carried out by using this sensor. They are easily compatible with the given Arduino board.

#### 4. CONCLUSION

An intelligent power monitoring and control system will be design and develop towards the implementation of smart house monitoring. The proposed system will monitor and control the electrical appliances usages at home. The sensor networks will be programmed with various user interfaces suitable for users of varying ability and for expert users such that the system can be maintained and interacted easily.

#### REFERENCES

- [1] Bilal Mubdir, Sabah Nasir Hussein, Asaad Al-Hindawi, Hussain Al-Rizzo, "Smart energy monitoring and control system based on wireless communication" ISSN:2249-8958, vol no. 3, Issue-1, October 2013
- [2] K.Chooruang and K. Meekul, "Design of an IoT Energy Monitoring System," 2018 16<sup>th</sup> International Conference on ICT and Knowledge Engineering (ICT & KE), Bangkok, 2018, pp. 1-4.
- [3] Gill, S.P.S. & Suryadevara, Nagender & Mukhopadhyay, S.C.. (2012). Smart Power monitoring system using wireless sensor networks. Proceedings of the International Conference on Sensing Technology, ICST. 444-449. 10.1109/ICSensT.2012.6461718.
- [4] Kim, Woong & Lee, Sunyoung & Hwang, Jongwoon. (2011). Real-time Energy Monitoring and Controlling System based on ZigBee Sensor Networks. Procedia CS. 5. 794-797. 10.1016/j.procs.2011.07.108.
- [5] Sangeetha, C. Gomathi. R, T. Anne Ramya, "An iot based appliance control and monitoring system for smart homes", International Journal of Advanced Information in Engineering Technology(IJALET) Vol.5, No.5, May 2018, pp. 7-14
- [6] V. Sonandkar, A. Bhati, D. Gupta, S. Chouhan, N. Kinhekar and N. P. Padhy, "Power measurement using arduino for effective demand response," 2016 IEEE 6th International Conference on Power Systems (ICPS), New Delhi, 2016, pp. 1-5.
- [7] Miron Alexe, Viorel. (2017). Iot Power Consumption Monitoring System For Off-Grid Households. University of Pitesti Scientific Bulletin. 17.
- [8] Jalpa Patel, K. Avinash Reddy, M. Kirti, Dr. D. B. K. Kamesh, Dr. J. Sasi Bhanu, "Measurement Electricity Consumption Of Appliance and Monitoring Them Using IoT And Machine Learning," Vol no.05, Apr 4 2018, pp. 387-390.
- [9] Sung-Yong Son, "Home Electricity Consumption Monitoring Enhancement Using Smart Device Status Information," International Journal of smart home vol. 9, no.10, (2015), pp. 189-196.
- [10] Gill, S.P.S. & Suryadevara, Nagender & Mukhopadhyay, S.C.. (2012). Smart Power monitoring system using wireless sensor networks. Proceedings of the International Conference on Sensing Technology, ICST. 444-449. 10.1109/ICSensT.2012.6461718.