

Design & Analysis of Chassis of a Dual Seater All-Terrain Vehicle

Ritvij M. Shah¹

¹Final Year B.Tech Student, Dept. of Mechanical Engineering, Dr. V. K. MIT World Peace University, Pune, Maharashtra, India

Abstract - All-Terrain Vehicles (ATVs) available in the global market are used either by individuals for recreational and agricultural purposes or by defence personnel for military applications. To get engineers acquainted with this segment, various off-road motorsport competitions are organised in the automotive community, where the focus is on the single seater category of ATVs. However, this compact body style limits the scope of exploration of configurations for an ATV. Hence, production scale vehicles are offered majorly in a dual seater configuration as they provide more practicality. This configuration poses a challenge in designing of the chassis in terms of packaging, safety, weight and size. This paper provides a specific focus on the design and finite element analysis of the chassis of a dual seater ATV. Since ATV design is a vast domain, this paper refers to the designing guidelines mentioned in the rulebooks of Rally Car Design Challenge India and FSAE BAJA 800.

Key Words: All-Terrain Vehicle, ATV, Chassis, Finite Element Analysis, Material Selection, Roll Cage

1. INTRODUCTION

The chassis of a vehicle is the load-bearing framework, which structurally supports the vehicle and all its components in their function. However, maintaining structural integrity of a vehicle is not the only function of a chassis. It is also the most important factor in ensuring the safety of the occupants of the vehicle, because chassis members are the first major point of contact in any collision. Therefore, selection of the construction material and the type of chassis is extremely important.

There are many different types of chassis like monocoque, ladder frame, space frame etc. A tubular spaceframe is a truss-like structure, which is strong because of the inherent rigidity of the triangular shape. Bending moments are transmitted as tension and compression loads along the length of each strut. For the purpose of building an ATV, a tubular space frame chassis proves to be more viable than a monocoque or a ladder-frame setup. One of the reasons for this is the lightweight and less complex construction of a space frame, which also provides easier access to other vehicular components. The other reason is that unlike the other types, space frames can be constructed without the use of advanced fabrication technologies. Space frames are constructed of metal tubes and are relatively easy to profile and join by welding.

1.1 Objectives of Design

- The roll cage must provide appropriate ergonomics and ensure safety of occupants of all sizes with compliance to adequate safety clearances.
- Quick and comfortable entry & exit from the vehicle should be possible for the driver & navigator, in case of an emergency.
- The chassis must accommodate the important components of the vehicle and provide accurate and strong mounting points for them.
- The frame must be designed such that the members of the chassis do not intrude with the wheels during steering and suspension travel.
- The chassis must allow for optimal handling and dynamic capability, while providing a strong and rigid structure, not easily prone to failure at any point.
- The chassis should handle and distribute Bending, Suspension & Impact loads efficiently.
- The chassis should be designed such that important components of the vehicle are easily accessible for repairs in case of any damage.

1.2 Steps in Designing & Analysis

1. Identification of basic requirements & design constraints.
2. Consideration of vehicle operating conditions & environment.
3. Identification of performance requirements.
4. Consideration of applicable constructional requirements.
5. Consideration of applicable stress for material selection.
6. Preliminary CAD of chassis.
7. Analysis of chassis design.
8. Final CAD of chassis based on the results of analysis.

The process of designing starts with the measurement of the dimensions of the occupants and considering optimum clearances in length, width and height of the roll cage.

2. MATERIAL SELECTION

Selection of material for chassis members is an extremely important step in the design process, because the physical properties of the material affect the safety and dynamic parameters of the ATV. Materials generally used in construction of a space frame chassis include different types & alloys of steel, aluminium, titanium and also carbon fibre composites. Exotic materials provide many advantages over steel in terms of physical properties but are extremely expensive, harder to procure and require special equipment for their fabrication. As a result, steel tubes are most commonly used for fabrication of a space frame chassis. Materials specified by American Iron & Steel Institute (AISI) should be used as they guarantee reliability and accuracy towards their stated physical properties.

The content of carbon present in a material hugely influences properties like machinability and weldability of a material. Higher carbon content in steel increases hardness and strength but also increases brittleness and reduces the weldability of the material. Lower carbon content equates to better machinability, weldability and higher ductility albeit with lower strength. Hence, seamless steel tubes having low carbon content i.e. between 0.18% to 0.3% should be preferred. It is important to select a grade of steel which attains the best compromise between strength, machinability and weldability. Considering all the necessary factors, AISI 1018 Low Carbon Steel & AISI 4130 Alloy Steel prove to be the optimum choices and are commonly used for this purpose.

Table -1: Material Properties Comparison

PROPERTIES OF MATERIALS		
ELEMENT PROPERTY	AISI 1018	AISI 4130
Carbon Content	0.14% - 0.20%	0.28% - 0.33%
Ultimate Tensile Strength	440 MPa	560 MPa
Yield Tensile Strength	370 MPa	460 MPa
Modulus of Elasticity	205 GPa	205 GPa
Poisson's Ratio	0.290	0.290
Elongation at Break (In 50 mm)	15%	21.50%
Brinell Hardness	126	217
Density	7.87 g/cc	7.85 g/cc

Standard suitable dimensions of AISI 1018 and 4130 steel tubes available in the market:

1. OD 38 mm & WT 2.5 mm.
2. OD 47.625 mm & WT 2.1 mm.
3. OD 50 mm & WT 2.0 mm.

To choose the better suited material, factors like weight, bending strength and bending stiffness must be compared to obtain optimum dimensions for the chassis tubes.

- Bending Strength = $\frac{\sigma_y \times I}{c}$
- Bending Stiffness = $E \times I$
- Moment of Inertia = $\frac{\pi}{64} \times (D_o^4 - D_i^4)$
- Weight/Unit Length = $\rho \times \frac{\pi}{4} \times (D_o^2 - D_i^2)$

Table -2: Selection of Cross Section: AISI 1018

Parameters	Diameter x Wall Thickness (mm)		
	38.1 x 2.41	47.625 x 2.1	50.8 x 2.1
Moment of Inertia (mm ⁴)	43220.75	77974.42	95427.35
Bending Strength (N-m)	839.458	1211.571	1390.083
Bending Stiffness (N-m ²)	8860.254	1598.476	1956.261
Weight per unit Length (Kg/m)	2.126	2.363	2.528

Table -3: Selection of Cross Section: AISI 4130

Parameters	Diameter x Wall Thickness (mm)		
	38.1 x 2.41	47.625 x 2.1	50.8 x 2.1
Moment of Inertia (mm ⁴)	43220.75	77974.42	95427.35
Bending Strength (N-m)	1043.650	1506.277	1728.211
Bending Stiffness (N-m ²)	8860.254	1598.476	1956.261
Weight per unit Length (Kg/m)	2.126	2.363	2.528

2.1 Observations

- Density of AISI 1018 is the same as that of AISI 4130, hence the weight per unit length of both the tubes is the same.
- It is observed that the bending strength of a 4130 tube is substantially more than that of a 1018 tube of the same dimension.
- Lesser wall thickness of tube reduces machining effort.

Considering all above factors, AISI 4130 proves to be the better choice of material and the following tubes are selected:

- Primary Members: 47.625 mm x 2.1 mm
- Secondary Members: 38.1 mm x 2.41 mm

3. COMPUTER AIDED DESIGN (CAD)

The idea for the design is to make the chassis suitable for a front mounted engine setup with a solid axle suspension at the rear, to aid in off-road prowess and equal weight distribution. The final design is created with chosen material and cross section, ensuring that all the design objectives are satisfied. SOLIDWORKS software is used for designing the chassis.

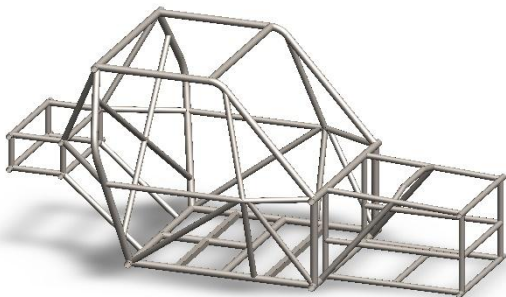

Fig -1: Dimetric View

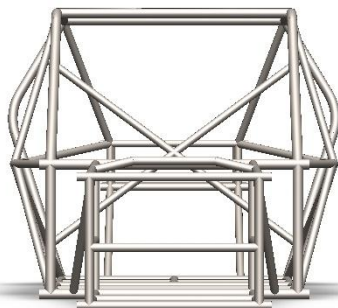

Fig -2: Front View

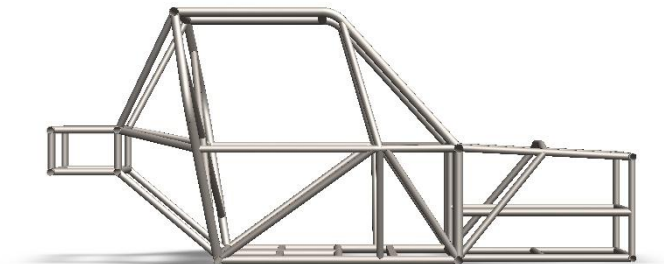

Fig -3: Side View

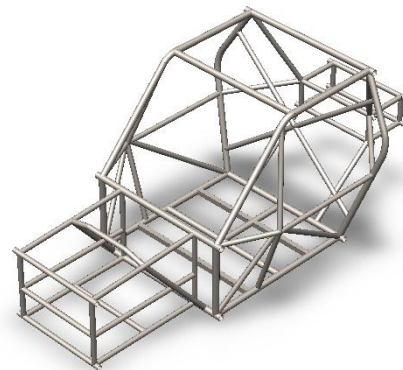

Fig -4: Isometric View

4. IMPACT FORCE CALCULATION

To determine the forces applicable on the vehicle chassis in case of impact, certain parameters of the vehicle must be fixed. Assumptions for calculation:

1. Weight of vehicle (with driver and navigator) = 500 kg
2. Maximum speed of vehicle = 65 km/h
3. Time duration of collision for frontal & rollover impact = 0.15 seconds
4. Time duration of collision for side impact = 0.20 seconds

4.1 Front Impact

Let W_{Net} = Net work done, F = Force, D = Displacement

$$W_{net} = \left| \frac{1}{2}mv^2_{final} - \frac{1}{2}mv^2_{initial} \right|$$

Final momentum after impact = 0

$$\therefore W_{net} = \left| - \frac{1}{2}mv^2_{initial} \right|$$

But, Work = Force x Displacement

$$W_{net} = F_{impact} \times D$$

$$\therefore F_{impact} = \left(\frac{1}{2}mv^2_{initial}\right) \times \frac{1}{D}$$

Displacement of vehicle after collision can be calculated as:

$$Displacement = Velocity_{max} \times Time$$

Here, max velocity = 65 km/h = 18.05 m/s & time = 0.15 seconds.

$$\therefore Displacement = 18.05 \times 0.15 = 2.7075 \text{ m}$$

Hence, total frontal impact force can be calculated as:

$$F_{impact} = \left(\frac{1}{2} \times 500 \times 18.05^2\right) \times \frac{1}{2.7075} = 30083 \text{ N}$$

4.2 Side Impact

Assume that a vehicle travelling at 65 km/h collides with the considered stationary vehicle from the side. Time of collision for side impact is considered to be 2 seconds.

$$Displacement = 18.05 \times 0.2 = 3.61 \text{ m}$$

Using the Work-Energy Theorem,

$$F_{impact} = \left(\frac{1}{2}mv^2_{initial}\right) \times \frac{1}{D}$$

$$F_{impact} = \left(\frac{1}{2} \times 500 \times 18.05^2\right) \times \frac{1}{3.61} = 22562.5 \text{ N}$$

4.3 Rollover Impact

For rollover impact, the ATV is considered to be dropped on its roof on the ground from a height of 10 feet (3 m). Since road and ground are non-deformable bodies, impact time is taken as 1.5 seconds.

During the fall, the PE of the vehicle changes into KE:

$$m \times g \times h = \frac{1}{2} \times m \times v^2$$

$$\therefore v = \sqrt{2 \times g \times h}$$

$$v = \sqrt{2 \times 9.81 \times 3} = 7.67 \text{ m/s}$$

As seen in previous calculations,

$$W_{net} = \left| -\frac{1}{2}mv^2_{initial} \right|$$

$$\therefore W_{net} = \left| -\frac{1}{2} \times 500 \times 7.67^2 \right| = 14707.225 \text{ N}$$

$$\text{But, } W_{net} = F_{impact} \times D$$

$$\therefore F_{impact} = 14707.225 \times \frac{1}{D}$$

Where, $Displacement = Velocity_{max} \times Time$

$$\therefore D = 7.67 \times 0.15 = 1.1505 \text{ m}$$

$$\therefore F_{impact} = 12783.33 \text{ N}$$

5. FINITE ELEMENT ANALYSIS (FEA)

Finite Element Analysis (FEA) is a tool used to simulate the results of any given physical phenomenon and is used for solving problems of engineering and mathematical models. FEA has been used to perform structural analysis on the CAD of the chassis to simulate its deformation and determine the maximum force position and the Factor of Safety (FOS) in each of the impact cases. The drawing file created using SOLIDWORKS software is imported into ANSYS for the purpose of analysis. The CAD is basically divided into a mesh of numerous small parts to demonstrate the effect of force on a minute scale. This process is called as Meshing. The element size used in meshing is 0.015m.

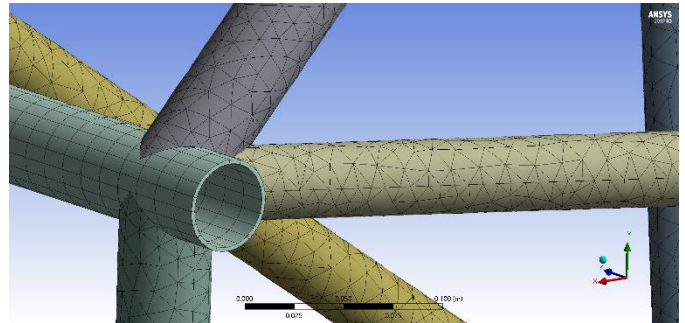

Fig -5: Meshing of Chassis

5.1 Front Impact Analysis Results

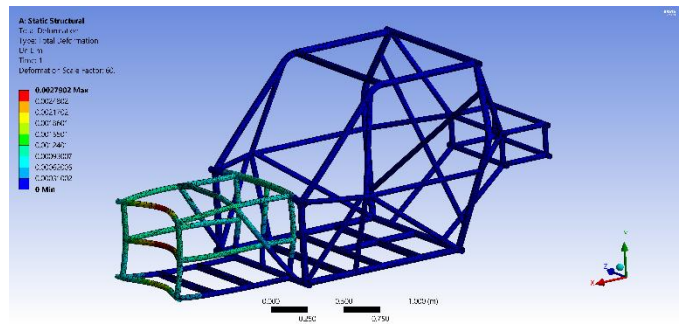

Fig -6: Front Impact Analysis

Force Applied: 30083 N
 Stress Induced: 198 MPa
 FOS = 2.83
 Deformation Scale Factor: 60
 Deformation: 2.48 mm

5.2 Side Impact Analysis

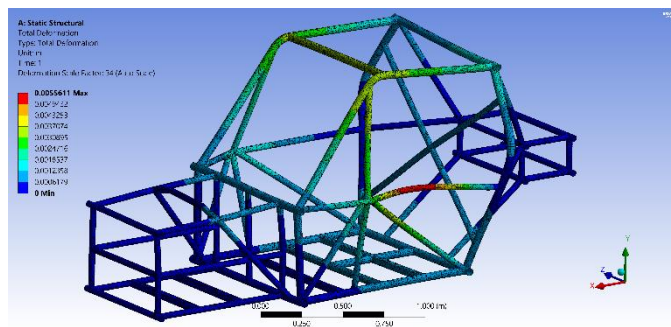

Fig -7: Side Impact Analysis

Force Applied: 22563 N
 Stress Induced: 150 MPa
 FOS = 3.73
 Deformation Scale Factor: 34
 Deformation: 4.94 mm

5.3 Rollover Impact Analysis

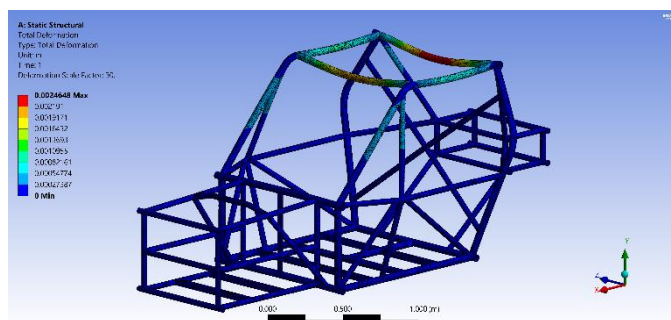

Fig -8: Rollover Impact Analysis

Force Applied: 12784 N
 Stress Induced: 240 MPa
 FOS = 2.33
 Deformation Scale Factor: 30
 Deformation: 2.46 mm

6. CONCLUSION AND FUTURE SCOPE

The results of the structural analysis reveal that the stresses acting in each of the impact conditions are much less than the Tensile Yield Strength of the material of the chassis. Hence, the design of the chassis can be considered to be safe in the toughest of impact conditions. We can conclude that all the steps in designing have been fulfilled and all the objectives have been achieved.

The segment of dual seater ATVs is rising in scale day-by-day and engineering motorsport competitions are encouraging participation in this class of ATV racing. Ultimately, this will provide students and professionals with a hands-on experience of vehicle designing and get them acquainted with advanced manufacturing processes. Innovative solutions to the constraints of All Terrain

Vehicles currently sold in the market will be possible through brainstorming by a larger number of individuals.

7. REFERENCES

- [1] Abhinav Sharma, Jujhar Singh & Ashwani Kumar, "Optimum Design & Material Selection of a BAJA Vehicle", International Journal of Current Engineering & Technology, 2015, Vol. 5, Issue 3.
- [2] Anthony Taylor Owens, Marc Daniel Jarmulowicz & Peter Jones, "Structural Considerations of a Baja SAE Frame", Motorsports Engineering Conference & Exhibition at Dearborn, Michigan, December 2006, SAE Technical Paper Series.
- [3] AISI 4130 Properties: www.matweb.com
<http://www.matweb.com/search/datasheet.aspx?MatGUID=a2fe6ff24cf44bf1bdebf35b1b2b6259>
- [4] AISI 1018 Properties: www.azom.com
<https://www.azom.com/article.aspx?ArticleID=6115>
- [5] B. K. Sati, Prashi Upreti, Anirudh Tripathi & Shankar Batra, "Static & Dynamic Analysis of the Roll Cage for an All-Terrain Vehicle", Imperial Journal of Interdisciplinary Research, 2016, Vol. 2, Issue 6.

8. BIOGRAPHIES



The author, **Ritvij Shah** is a final year student of Mechanical Engineering at Dr. V. K. MIT World Peace University, Pune. He is a part of the collegiate team participating in the off-road motorsport competitions RCDC India and BAJA 800.