

Visual Assistance for Blind using Image Processing

S.Mahalakshmi¹, Veena N², Anisha Kumari³

^{1,2}Assistant Professor, Dept. of ISE, BMSIT&M, Karnataka

³UG Student, Dept. of ISE, BMSIT&M, Karnataka

Abstract - Visually impaired people or in other words especially abled people are the ones who face a lot of difficulties even to accomplish their daily routine chores. Most of them even though they don't want, have to rely on other people for some kind of help. There are thousands of technologies being developed or have been developed for the assistance of these people. Computer vision being one of these technologies is providing the most promising solution while being the affordable and accessible at the same time. The aim of this seminar paper that we have chosen is based on the implementation of a wearable visual aid for visually impaired people in which speech commands are accepted from the user. This system will continuously record video of the surrounding and will convert it into frames. After analyzing these frames the system will alert the person about some obstacle or the surrounding. The main advantages are the portable, affordable and accessible system using image processing technologies is able to help visually impaired people. However, for the future scope of work we can minimize the use of hardware devices being used with a decrease in the size of the system design. This will make them able to do their day to day activities themselves without being dependent on anyone and also to guide them through their way.

Key Words: Wearable aid, computer vision, image processing, visual assistance, Blind

1. INTRODUCTION

Visual impairment is one of the issues that several millions of people suffer from. They go through a lot of difficulties even to complete the basic chores. Even in their own home or office the struggle to navigate from one place to another without being dependent on anybody. As per the data from WHO(world health organization) there are around 250+ million people with visual disablement out of which nearly 35+ million are totally blind which constitute a huge part of the population. Even though there are traditional ways to help these people such as a cane to help them navigate or a guide dog, they are not sufficient or error prone. They do not help them visualize the object which is in the nearby surrounding even though they can help them to avoid any obstacles in their way. The need today is to provide a solution which will not only help these especially abled people to avoid obstacles and deal with their daily chores but to help them visualize the world around them. This will help them in

living a better life. The main objective is to develop a wearable device using computer vision technology for blind people who will help them in avoiding obstacles and visualizing the world around them. This system will provide assistance to the blind people by taking speech commands to detect object using image processing technique and will provide audio output to the person to track their way around the obstacles. This system will also recognize some major sign boards such as sign for "Washroom" and would inform the blind person as soon as the sign is recognized. Main Objective of the system is identification of objects and sign boards. This will help the visually impaired person to manage day-to-day activities. Thus, the proposed system will help the visually disabled people to navigate their way through any obstacle and will give them a sense of visualization of world around them.

2. EXISTING SYSTEM

There are lots of strategies or ways that have been adopted by visually impaired people to address this hassle of theirs.

A traditional approach that has been used for years by the visually impaired humans is using dogs that could help so as to navigate through their paths or using walking canes to keep themselves away from any obstacles. Both of them are inexpensive or reachable but aren't error prone. Being error prone is what is wanted for blind people as even the slightest of blunders can motive a large damage.

Another manner to cope with this problem is to provide blind people with clever rehabilitative shoes alongside the spectacles. Each such shoe is surmounted with ultrasonic transducers to detect objects at unique level of heights and spectacles have a pair of ultrasonic transducers mounted centrally stored above the bridge and with a buzzer at one of the ends. A major drawback of this sensor primarily based approach is that it is just beneficial to detect items in place of recognizing them and hence image processing gives a promising answer to address such situations.

One more traditional solution used was actual time visual recognition in which ends are transformed to a 3-D Audio. This kind of system uses a consumer server method in which

video is captured with a camera tool which includes “GoPro” on the client side, and is streamed to the server for actual-time picture popularity with existing object detection models. The main disadvantage of the usage of this kind of device is the latency that it reasons which makes it wrong for real time applications.

The most promising answer that this survey has landed us to is, “haar Cascade based object identity” that’s the most appreciably used technique for object identity and popularity. This classifies the whole image into negative and positive categories by the use of a supervised approach.

The current solutions suffers from downsides along with use of plenty of sensors, now not applicable on actual time application, not being portable. The objective now is to attempt to cope with as many drawbacks as we can in the proposed machine.

3. PROPOSED SYSTEM

The proposed system will help the blind people by taking in the speech commands to detect object and it’s position using image processing technique and will provide audio output signals to the person to track their way around the obstacles. This system will also work for some major sign boards such as sign for “Washroom” and would inform the blind person as soon as the sign is recognized. Main Objective of the system is identification of objects and sign boards. This will help the visually impaired person to manage the everyday activities.

This system will help the visually impaired people to navigate their way through any obstacle and will give them a sense of visualization of world around them.

4. ARCHITECTURE/DESIGN

The machine acts by means of supplying speech instructions to the user through interface. A microphone captures the speech as input. The acquired input is diagnosed with the aid of the use of Google API. Also, it makes use of image processing as its primary approach to identify objects and signal boards. The video is captured by the Pi camera that is attached to the CSI port, which is then transformed into data frames for further processing. These frames are preprocessed for higher results. Now, Image processing algorithms for the item detection is carried out on these statistics frames and the object is identified. Audio commands from headsets are given to the user to inform him/her approximately the current position of the item.

Obstacle detection is done using ultrasonic sensors that are attached to the system. Any obstacle encountered inside the course is notified to the blind man or woman through generating a beep sound from the buzzer.

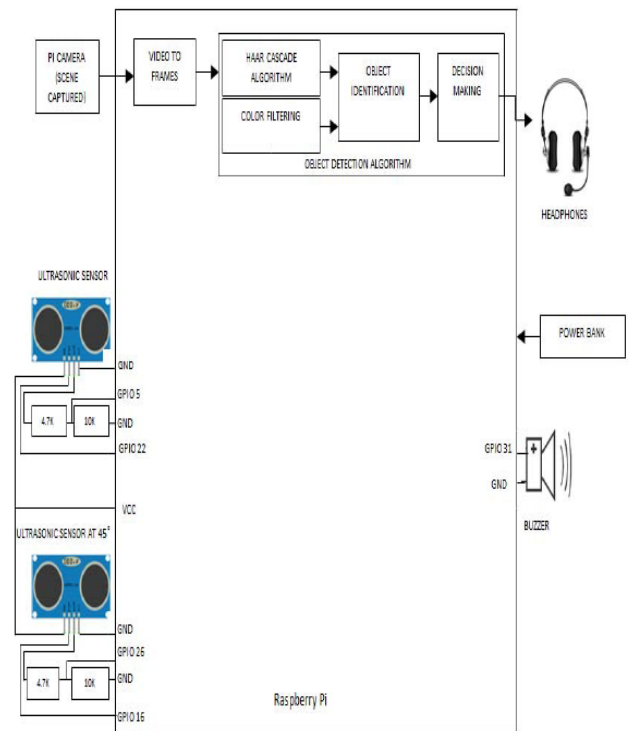

Fig -1: System Architecture

5. IMPLEMENTATION

The first step that occurs in this machine is that the digicam captures the video which is then divided into frames. Object detection is finished on those frames the use of “Haar Cascade classifier” and primarily based object detection technique.

The Open CV library in Python has capabilities mainly to detect items. It delivers software program packages that are used to teach classifiers for their item detection, referred to as Haar Training.

Object Detection the use of Haar characteristic based cascade classifiers is a machine learning based approach where a cascade function is skilled from a massive number of fine and negative pictures. It is then used to detect features of the object in distinctive images. The algorithm extracts snapshots using a whole lot of positive and negative images. A Haar-like characteristic can be taken into consideration as a template of numerous white and black rectangles interconnected. The features used are specific length and square in shape.

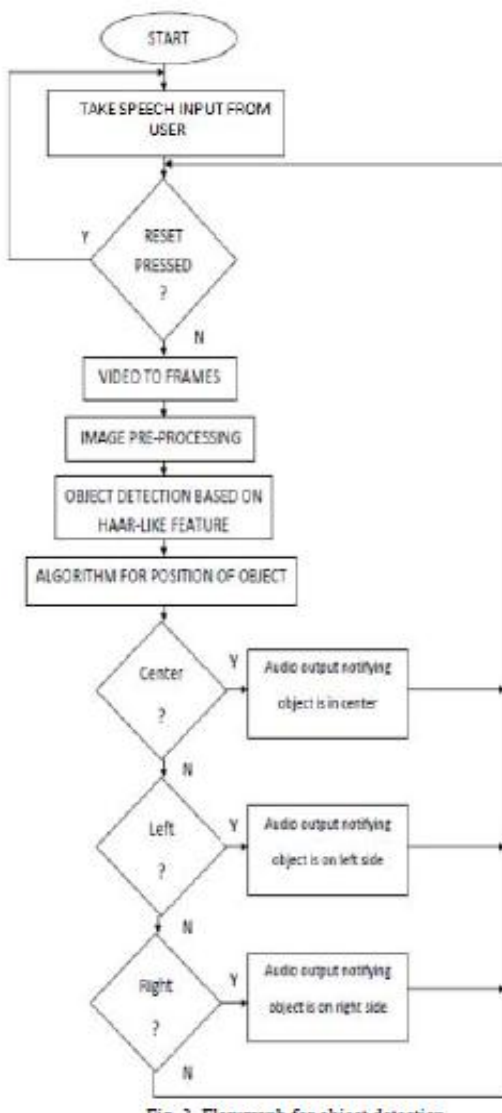

Fig -2: Process Chart

Various components of this system are:

- Raspberry Pi
- Pi Camera
- Ultrasonic sensor
- Open CV and Python

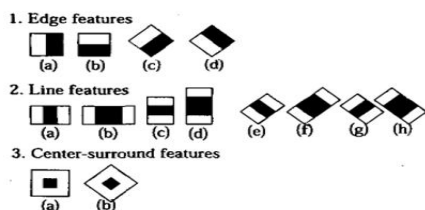

Fig -3: Feature prototypes of simple Haar-like and centre surround

The features price for the given masks is calculated because the weighted sum of depth of the pixel intensities included via the whole masks. But all the functions extracted will no longer be beneficial for the reason at hand. At first, images with object of interest (tremendous picture) and images void of object of concern (negative image) are captured. Images are resized and transformed to grey scale the usage of this formula:

$$Gray = 0.2989R + 0.5870G + 0.1140B$$

Where, R, G and B are the Red, Green and Blue additives in a pixel of an image. Text documents of positive and negative photos are generated which incorporates the coordinates of the positive and negative training samples along with their names in a distinct order. Text documents so created are used to achieve a vector record. This report carries compact records of positive instances of items and negative photo inclusive of background. The training of classifiers is done the usage of the vector report. After the training is completed, the output is stored in a listing in the form of text files. Finally, those documents are converted into a single xml document which is the very last classifier. The equal classifier is used in python code to detect in addition to tune the item. Commands like 'left', 'right' and 'center' given via headsets to resource the blind man to reach the item.

In color primarily based item detection some colored objects like a green bottle; a purple ball is detected and tracked the usage of color based object detection technique. At first, the upper and lower limitations of shade of the object are defined in HSV color. Video is captured and transformed to frames. These frames are transformed into HSV color format. The picture received will be a binary picture and it's eroded and dilated to take away noise. Then the largest contour in this binary image is determined and then the coordinates and radius of a circle enclosing this contour is acquired.

All the selection taken through the system is primarily based on the input voice command from the user. If the voice command is to identify a selected signal then that feature might be invoked.

6. RESULTS

The proposed system is useful for visually disabled people. It not only helps them avoid any obstacle but also helps them in visualizing their nearby environment.

