

Designing an Interleaved Boost Converter Driving A BLDC Motor with Different Controller for EV Application

Saheema M.R¹, Dr. Ananthapadmanabha B.R²

¹M. Tech Student, Department of Electrical and Electronics Engineering, National Institute of Engineering, Mysuru, India.

²Associate Professor, Department of Electrical and Electronics Engineering, National Institute of Engineering, Mysuru, India.

Abstract -Environment pollution and exhaustion of natural resources are the main reasons for global environment hazard and there are very less approaches to reduce this problem especially air pollution caused by vehicles as these are dependent on fossil fuels for working and leads to toxic gases emission. As a developing country like India where the population is a main issue and usage of two-wheeler is increasing and leads to air pollution and people are facing health issues mainly lung cancer or breathing problem. Many researchers are going through various research to make changes in automobile technology so that the energy crisis issue can be reduced to a much greater extend. This paper is mainly focused a designing an Interleaved Boost converter driving a BLDC motor for the electrical vehicle application and analyzing the performance result with PID and Fuzzy controller.

Key Words: IBC (Interleaved Boost converter), PID controller, fuzzy controller, BLDC motor, Electrical Vehicles.

1. INTRODUCTION

We are in an era where we are facing an energy crisis mainly due to non-renewable sources of energy, mankind has made development so much that he is completely depended on non-renewable energy and we are badly facing this crisis because of limited emission control strategies. It has become important to work on the factors that mainly help in reducing the crisis and to make life easy, pollution-free.

Among this one factor is reducing that reducing the pollution produced from vehicles especially two-wheeler, one which people depend more on an urban city which is run using petroleum/ diesel which produced toxic gases out. In many studies it shown using electric vehicles we can reduces this problem to a greater extend and so there are electric cars, but as mentioned before two-wheeler play a very important role. In this paper, an interleaved Boost converter powering the BLDC motor is designed and simulated, and using different controllers the speed is analyzed.

1.1 BLDC Motor

An electronically commuted DC motor nothing but a BLDC does not have brushes. The controller provides pulses of current to the motor windings which control the speed and torque of the synchronous motor or A BLDC is powered by direct-current electricity via an inverter or switching power supply which produces an alternating current electric current to drive each phase of the motor via a closed-loop controller. The controller provides pulses of current to the motor windings that control the speed and torque of the motor. This motor is highly efficient in producing a large amount of torque over a vast speed range. In brushless motors, permanent magnets rotate around a fixed armature and overcome the problem of connecting current to the armature. Commutation with electronics has a large scope of capabilities and flexibility. They are known for smooth operation and holding torque when stationary. The BLDC motor uses the internal rotor position feedback for commutation to determine the switching sequence of the phases of the stator winding. Feedback normally requires additional rotary encoders or Hall sensors, the trapezoidal-shaped back EMF BLDC motor is designed to develop trapezoidal back EMF waveforms. Controlling of BLDC motor using Hall sensors is comparatively easier to operate and understand than a sensor-less method of controlling the BLDC motor.

1.2 Interleaved Boost Converter

The method of paralleling converter is called interleaving to increase the efficiency and reliability of power electronic systems which are mainly used in Electric vehicles, UPS, etc. , Using Interleaved Boost Converter, the system voltage can be stepped up, and lower current and voltage ripples can be achieved at the output of the converter and using interleaved boost converter one reduces the size of the storage devices such as inductors and

capacitors. The interleaved boost converter having coupled inductors ensures reduced current ripples.

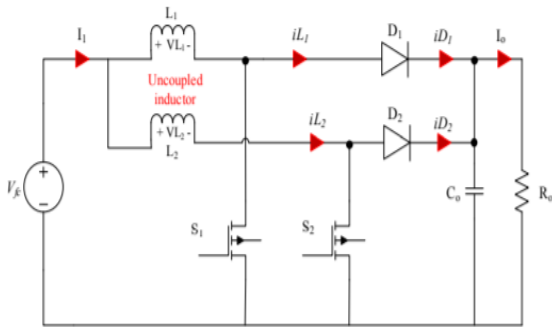

Fig -1: Circuit diagram of an uncoupled inductor of an interleaved boost converter

1.3 Interleaved Boost Converter design specification

Table -1: Parameters and ratings

| | Typ | Min. | Max. | Units |
|--------------------------|----------|-------|-------|-------|
| Vin | 24 | 23 | 25 | V |
| Pout | 250 | 250 | 250 | W |
| Vo | 48 | 48 | 48 | V |
| Io | 5.21 | 5.21 | 5.21 | A |
| Eff. | 0.9 | - | - | %d |
| D | 1 | 1.000 | 1.000 | %d |
| Fsw | 50000 | | | Hz |
| I _{In_1ph} | 5.79 | 6.04 | 5.56 | A |
| L (L1=L2=L) | 2.19E-04 | | | H |
| Creq | 2.44E-04 | | | F |
| C _{actual_min.} | 2.70E-04 | | | F |

1.4 Designed Closed Loop of BLDC Motor

The output of IBC is DC but we required AC input to the BLDC motor so a Universal gate and the output of the converter is fed to a universal gate through D3, It's because without diode D3 the controller output voltage goes higher at some point of time and the converter performance is disturbed.

Here in this work, a sensor-based control of BLDC motor. i.e., Hall Effect sensors are used to sense the position of the rotor and send an appropriate signal to the gate of the universal converter to control the motor speed. Here no reference speed is considered that's because to know what is the speed of the motor at these designed values of the converter. The output of the universal gate is fed to the BLDC motor which has trapezoidal back EMF and output from the BLDC motor is fed to the Hall sensors module implemented using the truth table1, and the output of the Hall sensor module is fed to the switching pattern module based on back EMF, and this output which is fed as input to the gate of the universal bridge, controlling the converter performance and in-turn controlling the motor.

1.5 Simulation Circuits

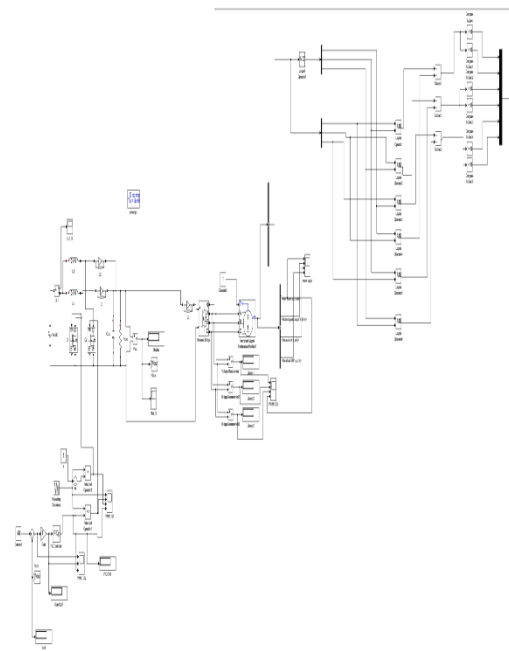

Fig -2: A Simulation output of Interleaved Boost converter integrated with BLDC motor having PID controller

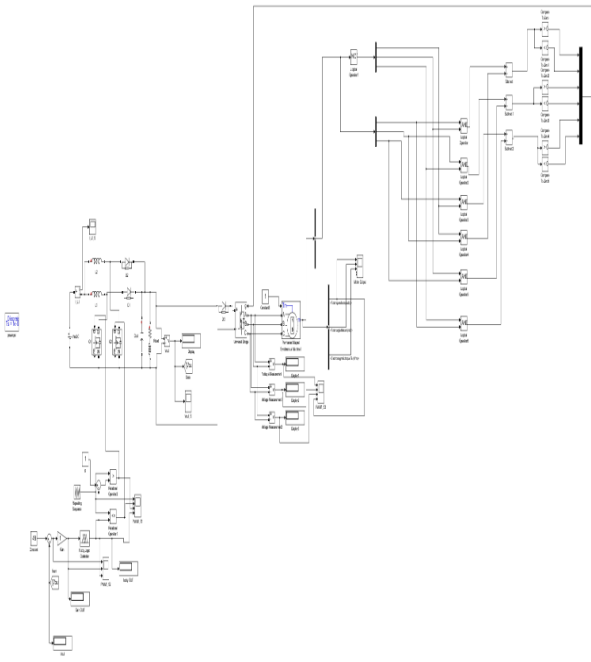

Fig -3: A Simulation model of Interleaved Boost converter integrated with BLDC motor having Fuzzy controller

1.6 Simulation Output

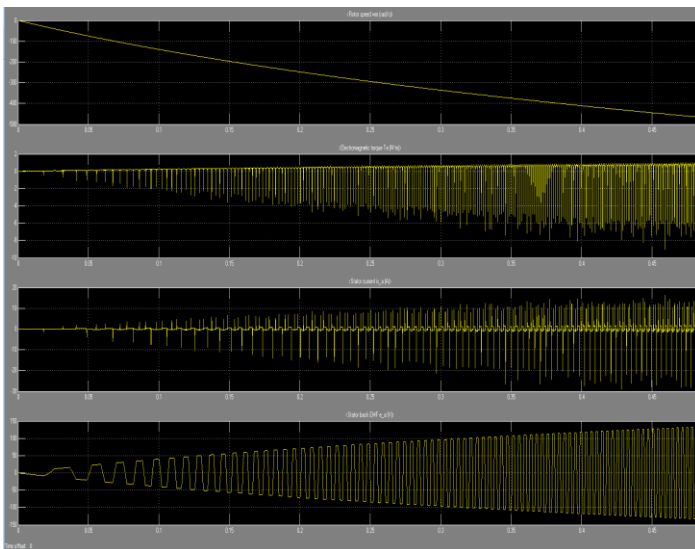

Fig -4: A Simulation output of Interleaved Boost converter integrated with BLDC motor having PID controller

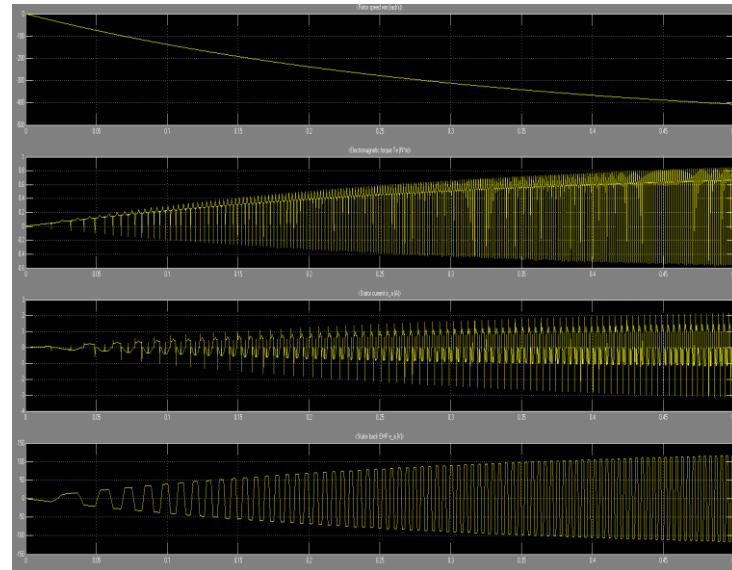

Fig -5: Simulation output of Interleaved Boost converter integrated with BLDC motor having Fuzzy controller

From the results obtained,

we observed that IBC with PID controller integrated with BLDC motor for 0.5 sec, the torque obtained is 0.25 Nm and rotor speed is 472 Wm/rad resulting in the power of 119W and we observed that IBC with Fuzzy controller integrated with BLDC motor for 0.5 sec, the torque obtained is 0.7 Nm and rotor speed is 406Wm/rad resulting in the power of 284 W.

2. CONCLUSIONS

From the simulation result, Interleaved Boost Converter with controller gives the desired output voltage 48V for which the converter is designed. In this project carried out replacing the PID controller with a fuzzy controller, we observe that using fuzzy controller the circuit complexity was reduced by removing PID components, and the output power obtained is 284 W higher than that of power obtained from the PID controller is 119 W obtained at a duration of 0.5 sec and also with fewer distortions.

Therefore, Interleaved Boost Converter integrated with BLDC motor with a fuzzy logic controller is a more suitable choice for electric vehicle applications and we can say that Interleaved DC-DC Boost Converter is a suitable for Electric Vehicle application having a mass of 110kg, acceleration of 0.864 m/s², with a speed of 7.78 m/s and delivering a power of 244W.

REFERENCES

- [1] "Interleaved DC-DC Converter Fed BLDC Motor Drive for Electric Vehicle Application" Journal of Network Communications and Emerging Technologies (JNCET) Volume 6, Issue 8, August (2016).
- [2] Alen Silven and J. T. Kuncheri "Performance Improvement of a BLDC Motor using Interleaved Buck Converter", International Journal of Engineering Research & Technology (IJERT), Vol. 4 Issue 09, September-2015
- [3] K.Praveen "Converter fed PMBLDCM Drive with Reduced Switches for Adjustable Speed Applications", International Journal of Engineering Research & Technology (IJERT), Vol. 2 Issue 11, November - 2013
- [4] Gaurav A. Chandak and A. A. Bhole "An Electric Braking System Controller for Brushless Dc Motor in Electric Vehicle Application", International Journal of Electrical Engineering & Technology (IJEET) Volume 8, Issue 4, July-August 2017.