

# Prototype Design of A UGV for Military Purpose

Aakash Chothani<sup>1</sup>, Aniket Desai<sup>2</sup>, Himanshu Kale<sup>3</sup>, Prof. Pragya Gupta<sup>4</sup>

<sup>1</sup>Department of Electronics Engineering, KJ Somaiya College Of Engineering

<sup>2</sup>Department of Electronics Engineering, KJ Somaiya College Of Engineering

<sup>3</sup>Department of Electronics Engineering, KJ Somaiya College Of Engineering

<sup>4</sup>Department of Electronics Engineering, KJ Somaiya College Of Engineering

\*\*\*

**Abstract** - This project aims to design a low-cost Unmanned Ground Vehicle (UGV), a robotic vehicle that can be controlled remotely without any on-board human presence. The UGV is also able to move autonomously while automatically detecting and avoiding obstacles. A microcontroller has been used as the brain of the vehicle altogether which includes other components such as Ultrasonic and Infrared sensors, webcam, batteries, power bank, motor controller, and a PS Controller. Few practical applications of the UGV are autonomous wheelchairs for handicapped persons which allow them to move around independently and autonomously without any human support. There are various places where this idea can be easily used which includes untapped indoor commercial markets such as malls, hotels, banks, nursing homes, hospitals, offices, stores, schools, museums, etc.. The proposed idea aims at making a UGV specifically for military purposes and catering to the harmful environment and geological barriers.

**Key Words:** UGV, SolidWorks, GPS, RF, PS Controller.

## 1. INTRODUCTION

The basic functioning of a UGV is that it operates in contact with the ground and without any on-board or explicit human presence. The most advantageous application of UGVs is that it can be used in an environment where it may be inconvenient, dangerous, or impossible to have a human operator present. Usually, the UGV vehicle accommodates few sensors to observe and analyse the environment, and then it will either communicate with its human operator to pass on the existing information and take further decisions or automatically tune itself to react to the environment. If it has to choose to pass on the information to the human operator then all its teleoperation will be conducted under the human operator. These UGVs have successfully proved themselves to be the land-based counterpart to various unmanned aerial and ground vehicles. One of the main reasons for the development of these UGVs is to perform a variety of dull, dangerous, and luring activities for both civilians and the military people. Based on its application and significance UGVs include the following components:

1. Platform

2. Sensors

3. Guidance Interface

4. Communication link

5. System Integration Features

UGV for military purposes must have a robust chassis which can give better results in all-terrain. The main objective of our project is to carry the load consisting of first aids, necessary equipment required for soldiers. UGV includes some sensors which are used for navigation, another is environment detection. Sensors can include compasses, odometers, gyroscopes, cameras for triangulation, laser, and ultrasound range finders, and infrared technology. Unmanned ground vehicles are mostly Remote-Operated and Autonomous, although Supervisory Control is used to refer to situations in which a combination of decision-making by UGV systems and the remote human controller. UGV contains a tank to drive to tackle all types of terrains and to continuously assist the soldiers. UGV carries all types of loads or the extra ammo for soldiers and automatically follows them with the help of GPS communication. We can also use this kind of system for soldier tracking from base camp which is very useful in dangerous areas. UGV provides service in all terrains.

## 2. LITERATURE REVIEW

The paper titled "Four Different Modes to Control Unmanned Ground Vehicle for Military Purpose" [1] describes four different ways in which a UGV can be controlled. These modes are - command control mode, self-control mode, gesture control mode, and raptor control mode. A prototype is built using which these four modes are tested. Different algorithms are developed for the above-mentioned modes and depicted pictorially in the form of block diagrams and flowcharts. Two of the above mentioned modes i.e. command control and self-control mode are approached in this paper.

The thesis "Design and Construction of a GPS Based Unmanned Ground Vehicle (UGV)" [2] describes extensively the usage of GPS in UGVs. The author has also described the use of the "Kalman filter" algorithm to eliminate noisy and erroneous data. Detailed test results in the form of graphs are provided for a better understanding of the filtering algorithm. Pseudo-code

snippets provided help in understanding the navigation guidance algorithm and filtering algorithm.

UGVs often have GPS mounted on them for their position coordinates and movement. The paper titled "Real-Time Dynamic Relative Positioning of An Unmanned Ground Vehicle" [3] talks about how a relative positioning methodology can be adopted for high-speed navigation of a UGV where GPS data is weak or unreliable. This can help in increasing the scope of UGVs in areas like mine and interiors of a dense concrete building. Also, the paper talks about selecting the appropriate sensor from a wide range of available sensors for the specified application. A comparative study between encoder and accelerometer is done and it is concluded that encoders perform better in finding out the distance travelled.

For controlling UGVs from long distances various protocols are used. The paper "Development of a Wireless Surveillance Robot for Controlling from Long Distance" [4] highlights the use of the World Wide Web (www) for control of UGV from long distance. The robot has been developed for multipurpose applications related to surveillance and security. The base station must be connected to the internet using wired or wireless networks and the robot must be connected to the internet using wireless network i.e. Wi-Fi. Also, the effect of different internet speeds on the accuracy of image transmission is discussed. It is concluded that for optimum accuracy, 512 Mbps constant wireless internet is needed.

The paper "An Autonomous Robot Framework for Path Finding and Obstacle Evasion" [5] describes two methods for movement of robot i.e. "Line Follower" and "Obstacle Handling". RX TX optocouplers with LM324 IC are used for line follower and the sonar sensor is used for obstacle handling.

A UGV is generally designed to go at hard-to-reach places and hazardous spots. In "Design of a Smart Unmanned Ground Vehicle for Hazardous Environments" [7], the designed UGV is designed to manoeuvre in an "environment with rough terrains and narrow escape routes with minimum space for directional movements". The four-wheeled chain drive mechanism is used which enables the vehicle to move in rough terrains. Aluminium sections make the chassis lightweight. The small size and lightweight of the designed vehicle make it suitable for military applications like "de-mining operations, bomb disposal and combat tasks at enemy hideouts". The paper suggests the use of an invisible Infrared searchlight instead of an ordinary searchlight for navigation in dark.

### 3. PROTOTYPE DESIGN

Generally, all UGV's (Unmanned Ground Vehicles) have a proper architecture to incorporate the numbers of sensors to discover the environment. Different types of

applications required different types of UGV'S. In short, type of UGV depends on multiple applications. We have to consider several factors like the type of environment and application in the development of UGV. There can be a variation in the environment concerning terrain (rough to indoor smooth surface) and this may create a requirement for a certain level of agility or size etc. We can go with the 2 - layered stainless steel chassis (as shown in fig. 1). Stainless steel is quite heavyweight compared to aluminium and also cheaper than other military-grade materials. Also, stainless steel can provide the required rigidity to the UGV base. UGV for the military purpose must have robust chassis which can give better results in all-terrain due to this reason we can go with stainless steel as a raw material for chassis.

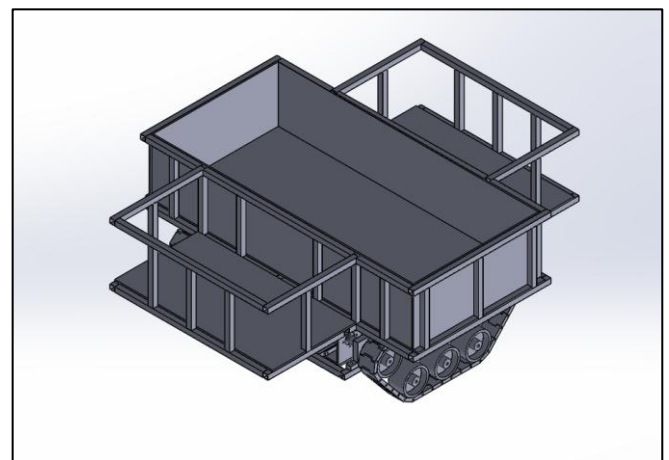
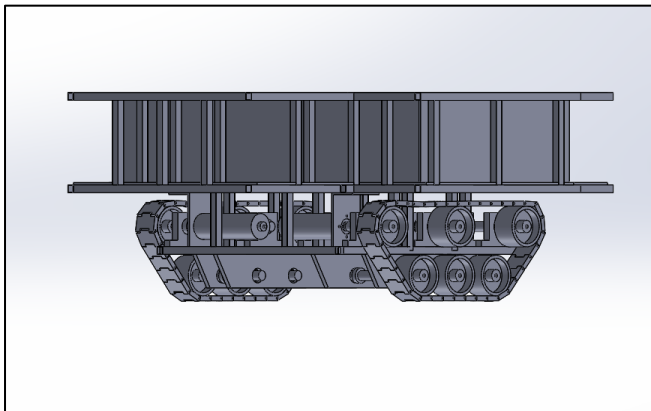

**Fig -1:** View of the designed UGV showing chassis.

The mechanical design must be robust to be able to hold out against a very harsh environment and be able to move in the off-road environment. Agility has also proved to be a very dominant design factor; we can implement a differential drive for that purpose. We can use a strong all-terrain two-layer mechanical frame for our UGV which features an off-terrain strong pulley and a decent suspension system. The main objective of our project is to carry the load consisting of first aids, necessary equipment required for soldiers, and for this we can make proper design and analysis of vehicles in SolidWorks. This design can be used further for manufacturing the vehicle. We can design our vehicle in such a way that it can carry the maximum load without getting toppled or stuck in front of the obstacle.

Now if we think from the drive point of view then we have two options that are differential drive with wheels or differential drive with continuous tracks. Both types of drives have some advantages and some disadvantages. First, consider Continuous tracks that are reliable and provide good mobility for rough terrain and low ground pressure. Traction is greater in continuous tracks compared to wheels but the best results are obtained

based on terrain. Power efficiency is another major advantage of using continuous track wheels. Continuous tracks have proved to have a very good performance and to further increase power delivery efficiency they feature an optimized traction system. Continuous tracks have many advantages like ground impact, weight growth potential, aesthetics, etc. Continuous tracks are suitable for all the applications where speed is not a primary concern. Whereas differential drive with wheels has a low production cost and also it is lightweight compared to continuous tracks. But continuous tracks are superior to wheels in the case of military applications. Because of these reasons we can think of differential drive with continuous tracks for this application. The selection of the best system mostly depends on a few important factors like traction, ground pressure, steering, and suspension.



**Fig -1:** View of the designed UGV showing motor and continuous tracks.

Here, we can think of DC geared motor, especially with a planetary gear head. Such addition of gear to the motor reduces speed and increases torque. Torque multiplication, speed reduction, and inertia matching - these are the advantages of using a gearbox with the motor. In this application, we don't need great speed, but we require large torque so UGV can carry the maximum amount of load in rough terrain. We can select a motor based on the rpm rating and torque calculation. Torque calculation depends on the weight of the UGV. The operating voltage of the motor can be 12v, 18v, or 24v. We can make different compartments for first aid, ammunition, and other necessary equipment for combat on the top side of the chassis. We can use lightweight material for making such compartments. We can place a battery box as well as electronic circuitry between the two layers of chassis so that it remains safe.

The UGV is designed to operate in two modes i.e. manual mode and patrol mode. In the manual mode, the UGV is controlled by a person from a remote base station. The person sends commands for movement of the UGV on the basis of a live video feedback received from the camera

present on the UGV. In the patrol mode, the UGV keeps moving between the two checkpoints.

The proposed design has a GPS sensor which sends the vehicle's coordinates to the base station. The RF transmitter sends the coordinates to the RF receiver present on the base station. The GPS coordinates of the vehicle coupled with live video feedback will enable the manual controller at the base station to control the vehicle remotely. In the patrol mode, the vehicle will move repeatedly between two fixed coordinates. These two coordinates will be set from the controller to the vehicle.

At the base station, a PS controller can be used to control the UGV remotely. The buttons and analogue joysticks can be assigned values that can be sent to the UGV via a RF medium. Each value will correspond to an action performed by UGV. For instance, the joysticks can be used to control the motion of the UGV. The buttons can be used various actions like setting a checkpoint or for switching between the modes.

A gyroscope will help the vehicle to maintain its orientation. The proximity sensors present around the vehicle will help to detect obstacles and avoid collisions.

#### 4. CONCLUSION

The proposed design of the prototype is scalable and components can be changed/ upgraded to suit the specific applications. The chassis can be made of military-grade metal which will be much more durable as compared to proposed stainless steel chassis. The stainless steel chassis was suggested in the design considering the cost and unavailability of military-grade metal. The size of the UGV can be increased as well for carrying more loads.

#### REFERENCES

- [1] Mithileysh Sathiyarayanan, Syed Azharuddin, Santosh Kumar. "Four different modes to control unmanned ground vehicle for military purpose". International Journal of Engineering Development and Research, Volume 2, Issue 3, 2014.
- [2] Halit Hülako, "M. Sc. Thesis – Design and Construction of A GPS Based Unmanned Ground Vehicle (UGV)". September 2014.
- [3] Devendra Kumar Yadav, Pragyan Mishra, Kishan Kumar Patel. "Real-Time Dynamic Relative Positioning Of An Unmanned Ground Vehicle". Proceedings of the 11th INDIACOM; INDIACOM-2017.
- [4] Shahjada Mahmudul Hasan, Syed Mamun R Rasid, Avijit Mallik, Md. Rokunuzzaman. "Development of a Wireless Surveillance Robot for Controlling from Long Distance". International Journal of Engineering Research and Management, Volume-05, Issue-09, September – 2014.

- [5] Imran Sarwar Bajwa, Natasha Nigar, M. J. Arshad. "An Autonomous Robot Framework for Path Finding and Obstacle Evasion". International Journal of Engineering Development and Research, Volume 1, Issue 1, November 2011.
- [6] Zain Murtaza, Noaman Mehmood, Mohsin Jamil, Yasar Ayaz. "Design and Implementation of Low-Cost Remote-Operated Unmanned Ground Vehicle (UGV)". 2014 International Conference on Robotics and Emerging Allied Technologies in Engineering (iCREATE) Islamabad, Pakistan, April 22-24, 2014.
- [7] Saurav Chakraborty, Subhadip Basu. "Design of a Smart Unmanned Ground Vehicle for Hazardous Environments".
- [8] [www.robotics.stackexchange.com](http://www.robotics.stackexchange.com)
- [9] [www.sciencedirect.com](http://www.sciencedirect.com)
- [10] [www.online-sciences.com](http://www.online-sciences.com)