

Comparative Performance Review of IEEE 802.11ac and IEEE 802.11ax

Shivam Kalhans¹, Dr. Rajashekara Murthy S²

¹Student, Dept. of Information Science and Engineering, R.V. College of Engineering, Karnataka, India

²Associate Professor, Dept. of Information Science and Engineering, R.V. College of Engineering, Karnataka, India

Abstract - The sixth generation of wireless protocol IEEE 802.11ax has been launched and offers better performance than the previous fifth-generation wireless protocol IEEE 802.11ac. This paper reviews the performance of both wireless protocols in the same operating frequency of 5 GHz. We used Network Simulator NS-3 as a simulation tool that offers flexibility, lesser time to set up and ease the experiment to any scenarios we need to perform. Furthermore, this paper focuses on analyzing and comparing the throughput of protocol IEEE 802.11ax Mcs-11 and 802.11ac Mcs-9 with a certain payload size and a various number of clients. The other parameters are set at certain values, such as a spatial stream, channel width, modulation and coding scheme, guard interval time and simulation time. The simulation result shows that the IEEE protocol 802.11ax Mcs-11 has better throughput performance than IEEE 802.11ac Mcs-9 with a large number of clients. In the simulation, a node of access point was accessed of 512 clients, IEEE 802.11ax Mcs-11 have more long delay response time than IEEE 802.11ac Mcs-9 at the beginning for a few milliseconds, but after 0.5 ms IEEE 802.11ax shown a stable and bigger throughput value than IEEE 802.11ac that its shown decrease.

Key Words: IEEE, protocol, 802.11ax, 802.11ac, performance, throughput

1. INTRODUCTION

Wireless technology provides wireless communication services and supports mobility for many people around the world. Year by year wireless technology based on wireless protocol IEEE 802.11 has been developed and the trend is shown in figure 1. Wireless-LAN has been significantly developed and can be easily deployed at various zones, for example, airports, hotels, offices, malls, and home residences. One of the major improvements is in the number of users served by an AP (Access Point) system [12]. W-LAN described at IEEE 802.11 protocol implements a CSMA / CA (carrier sense multiple access with collision avoidance) techniques, requiring endpoints to listen for an all-clear signal before transmitting. In the occasions of interference, congestion or collision, the endpoint goes into a backoff procedure, wait for the channel all clear then transmits.

First of all, in CSMA the wireless remote station (RSTA) senses the channel and tries to avoid a collision by transmitting just when the channel condition is idle [3].

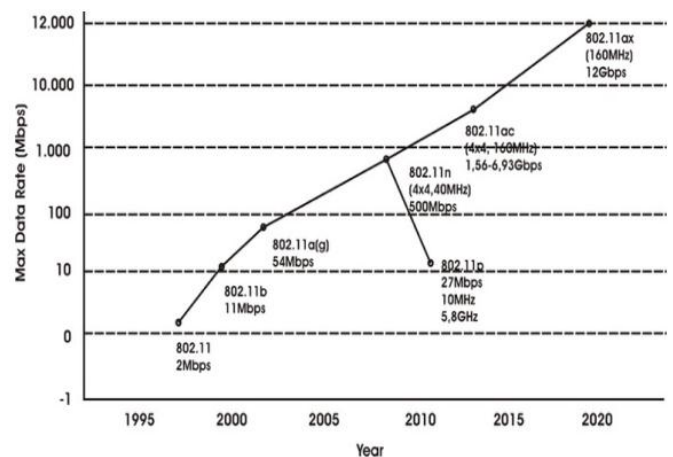

Fig. 1. Wireless technology trend [5]

When the RSTA senses another RSTA using the channel, then the RSTA waits for a random amount of times so the RSTA stops its transmitting before it returns to check whether the channel is free or not. When the RSTA can transmit, it transmits all packet data. RSTA sends an RTS / CTS (Request to send / clear to send) command to get access to shared media. The AP (Access Point) issues CTS commands to an RSTA at a time, and then the STA sends the entire frame to the AP. The RSTA waits for an acknowledgment (ACK), it commands from the AP that indicates the packet was received. If the RSTA does not get an ACK in time, it assumes that the packet collides with some transmitted packages, which directs the RSTA to an exponential binary back-off period. The RSTA will try to access the media and resend the packet after the countdown has expired [10]. Although the Clear Channel Assessment and Collision Avoidance protocols function work well to divide channels evenly among all RSTAs, the collision domain, and its efficiency decrease when the number of stations grows larger.

The Clear Channel Assessment Protocol scenario is shown in figure 2.

2. IEEE 802.11ac

The limited performance of the 802.11n protocol is the basis for the development of the 802.11ac protocol [1]. To get a higher performance in 802.11ac done in the following ways:

Greater bandwidth, namely 80 MHz and 160 MHz, as a development of 40 MHz bandwidth in the 802.11n protocol

Signal modulation is greater, using QAM-256 modulation, as the development of QAM-64 modulation used by the 802.11n protocol.

Implement multiple input multiple outputs with 8 spatial streams, which are larger than 802.11n, which only has 4 spatial streams.

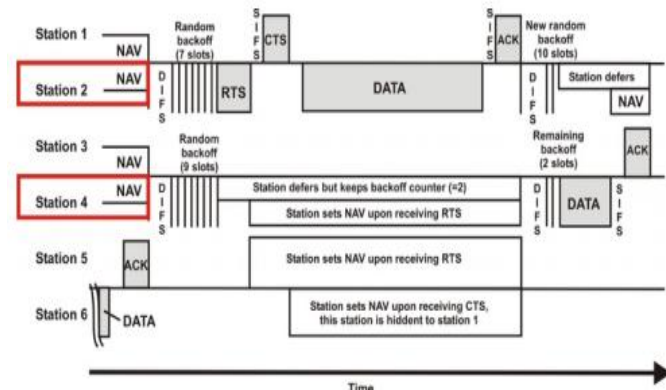

Fig. 2. Wireless 802.11 Clear Channel Assessment Protocol [3]

The 802.11ac Access Points (AP) that work in a frequency band 80 MHz and or 160 MHz still support 802.11n user protocols that are connected and can be served its communication well [9]. The way it works is that the beacon signal will be sent at a bandwidth of 20 MHz of 802.11n, which will be the main channel in the 80 MHz bandwidth. In this condition, the Access Point and the client connected to it will receive and process the data received on this main channel. So that clients on the 802.11n Access Point will be compatible and still be able to communicate data transmission on the 802.11ac access point (AP).

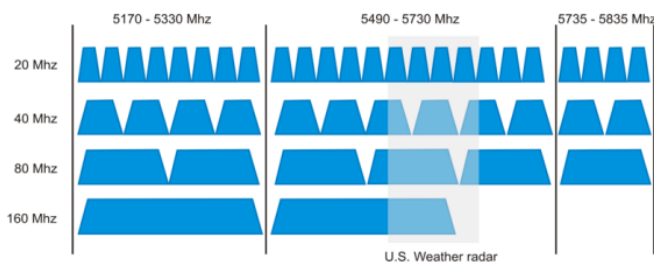

Fig. 3. Wireless 802.11ax channel allocation [2]

Various types of Access Points and its connected users have different carrier sensing periods and can transmit data at any time using various sub-channels. In theory, 802.11ac with 160 MHz bandwidth will be able to produce a throughput of 1.3 Gb/s [5].

3. IEEE 802.11ax

IEEE 802.11ax is a development protocol to improve the performance of the 802.11ac protocol, which has limited uplink contention-based access [2]. 802.11ax provides greater network capacity, higher efficiency, better

performance, and reduced latency. This new protocol is primarily aimed at implementing new methods to serve more users with reliable and consistent data flows that aim to increase throughput.

The features of IEEE 802.11ax over IEEE 802.11ac are shown in figure 4.

IEEE 802.11ax made significant changes to the standard physical layer [3]. However, 802.11ax still maintains compatibility with devices with the 802.11a / b / g / n / ac protocol, so that the 802.11ax RSTA can receive and send data to STA with the previous protocol. This legacy client will also be able to demodulate and decode 802.11ax packet headers, even if not the entire 802.11ax packet, and then back when the 802.11ax RSTA transmits. The difference in PHY characteristics between IEEE 802.11ax and IEEE 802.11ac is shown in table 1.

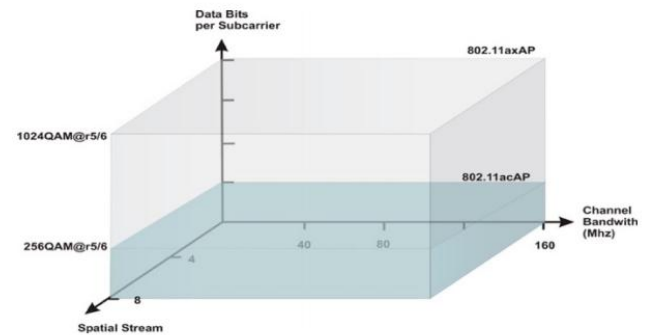

Fig. 4. Features of IEEE 802.11ax over 802.11ac [1]

Table I. PHY characteristic of IEEE 802.11ax and 802.11ac [3]

Wireless Protocols	Wifi 802.11ac	Wifi 802.11ax
Bands (GHz)	5	2.4 and 5
Channel Width (MHz)	20, 40, 80, and 160	20, 40, 80, and 160
FFT sizes	64, 128, 256, and 512	256, 512, 1024, and 2048
Subcarrier Spacing (kHz)	312.5	78.125
OFDM symbol interval	3.2 + 0.8 / 0.4	12.8 + 0.8 / 1.6 / 3.2
Highest Modulation	256-QAM	1024-QAM
Data rates	433 Mbps (80 MHz, 1 SS), 6,933 Mbps (160 MHz, 8SS)	600.4 Mbps (80 MHz, 1 SS), and 9,607.8 Mbps (160 MHz, 2SS)

The 802.11ax standard has two modes of operation [3] i.e. single-user and multi-user. In single-user mode, wireless sequential RSTA mode sends and receives data at once after they secure access to media. While in multiuser mode, can carry out simultaneous operations of several non-AP STAs.

The standard divides this mode further into Down-link and Up-link Multi-user [11]. Multi-user downlink is based on data carried out by the AP for several related wireless STAs simultaneously.

Multilink MU-MIMO provides features to both 802.11ac and 802.11ax access points so that they can receive and send simultaneously to multiple users (MU) from an access point. This feature provides flexibility for access points to serve user clients in the work area of the access point. The methods used in both protocols are multi-user MIMO and Orthogonal Frequency Division Multiple Access (OFDMA) [13].

The technology used on 4G cellular is implemented on IEEE 802.11ax to accommodate more users on the same channel, this technology is called OFDMA. The other method applied is to set specific sub-operators for one user. 802.11ax divides channels into the smallest sub-channels, with a total of 26 sub-carriers. The rules for channel allocation are by setting all available resources at the downlink, then all channels allocated for only a user at the same time. Figure 5 shows services to several users simultaneously.

4. METHODOLOGY

The performance evaluation of the 802.11ax and 802.11ac are counted from the receiving traffic through the wireless connection of AP node and Client node. A metric to compare performance between 802.11ax and 802.11ac is throughput, it describes the traffic size through a link in a selected range of time.

$$Throughput = \frac{\sum \text{number of packet}}{\sum \text{simulation time}} * 8/10^6 \text{ (Mb/s)}$$

(1)

802.11ac was simulated using QAM-256 modulations, while 802.11ax uses QAM-1024 modulation. Spatial streams cannot be used. The other parameters setting i.e. payload size, channel width, guard time intervals, and a number of clients, are the same for both.

In this simulation, we analyze and compare the IEEE 802.11ax throughput and the IEEE 802.11ac protocol by providing specific content and varying the number of clients. Table 2. shows the parameter setting.

Table -2: Simulation Parameter Setting

Parameters	802.11ac	802.11ax
Modulation and Codung	QAM-256	QAM-1024
Guard Interval	800 ns	800 ns
Channel Width	160 MHz	160 MHz
Frequency	5 GHz	5 GHz
Spatial Stream	1	1
Payload Size	1448 byte	1448 byte
Client number	2 to 512 clients	2 to 512 clients
Simulation time	2 s	2 s

Figure 6 shows the topology of the network in the simulation. Star topology is used in this simulation test because clients commonly use it. All clients are connected directly to the Access Point. Therefore, the Access Point's load is equal to the number of connected clients. By using this star topology, the

Access Point is forced to work optimally when they are serving client nodes. Therefore the performance of each Access Point (802.11ax and IEEE 802.11ac) could be monitored easily.

Scenario 1 shown the activities of the IEEE 802.11ax simulation. Each of the parameters setting is simulated which parameters i.e. Spatial Streams, Modulation and Coding Scheme set at a certain value. We simulate a number of clients from 2 up to 512 client numbers to find the optimal value of the data rates.

Simulation of the first and two of the scenarios were run with a number of clients from 2 to 512 clients. The process of the simulation was done to find the maximum value of the throughput of each protocol. Parameter settings of the protocols are summarized in table 2.

Scenario 2 shown the activities of the IEEE 802.11ac simulation. Each of the parameters setting is simulated to parameter setting table, i.e., Spatial Streams, Modulation and Coding Scheme set at a certain value. We simulate with a number of clients from 2 to 512 client numbers to find the optimal value of the data rates.

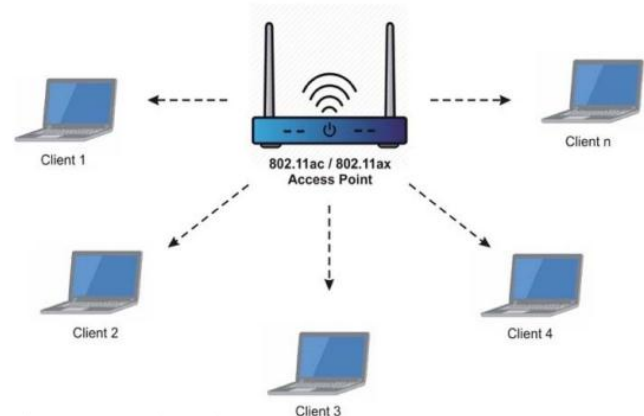

Fig. 6. Network topology

5. RESULT AND DISCUSSION

The simulation scenario 1 and scenario 2 considered several parameters set at a certain value. We run the simulation using various client number i.e.: 2, 4, 8, 16, 32, 64, 128, 256, 512 clients. The simulation time runs 2 seconds every data rate.

The simulation results of small client number i.e. 2 and 4 clients, show fast response time with good throughput value, while the bit rate value of IEEE 802.11ax bigger than IEEE 802.11ac. Both protocols showed a stable throughput from start simulation at 0.1 seconds until the end of simulation at 2 seconds. It is shown in figure 7.

The simulation results of medium client number i.e. 8, 16 and 32 clients shown the time response of both similarly IEEE 802.11ax and IEEE 802.11ac have few late of response time and shown have good throughput value start from a time 0.3 second, while bit rate value of IEEE 802.11ax keeps bigger than IEEE 802.11ac. It shows MIMO implementation of 802.11ax more effective than 802.11ac although both protocols

showed a stable throughput from simulation time at 0.3 seconds until the end of simulation at 2 seconds, shown in figure 8.

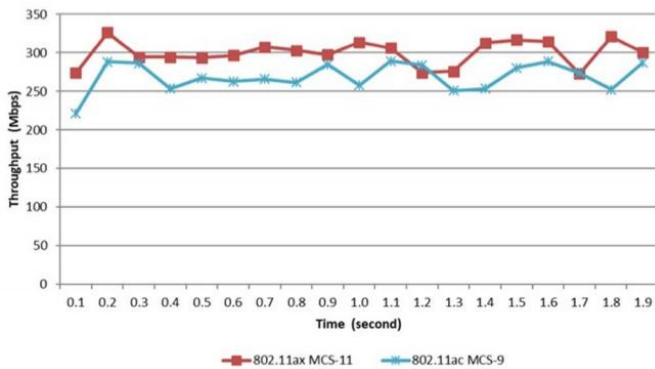

Fig. 7. Throughput 802.11ax Mcs-11 vs 802.11ac Mcs-9 with a small client number (2 and 4).

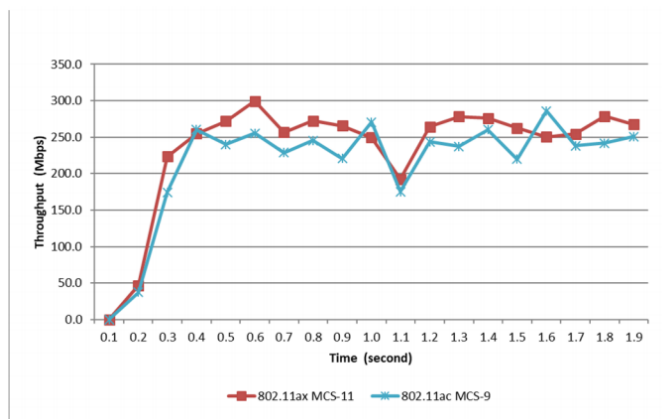

Fig. 8. Throughput 802.11ax Mcs-11 vs 802.11ac Mcs-9 with a medium client number (2 and 4).

The simulation results of big client number i.e. 64, 128, 256 and 512 clients show 802.11ac has a faster response than IEEE 802.11ax start since simulation time 0.2 second until 0.4 seconds, start from simulation time 0.5 second IEEE 802.11ax shown have bigger bit rate value than IEEE 802.11ac. IEEE 802.11ax keeps bigger throughput than IEEE 802.11ac until the end of simulation time at 2 seconds, shown in figure 9. Figure 9 shows the throughput stability comparison of IEEE 802.11ax and IEEE 802.11ac with a number of clients from 64 to 512.

IEEE 802.11ax looks to have more stable of throughput value than the throughput of 802.11ac. Figure 11 shows a difference throughput between IEEE 802.11ax vs IEEE 802.11ac. From 2 to 8 connected clients, they have almost the same throughput.

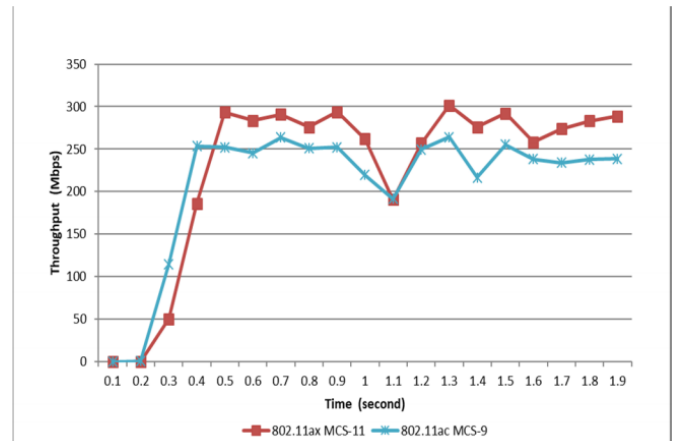

Fig. 9. Throughput 802.11ax Mcs-11 vs. 802.11ac Mcs-9 with a big client number (2 and 4).

Higher throughput difference starts at 16 clients until 512 clients. The IEEE 802.11ax has bigger throughput of 8.9 percent on average than IEEE 802.11ac.

6. CONCLUSION

Both IEEE 802.11ax Mcs-11 and IEEE 802.11ac Mcs-9 with small client number i.e. 2 and 4 clients have the same good throughput value. Simulation with the 16 to 512 clients IEEE 802.11ax has bigger throughput value than IEEE 802.11ac. At medium client number, both IEEE.802ax Mcs11 and IEEE 802.11ac Mcs-9 shown similar delay response time, but IEEE 802.11ax has a bigger throughput value than IEEE 802.11ac. A big client number, IEEE 802.11ax Mcs-11 look, has more delay response time than IEEE 802.11ac Mcs9 at the beginning for a few milliseconds, but after 0.5 ms IEEE 802.11ax shown a stable and bigger throughput value than IEEE 802.11ac that its shown decrease.

REFERENCES

- [1] 802.11ac The Fifth Generation of Wifi, Cisco white paper, 2018
- [2] 802.11ax The Sixth Generation of Wifi, Cisco white paper, 2018
- [3] Introduction to 802.11ax High-Efficiency Wireless, National instruments, 2019
- [4] Teuku Yuliar Arif and Riri Fitri Sari, Performance comparison of video traffic over WLAN IEEE 802.11e and IEEE 802.11n, in Ubi-comm the fourth international conference on ubiquitous mobile computing, systems, services and technologies, 2010
- [5] Adian Fatchur Rochim and Riri Fitri Sari, Performance comparison of IEEE 802.11n and IEEE 802.11ac, in International conference on computer, control, informatics and its application, 2016

- [6] Y. Qin, W. Yang, Y. Ye, and Y. Shi, "Analysis for TCP in data center networks: Outcast and Incast," *J. Netw. Comput. Appl.*, vol. 68, pp. 140–150, 2016
- [7] S. Utsumi and S. M. S. Zabir, "A new high-performance TCP friendly congestion control over wireless networks," *J. Netw. Comput. Appl.*, vol. 41, no. 1, pp. 369–378, 2014.
- [8] X. Wang and D. Y. Eun, "Local and global stability of TCPnewReno/RED with many flows," *Comput. Commun.*, vol. 30, no. 5, pp. 1091–1105, 2007.
- [9] Oran Sharona, Yaron Alpert, *MAC level Throughput comparison: 802.11ac vs. 802.11n*, Elsevier, 2014
- [10] Oran Sharona, Yaron Alpert, *The combination of QoS, aggregation and RTS/CTS in Very High Throughput IEEE 802.11ac networks*, Elsevier, 2015
- [11] Hyunwoo Choi, Taesik Gong, Jaehun Kim, Jaemin Shin, Sung-Ju Lee, *Use MU-MIMO at your own risk — Why we don't get Gb/s Wi-Fi*, Elsevier, 2018
- [12] Elsevier, 2018
- [13] Boris Bellalta, Luciano Bononi, Raffaele Brunoc, Andreas Kessler, *The next generation IEEE 802.11 Wireless Local Area Networks, Current status, future directions and open challenges*, Elsevier, 2015
- [14] Boris Bellalta, Katarzyna Kosek-Szott, *AP-initiated multi-user transmissions in IEEE 802.11ax WLANs*, Elsevier, 2018.