

Design and Analysis of a Typical Grid Fin for Aerospace Application

Priyanka V V¹, Dr. Shashi Bhushan Tiwari², Prashanthan A³, B Mary Sonia George⁴

¹PG Student, Dept of Civil Engineering, Sree Narayana Guru College of Engineering & Technology, Kerala, India

²Scientist/Engineer, Vikram Sarabhai Space Centre, Kerala, India

³Scientist/Engineer, Vikram Sarabhai Space Centre, Kerala, India

⁴Assistant Professor, Dept. of Civil Engineering, Sree Narayana Guru College of Engineering & Technology, India

Abstract - Grid fins (or lattice fins) are a type of flight control surface used on rockets and bombs, which consist of lattice shaped structure attached together to form a fin. The major advantage of such fin is that, they can be easily assembled to the launch vehicle and can be operated for stipulated time duration whenever required. The deployment mechanism imparts more dynamic loads on to the fin and so the structural dynamics play a vital role in its design. To get maximum stability, the fin mass should be minimum as possible by the functional point of view. But the structure should withstand all the static and dynamic loads for the operation period. The lattice structure makes the structure more complex as per the realization aspects. A limit state design methodology is attempted for this Titanium grid fin structure to arrive at an optimum structural configuration. The design optimization and validation through finite element analysis is carried out using in house developed finite element FEAST (Finite Element Analysis of Structures) software by Vikram Sarabhai Space Centre (VSSC).

Key Words: Grid Fin, Flight control surface, Deployment mechanism, stipulated time, limit state design, methodology, optimum, finite element, FEAST software

1.0 INTRODUCTION

The grid fin is a lattice structure. It is used to provide the stability and control of launch vehicle and missiles. Advantages of the grid fin over the conventional planar fins are higher strength to-weight ratio and lower hinge moment. Therefore it can contribute to mitigate the requirements for a control actuator of the fin. On the other hand, its higher drag is a significant disadvantage. Grid fins are widely used in Crew Escape Systems (CES) of manned space missions of many countries.

During the normal launch phase grid fins function as aero stabilizers. Then they are stowed against the cylindrical body which helps to reduce overall dimension of the vehicle and minimize aerodynamic disturbance. In case of launch abort situation for effective functioning the grid fins deploy to achieve the required static margin for the control of the crew escape systems.

In the current study, grid fin is configured with Titanium alloy. The structural design of the grid fin is carried out for the aero loads and moments. The design is validated through

analysis. The FEAST software developed by VSSC is used for the analysis of grid fin. A typical grid fin configuration is shown in Figure 1.

1.1 Scope and Objectives of the Study

The main objectives and scope of the study are

- To design the Grid fin structure using Limit State Method.
- To analyze Titanium Grid fin structures of an Advance Launch Vehicle using FEAST software in house developed by VSSC.
- Design Optimization of grid fin for the different materials subjected to design constraints.

2.0 DESIGN OF GRID FIN

The Grid fin structure is designed using Limit State Method. Yield stress of Titanium is considered as 880 N/mm² and Partial safety factor of Titanium against yielding as 1.035, which is derived from tested yield and ultimate strength properties. Design forces are evaluated from the simplified beam model of the grid fin structure with assumed section dimensions. Detailed design computation for the grid fin panel sections are given in Table 1. The section requirement of each lattice panel of grid fin subjected to axial load and bending moments are calculated and the calculation of one typical panel of 8 X 150 mm cross section is shown below:

CASE 1-MAXIMUM AXIAL FORCE CONDITION

- Maximum axial force = 2486.1 N
- Bending Moment (BM1) = 523.75 Nmm
- Bending Moment (BM2) = 2370.25 Nmm
- Factored axial force (N) = 3729.15 N
- Factored Bending Moment (BM1) My = 785.62Nmm
- Factored Bending Moment (BM2) Mz = 3555.375Nmm
- Breadth = 8mm
- Depth = 150mm
- Design strength in tension (N_d) = A_gf_y/γ₀

where, A_g = gross section area of cross section
 f_y = yield stress
 γ₀ = partial safety factor in yielding
 N_d = 8x150x880/1.035 = 1020290 N

Design strength under corresponding moment alone (M_{dy}, M_{dz})

$$M_{dy} = \beta_b * Z_p * f_y / \gamma_0 = 1 \times 8 \times 150^2 \times 880 / (4 \times 1.035) = 38260870 \text{ Nmm}$$

$$M_{dz} = \beta_b * Z_p * f_y / \gamma_0 = 1 \times 150 \times 8^2 \times 880 / (4 \times 1.035) = 2040580 \text{ Nmm}$$

where, $\beta_b = 1$, for plastic and compact section
 Z_p = Plastic section modulus of Cross section
 f_y = Yield stress of material
 γ_0 = Partial safety factor

Design reduced flexural strength under combined axial force and respective uniaxial moment acting alone (M_{ndy}, M_{ndz})

$$M_{ndy} = M_{dy}(1-n^2) = 38260870(1-0.00365^2) = 38260358 \text{ Nmm}$$

$$M_{ndz} = M_{dz}(1-n^2) = 2040580(1-0.00365^2) = 2040552 \text{ Nmm}$$

where, $n = N/N_d$

Design Check1

In the design of members subjected to combined axial force (tension or compression) and bending moment, the following should be satisfied:

$$(M_y/M_{ndy})^{\alpha_1} + (M_z/M_{ndz})^{\alpha_2} \leq 1$$

where, M_y = Factored Bending Moment

M_{ndy} = Design reduced flexural strength under combined axial force and uniaxial moment acting alone

$$\alpha_1 = \text{for solid rectangle} = 1.73 + 1.8n^3$$

M_z = Factored Bending Moment

M_{ndz} = Design reduced flexural strength under combined axial force and respective uniaxial moment acting alone.

$$\alpha_2 = \text{for solid rectangle} = 1.73 + 1.8n^3$$

$$(M_y/M_{ndy})^{\alpha_1} + (M_z/M_{ndz})^{\alpha_2} \leq 1$$

$$(785.62/38260358)^{1.73} + (3555.375/2040552)^{(1.73)} = 1.69E-5 \leq 1$$

Hence the design check is satisfied, section is safe.

Design Check 2

Conservatively, the following equation may also be used under combined axial force and bending moment

$$N/N_d + M_y/M_{dy} + M_z/M_{dz} \leq 1$$

Where N = Factored axial force
 N_d = Design strength in tension
 M_y = Factored Bending Moment
 M_{dy} = Design strength under corresponding moment alone
 M_z = Factored Bending Moment
 M_{dz} = Design strength under corresponding moment alone

$$N/N_d + M_y/M_{dy} + M_z/M_{dz} \leq 1$$

$$(2729.15/1020290) + (785.62/38260870) + (3555.375/2040580) = 0.0054 \leq 1$$

Hence the design check is verified.

Similarly design verification for maximum bending moment BM1 and BM2 conditions are also completed to check the design adequacy of the section dimensions.

CASE 2 - MAXIMUM BENDING MOMENT (BM1)

Axial force	= 811.05 N
Bending Moment (BM1)	= 6258.41 Nmm
Bending Moment (BM2)	= 8721.38 Nmm
Factored axial force	= 1216.58 N
Factored Bending Moment (BM1)	= 9387.62 Nmm
Factored Bending Moment (BM2)	= 13082.07 Nmm
Breadth (b)	= 8 mm
Depth (d)	= 150 mm
Design strength in tension (N _d)	= 1020290 N
M _{dy}	= 38260870 Nmm
M _{dz}	= 2040580 Nmm
M _{ndy}	= 38260815 Nmm
M _{ndz}	= 2040577 Nmm
n	= 0.0012
α_2	= 1.73
α_1	= 1.73

DESIGN CHECKS

Design Check1

$$(M_y/M_{ndy})^{\alpha_1} + (M_z/M_{ndz})^{\alpha_2} \leq 1$$

$$(9387.62/38260815)^{(1.73)} + (13082.07/2040577)^{(1.73)} = 0.0002 \leq 1$$

Hence design check is verified.

Design Check2

$$N/N_d + M_y/M_{dy} + M_z/M_{dz} \leq 1$$

$$(1216.58/1020290) + (9387.62/38260870) + (13082.07/2040580) = 0.0078 \leq 1$$

Hence the design check is satisfied, section is safe.

CASE 3 - MAXIMUM BENDING MOMENT (BM2)

Axial force	= 2350.18 N
Bending Moment (BM1)	= 396.38 Nmm

Bending Moment (BM2)	= 1034790 Nmm
Factored axial force	= 594.57 N
Factored Bending Moment (BM1)	= 594.57 Nmm
Factored Bending Moment (BM2)	= 1552185 Nmm
Breadth(b)	= 8 mm
Depth (d)	= 150 mm
Design strength in tension (N _d)	= 1020290 N
M _{dy}	= 38260870 Nmm
M _{dz}	= 2040580 Nmm
M _{ndy}	= 38260413 Nmm
M _{ndz}	= 2040555 Nmm
n	= 0.0035
α ₂	= 1.73
α ₁	= 1.73

DESIGN CHECKS

DESIGN CHECK1

$$\frac{(M_y/M_{ndy})^{\alpha_1} + (M_z/M_{ndz})^{\alpha_2}}{(594.57/38260413)^{(1.73)} + (1552185/2040555)^{(1.73)}} \leq 1$$

$$= 0.6230 \leq 1$$

Hence design is verified.

DESIGN CHECK 2

$$N/N_d + M_y/M_{dy} + M_z/M_{dz} \leq 1$$

$$\frac{(3525.27/1020290)}{(1552185/2040580)} + \frac{(594.57/38260870)}{1} + \frac{(594.57/38260870)}{1} = 0.7641 \leq 1$$

Hence section of lattice panel taken is adequate.

3.0 ANALYSIS OF GRID FIN

3.1 Finite Element Modelling

Grid fin of size 1992 mm x 1459 mm x 150 mm along with damper was modelled using FEAST software. The grid fin is idealized with general plate shell element. The grid fin interface bracket is modeled using 3 –D solid element. The grid fin is connected to the bracket at bolt locations using beam element. Damper is modelled as spring element and connected to the grid fin through a lug joint. Material properties of Titanium (Ti6Al4V) are used for the grid fin and interface brackets. Interface fasteners are of A286 property class high strength steel. Displacement boundary conditions (U_x = U_y = U_z = 0) are specified at one end of the

damper and at bracket interface locations. The finite element model is shown in Figure 2. Aerodynamic forces are specified as distributed loads on all nodes of the grid fin. Linear Static and modal dynamic analyses were performed to estimate stress and deflection patterns and frequencies and associated mode shapes.

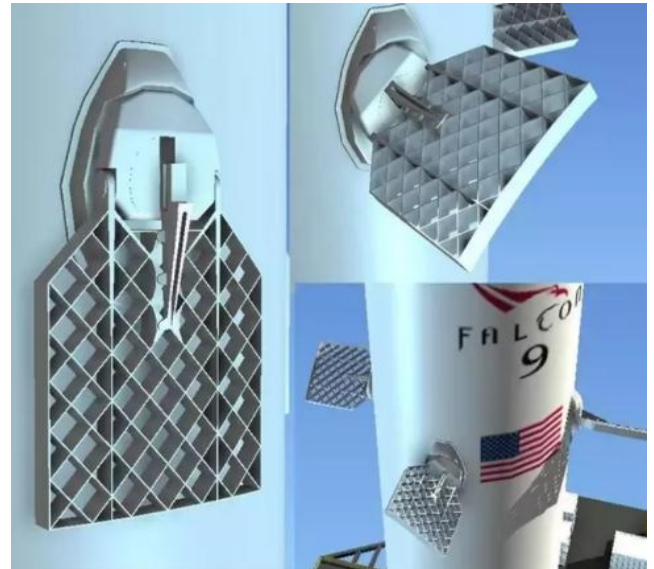

Fig - 1: Typical Grid Fin

4.0 RESULT AND DISCUSSIONS

Limit state base design approach is used to design the grid fin structure including interface brackets. The stress resultants like bending moments, shear forces, torsion and axial forces are estimated using beam element based finite element analysis. Partial safety factor for titanium is derived from test results. Design parameters for the final grid fin components are given in Table-1. Static and modal analysis is carried out to validate the design. Linear static analysis is carried out to estimate deformation and stress over the grid fin structural parts. The deflection, Von Mises stress, Maximum shear stress are shown in Figures 2 – 5. The first two mode shapes are shown in Figures 6-7. Maximum resultant deflection at grid fin tip is 36.7 mm. Maximum Von-Mises stress out of all the layers are 182 MPa and maximum shear stress is 93.87 MPa. These stress values are much less than the material capacity of 880 MPa and the design is very safe and having sufficient design margin. The lowest natural frequency is 18.25 Hz and is first cantilever bending mode. The second mode is 44.89 Hz, and is identified as first torsion mode. The overall weight of the grid fin structure is 120 kg.

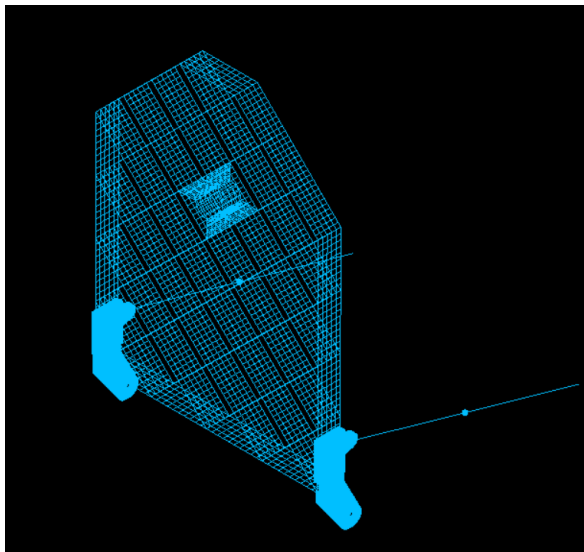

Fig - 2: Grid fin Finite Element Model (FEAST)

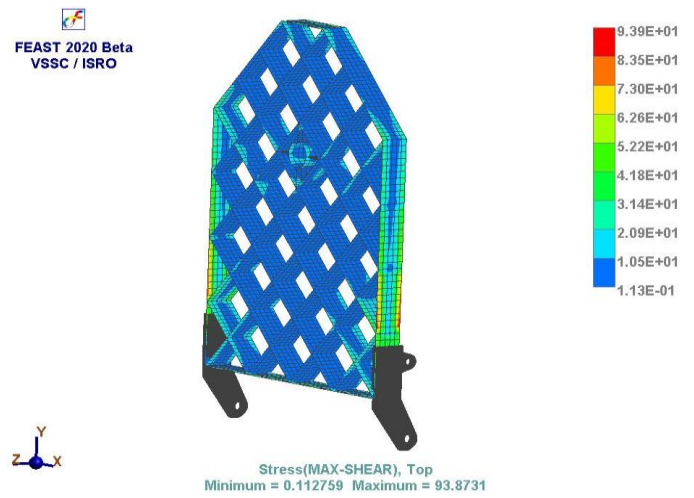

Fig - 5 : Maximum shear stress of grid fin (plate model)

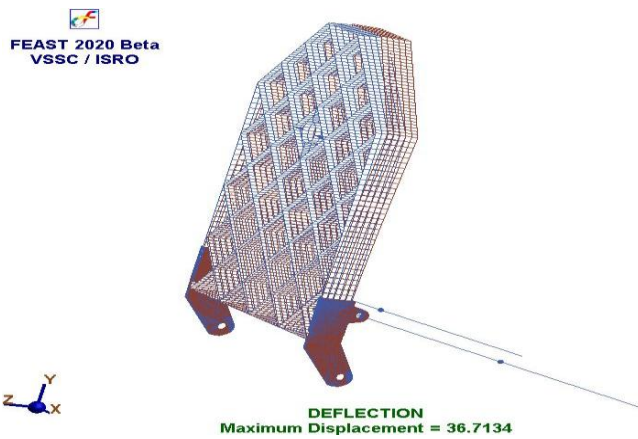

Fig - 3 : Deflection of grid fin (Plate model)

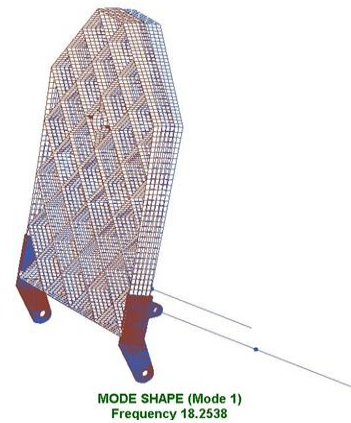

Fig - 6 : Mode shape 1 of plate model

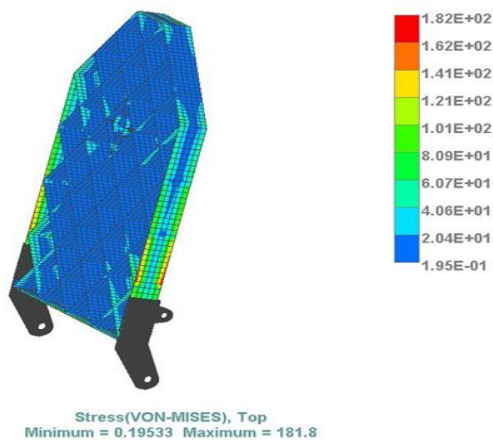

Fig - 4 : Von Mises stress of grid fin (plate model)

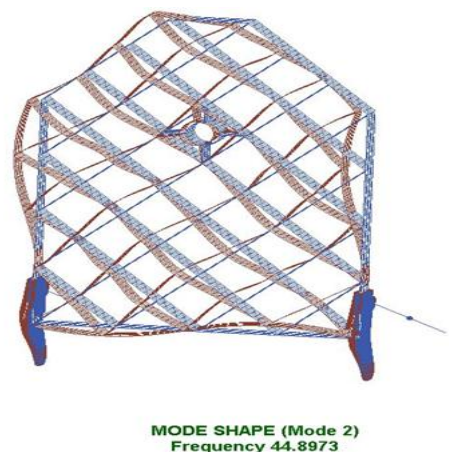

Fig - 7 : Mode shape 2 of plate model

Table -1: Design result of grid fin

SET (mm)	MAXIMUM AF OR MAXIMUM BM	AXIAL FORCE (N)	BM1 (Nmm)	BM2 (Nmm)	FACTORED AF(N)	FACTORED BM1(My) (Nmm)	FACTORED BM2(Mz) (Nmm)	b(mm)	d(mm)	Nd	Mdy (Nmm)	Mdz (Nmm)	N/Nd + My/Mdy +Mz/Mdz ≤1	n	Mndy (Nmm)	Mndz (Nmm)	alpha	(My/Mdy)^alpha 1 +(Mz/Mndz)^alpha a2 ≤ 1
SET 2 (8X150)	MAX AF	2486.10	523.75	2370.25	3729.15	785.62	3555.375	8	150	1020290	38260870	2040580	0.0054	0.0037	38260358	2040552	1.73	1.69E-05
	MAX BM1	811.05	6258.41	8721.38	1216.58	9387.62	13082.07	8	150	1020290	38260870	2040580	0.0078	0.0012	38260815	2040577	1.73	0.0002
	MAX BM2	2350.18	396.38	1034790	3525.27	594.57	1552185	8	150	1020290	38260870	2040580	0.7641	0.0035	38260413	2040555	1.73	0.6230
SET 3 (5X150)	MAX AF	2517.99	805.88	3046.41	3776.99	1208.82	4569.615	5	150	637681.2	23913043	797101.4	0.0117	0.0059	23912205	797073.5	1.73	0.0001
	MAX BM1	1899.66	4896.54	2943.29	2849.49	7344.81	4414.935	5	150	637681.2	23913043	797101.4	0.0103	0.0045	23912566	797085.5	1.73	0.0001
	MAX BM2	2132.40	892.44	13745.5	3198.60	1338.66	20618.25	5	150	637681.2	23913043	797101.4	0.0309	0.0050	23912442	797081.4	1.73	0.0018
SET 4 (10X150)	MAX AF	168.64	1239.12	63077.2	252.96	1858.68	94615.8	10	150	1275362	47826087	3188406	0.0299	0.0002	47826085	3188406	1.73	0.0023
	MAX BM1	35.11	6376.34	175220	52.66	9564.51	262830	10	150	1275362	47826087	3188406	0.0827	4.13E-05	47826087	3188406	1.73	0.0133
	MAX BM2	35.11	6376.34	175220	52.66	9564.51	262830	10	150	1275362	47826087	3188406	0.0827	4.13E-05	47826087	3188406	1.73	0.0133
SET 5 (20X150)	MAX AF	5807.99	51252.9	7792830	8711.99	76879.35	11689245	20	150	2550725	95652174	12753623	0.9208	0.0034	95651058	12753474	1.73	0.8601
	MAX BM1	1408.94	128084	7682350	2113.41	192126	11523525	20	150	2550725	95652174	12753623	0.9064	0.0008	95652108	12753614	1.73	0.8391
	MAX BM2	5807.99	51252.9	7792830	8711.99	76879.35	11689245	20	150	2550725	95652174	12753623	0.9208	0.0034	95651058	12753474	1.73	0.8601
SET 6 (17X150)	MAX AF	3254.30	5251.32	5863790	4881.45	7876.98	8795685	17	150	2168116	81304348	9214493	0.9569	0.0023	81303936	9214446	1.73	0.9227
	MAX BM1	536.11	53701.50	66204.6	804.16	80552.25	99306.9	17	150	2168116	81304348	9214493	0.0121	0.0004	81304337	9214491	1.73	0.0004
	MAX BM2	3254.30	5251.32	5863790	4881.45	7876.98	8795685	17	150	2168116	81304348	9214493	0.9569	0.0023	81303936	9214446	1.73	0.9227
SET10 (25X128.2)	MAX AF	16161.70	521276	138789	24242.55	781914	208183.5	25	128.2	2725024	87337024	17031401	0.0301	0.0089	87330112	17030053	1.730001	0.0008
	MAX BM1	16161.70	521276	138789	24242.55	781914	208183.5	25	128.2	2725024	87337024	17031401	0.0301	0.0089	87330112	17030053	1.730001	0.0008
	MAX BM2	16161.70	521276	138789	24242.55	781914	208183.5	25	128.2	2725024	87337024	17031401	0.0301	0.0089	87330112	17030053	1.730001	0.0008

Table-2 :Frequency analysis of plate model

MODE	FREQUENCY(Hz)
1	18.254
2	44.897
3	70.650
4	77.641
5	82.509
6	93.421
7	120.352
8	120.653
9	156.417
10	158.624

5.0 CONCLUSIONS

The following conclusion can be drawn from the present investigation of the Grid fin.

- The grid fin is designed using Limit State Method.
- The static and model analysis is carried out to validate the design.
- Maximum normal deflection is 36.7 mm.
- The slope of the grid fin is 0.45 deg which is within the specified value of 1 degree.
- Maximum Von Mises Stress 182 MPa and well within the allowable limit of 880 MPa
- The fundamental frequency of the grid fin is found to be 18.25 Hz and is first cantilever bending mode.
- The mass of the grid fin is 120 kg

6.0 REFERENCES

- [1] William D. Washington and Mark S. Miller “Grid Fins - A New Concept for Missile Stability and Control”, (1993), Page No.1-11.
- [2] Rakesh Kumar, Ajay Misra, and A.K. Ghosh, “Modelling of Cascade Fin Aerodynamics Near Stall using Kirchhoffs Steady-state Stall Model”, Defence Science Journal, Volume 61, 2011, Page No.157- 164.
- [3] G A Faza, H Fadillah, F Y Silitonga, Mochamad Agoes Moelyadi, “Study of Swept Angle Effects on Grid Fins

Aerodynamics Performance”, 5th International Seminar of Aerospace Science and Technology, 2013 Page No.1-10.

[4] Prashanth H S, Prof. K S Ravi, Dr G B Krishnappa, „Aerodynamic Characteristics of G16 Grid Fin Configuration at Subsonic and Supersonic Speeds”, International Journal of Engineering Research and General Science, Volume 2, 2015, Page No.129-135.

[5] Jian-Zhong CHEN,Pei-Qing LIU, “Test Technique Research for the Hinge Moment of A Grid Fin In High Speed Wind Tunnel”, 2014 Page No.480-484.

[6] Nirmal Kumar Balaguru, “Computational Grid-Fin Analysis”, International Journal of Engineering Research & Technolog, 2015, Page No.362-364.

[7] Zubairkhan Kittur,Amit Bahekar,“CFD Analysis of Grid Fin Application on Missile in Supersonic Flow Regime”, Research Journal of Recent Sciences, 2016 Page No .51-56.

[8] T.S.A. Suria Kumari, and K. Prudhvi Raj Reddy, “Enhancing the aerodynamic efficiency of Missile with altered grid fins in subsonic flow conditions using ANSYS Workbench”, Journal of Chemical and Pharmaceutical Sciences ISSN, 2016,Page No .189-195.

[9] R. Srinivasan1, V. Vijayan and K. Sridhar, “Computational Fluid Dynamic Analysis of Missile with Grid Fins”, 2017,Page No .33-39.

[10] Md Nizam Dahalan, Ahmad Fitri Suni, Iskandar Shah Ishak, Nik Ahmad Ridhwan Nik Mohd, Shabudin Mat, “Aerodynamic Study of Air Flow over A Curved Fin Rocket”, Journal of Advanced Research in Fluid Mechanics and Thermal Sciences, 2017, Page No.46-58.

[11] Ajayakumar AG, Vipin G P, Sarathchandradas, “Structural Design and Mass Optimisation of Grid Fin For Launch Vehicles”, International Research Journal of Engineering and Technology, 2018, Page No.3837-3842.

[12] Nayhel Sharma, Rakesh Kumar,“ Missile Grid Fins Analysis using Computational Fluid Dynamics: A Systematic Review”, 2019, Page No .151-169.