

Modelling and Analysis of Dickson Converter for PV Connected Micro-Grid System using Hysteresis Current Control Technique

T. V. Viknesh¹, V. Manikandan²

^{1,2}Department of Electrical and Electronics Engineering, Coimbatore Institute of Technology, Coimbatore-641014, India

Abstract - This paper proposes a hybrid system consisting of a photovoltaic (PV) array and rechargeable battery integrated to the distribution grid with the scope to perform load sharing and reducing demand with the distribution grid. The PV array, charge controller and the lead acid battery are connected to the dc-side of the voltage source inverter (VSI) through improved Dickson converter. Further incremental conductance MPPT control algorithm is developed for 1 Soltech 230-WP solar PV array and checked for different irradiance and temperature. Meanwhile Hysteresis current control method, the most important current control strategy is applied for VSI in this paper. The performance of system is analyzed using Matlab/Simulink to verify the output efficiency of the proposed system.

Key Words: Modelling, Dickson converter, Photovoltaics, micro grid, Hysteresis current

1. INTRODUCTION

Nowadays electricity power network has becoming critical issue on maintaining its reliability, sustainability and power quality [1]. The current electric power grids are growing old in this developing world. As a result of this aging grid and old infrastructures become more prominent as the power to demand ratio increases. These former equipment's are prone to failures, and sometimes the old power planning fails to satisfy necessities [2]. So currently the researchers of all country are working for the update called micro grid and smart grid to overcome the current challenges of existing power grid. So in recent years the concept of distributed generation (DG) have increased rapidly due to driving forces such as fuel prices, reducing carbon emission and advancement in technology [4]. When the distributed energy resources (DER), which usually have power rating are of few kilowatts, are connected to the medium or low voltage distribution levels of the power networks, consumers are able to benefit from the increased reliability and reduction in total energy loss [5]. Solar photovoltaic (PV) power has pulled out a greater attention among other DER sources because of its advantages. PV enables clean, renewable, zero-emission electricity production which is completely fighting against future raise in fossil fuel price, which is unlike other DER such as fuel cells and micro-turbines. PV arrays can either be designed as stand-alone and grid-connected systems. Stand-alone systems are equipped with energy storage devices such as batteries to store electricity for sunless hours and act as energy buffers between the input power from the solar cell and the output power to the load. In grid-connected operation, the PV system supplements the grid power and it represents the fastest growing sector today [3].

This paper proposes integration of improved Dickson converter within micro grid comprising of PV array, charge controller, lead acid battery. The main advantage of Dickson converter is they can be used in high power applications [12]. Hysteresis current control technique is used as controller for inverter output. Meanwhile novel INC-mppt technique is used as a closed loop control with PV array for power converter. Load of 1.5 kVar is used and simulation is done using Matlab 2014a and results are shown under section E. The rest of paper is organized as follow under section I the sub-categories are Section A is modelling of PV array, Section B is modelling of charge controller, section C is of novel Incremental conductance MPPT, section D is modelling of Dickson converter, section E is Inverter current control and section II contains all necessary simulation results of proposed method and section III and IV are conclusion and references respectively.

2. STRUCTURE OF PROPOSED GRID CONNECTED PV SYSTEM

Fig 1 shows the block diagram of proposed PV connected grid system. The system composes of PV array, charge controller, MPPT control, Rechargeable batteries connected with charge controller, DC-DC boost converter i.e. Dickson converter and finally DC side of power converter connected voltage source inverter. The Mppt block shown in fig.5 controls Dickson converter while inverter is controlled using hysteresis control method with the reference current I_{abc}^* as shown in fig 16. The output of the VSI is linked with LC filter represented by L_f and C_f as in fig 9 to eliminate the high switching frequency harmonics generated by the VSI. When the grid is required to be isolated from the whole system, which can occur unintentionally due to a fault or intentionally due to a scheduled maintenance, the circuit breaker operates to disconnect the distribution grid from the whole system.

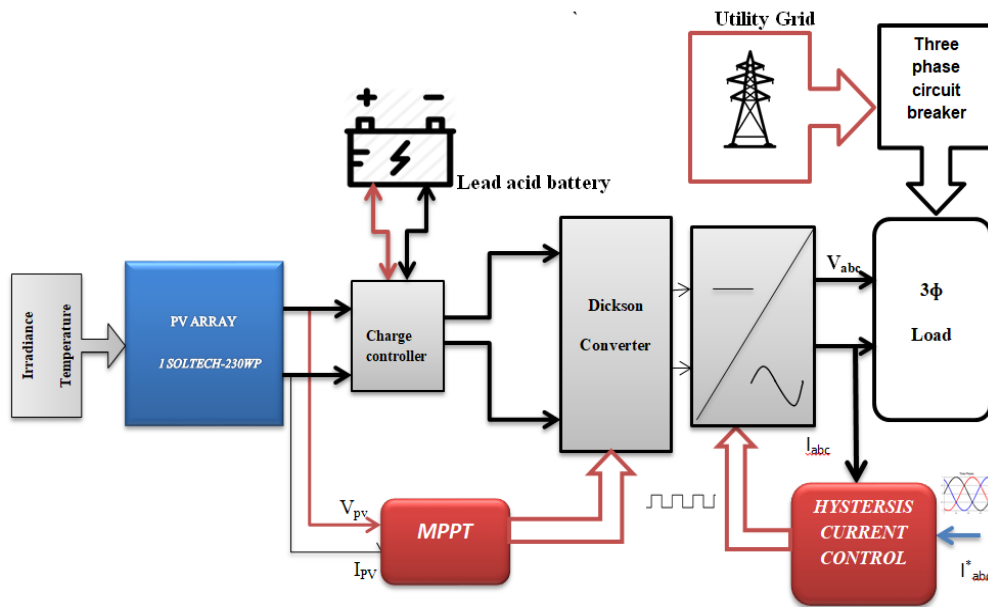

Fig-1 Block diagram of proposed method

2.1 Modelling of Photovoltaic array

PV cells are grouped in larger units called PV modules which are further interconnected in a parallel-series configuration to form PV arrays[7]. In this paper one diode model with series and parallel resistance is considered as shown in fig (2). [6]The current source I_{ph} represents photovoltaic current of a cell. R_{sh} and R_s represents intrinsic shunt and series resistance respectively. Usually R_{sh} is greater than R_s , so they are neglected in this analysis.

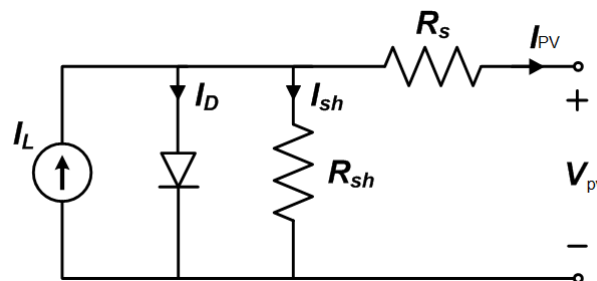

Fig-2 Equivalent circuit of one diode PV model

$$I_{pv} = I_{ph} - (I_D + I_p) \quad (1)$$

I_p is current flowing through R_p

$$R_p \cdot I_p = V_{pv} + I_{pv} \cdot R_s \quad (2)$$

$$I_{pv} = I_{ph} - I_0 \left[\exp\left(\frac{V_{pv} + I_{pv} \cdot R_s}{V_t}\right) - 1 \right] - \frac{V_{pv} + I_{pv} \cdot R_s}{R_p} \quad (3)$$

V_{pv} and I_{pv} are voltage and current output of panel respectively.

$$I_{ph} = I_{sc} + K_i (T - 298) \cdot \frac{\lambda}{1000} \quad (4)$$

$$I_{rs} = \frac{I_{sc}}{\exp\left(\frac{q N_s K A T}{V_{oc}}\right) - 1} \quad (5)$$

Here I_{ph} is Photovoltaic current, I_{sc} is short circuit current

$$I_0 = I_r \left(\frac{T}{T_r}\right)^3 \cdot \exp\left[\frac{q \cdot E_{g0}}{B \cdot K} \left(\frac{1}{T_r} - \frac{1}{T}\right)\right] \quad (6)$$

Here N_s N_p is number of panels connected in series and parallel respectively.

Table 1. PV array specifications

Specifications	Ratings
V_{mpp}	30
I_{mpp}	7.07
V_{oc}	37
I_{sc}	8.18
$N_s N_p$	2,4
Maximum Power	229
Irradiance	$\sim 1000W/m^2$
Temperature	$\sim 25^{\circ}C$

2.2 Modelling of Charge controller

The main role of charge controller is to monitoring and control of power flow from renewable energy source to battery. The direct connection of the PV module and the battery reduces the energy conversion efficiency of the PV module [9]. Due to inconstant irradiance and temperature, the power from PV array leads to battery damage and tends to reduce the life cycle of battery. So the charge controller is employed to protect the battery from over charging condition [8]. As per the specifications of battery mentioned in **table 2** .The charge controller tends to control power and injects to the battery in order to avoid hazardous condition of whole system.

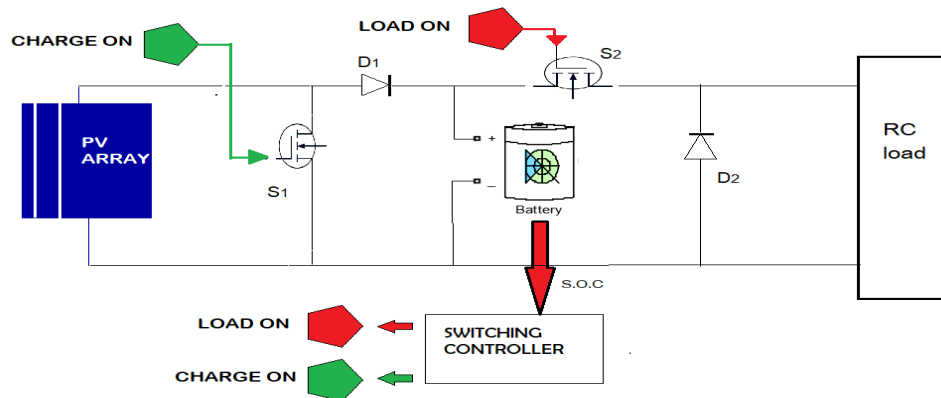

Fig-3 Equivalent circuit of charge controller

The charge controller is categorised into series and shunt charge controllers. The fig 3 shows the circuit diagram of shunt charge controller. The function of shunt charge controller depends on switching signal provided to the circuit. Furthermore, automatic function of switches, the program has been developed by considering SOC of battery. When battery SOC is 80% then S_1 is turned on and battery gets charged to 80% for a time t_1 . Once battery gets charged S_1 is turned off, S_2 is turned ON, so that battery gets discharge to 20% for time t_2 . Then with the help of Charge controller the continuous supply of power is provided to load for any instant of time. Lead acid batteries have been used in various off-grid and standalone power systems for decades, and are one of the most commonly offered product options in home solar energy storage systems – and are also usually the most affordable. In this paper Lead acid-AGM type batteries are considered because of their safety purposes and sensitivity to temperature. These batteries have an advantage that when maintained properly, they will function at 80-90% efficiency. The battery discharge characteristics for voltage vs Time and Ampere-hour are shown in fig 17 and 18 respectively. So an algorithm is developed in Matlab for charge controller to avoid over charge conditions. It is important to maintain a full charge whenever possible, because it will extend its life and maintain a higher efficiency. Charge controllers with solar panels are employed so they don't over charge the battery. The battery specifications are provided in table below

Table 2. Battery specifications

Type	Lead acid battery
Rated capacity	12 Ah
Nominal voltage	150 v
Full charged voltage	~164v
Maximum capacity	12.5 v
SOC	80%

2.3 Increment conductance MPPT

Due to the varying irradiance and temperature PV modules experience different power-voltage characteristics. With application of MPPT algorithm, [10] MPP can be observed and controlled. In this paper INC MPPT algorithm is used to provide gate signal to the Dickson converter. The simple flow chart for MPPT is shown below

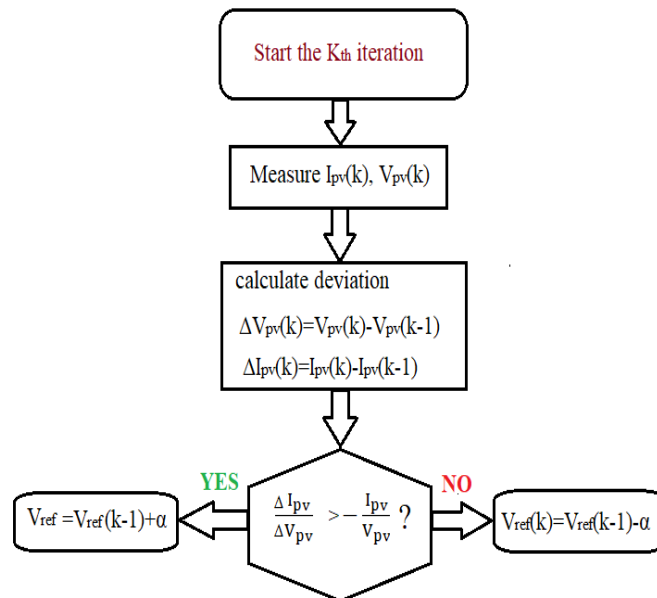

Fig-4 Flow chart of INC-MPPT algorithm

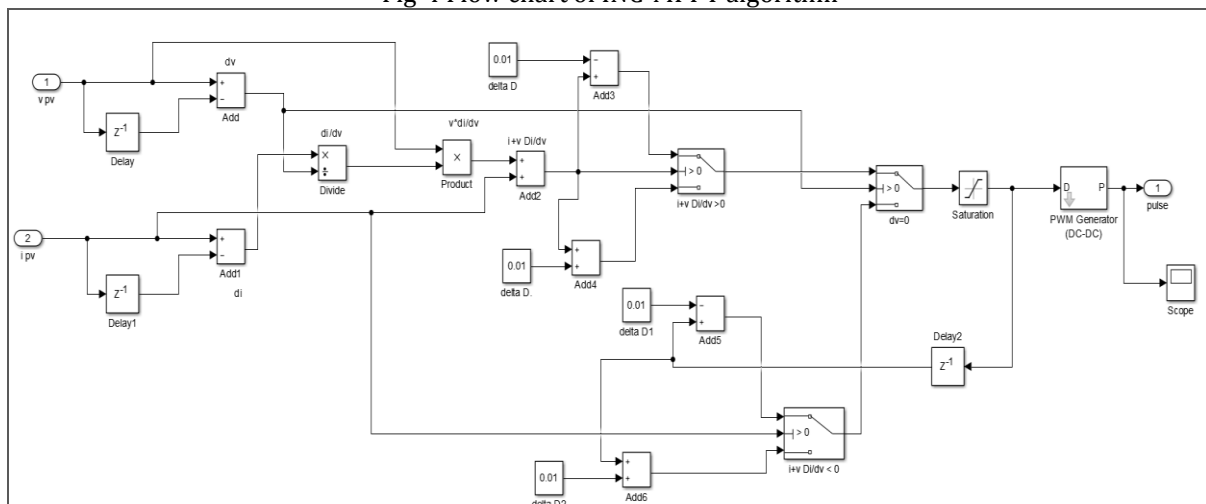

Fig-5 Simulink model of INC-MPPT algorithm

At maximum power point of PV, it indicates

$$\frac{\delta P_{pv}}{\delta V_{pv}} = 0 \quad (8)$$

$$P_{pv} = V_{pv} I_{pv}$$

$$\frac{\delta I_{pv}}{\delta V_{pv}} = -\frac{I_{pv}}{V_{pv}} \quad (9)$$

The INC mppt method operates by measuring the PV array power i.e. voltage and current. The values in equation are compared and control the power converter as per fig4. The fig 5 shows Matlab-Simulink circuit of the INC mppt[11] for extraction of maximum power. The iteration is repeated until the difference value of equation (9) gets lower than pre-defined value.

2.4 Modelling of Proposed converter topology

In this section modelling of Improved Dickson converter is represented. The main merit of going for the Dickson converter is to reduce the voltage stress across the switches. The voltage stress is reducing by the factor of 2. [12] Since Dickson converter experience a very low voltage stress it can be used for high power applications.

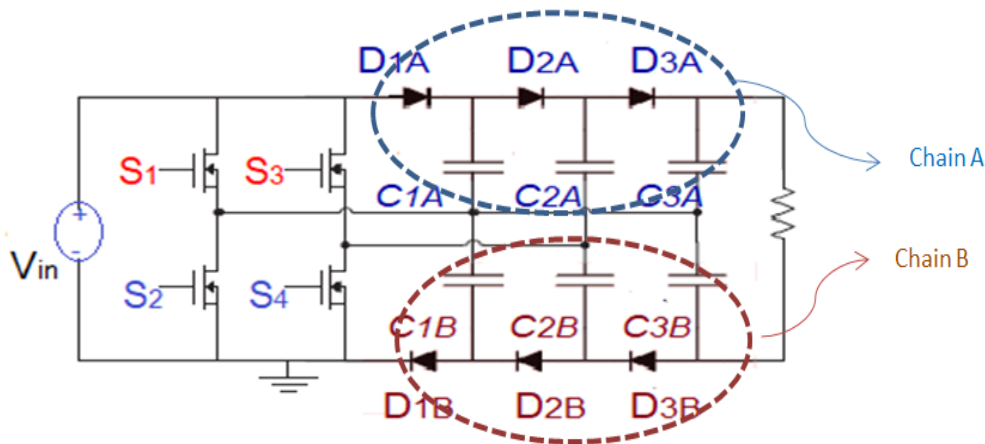

Fig-6 Improved model of Dickson converter

The improved Dickson converter is shown in fig 6. Depending on switching characteristics they are divided into 2 modes. In mode 1 S1 and S3 are turned ON and in mode 2 S2, S4 is turned ON. All the capacitor used in converter are of 0.1F and pulses for Mosfet is shown in fig 6. The equivalent circuit of mode 1 and 2 is shown in fig 7 and 8 respectively.

Mode 1

Applying KVL to mode 1

$$V_{in} - V_{c1A} = 0 \quad (6)$$

$$V_{in} + V_{c1B} - V_{c2B} = 0 \quad (7)$$

$$V_{in} + V_{c2A} - V_{c3A} = 0 \quad (8)$$

$$V_0 - V_{c3A} - V_{c3B} = 0 \quad (9)$$

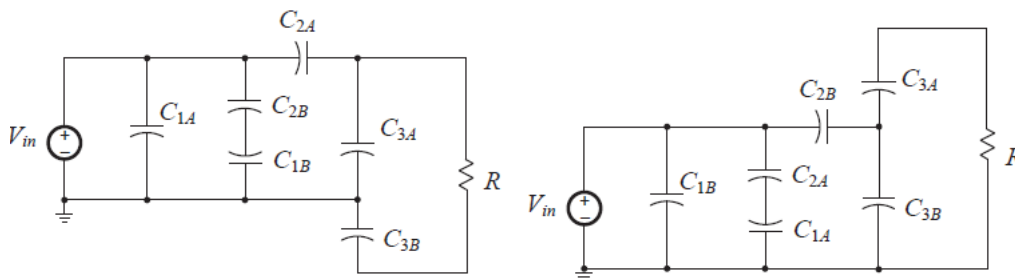

Fig 7 Equivalent circuit of Mode 1 Fig 8. Equivalent circuit of Mode 2

Mode 2

Applying KVL to mode 2

$$V_{in} - V_{c1B} = 0 \quad (10)$$

$$V_{in} + V_{c1A} - V_{c2A} = 0 \quad (11)$$

$$V_{in} + V_{c1B} - V_{c3B} = 0 \quad (12)$$

2.5 Inverter current control

Some of the novel control schemes for current [13] such as PID, hysteresis, Dead beat control are used. Current control methods are always insensitive to noise and it also provide switching signal to inverter, in accordance to reference input. [14] Self commutated inverter is employed in all inverter area because of its power handling capability i.e. it can handle power of 1-100Kw by using this current control schemes. Grid connected mode operation is comparatively easier than stand-alone mode

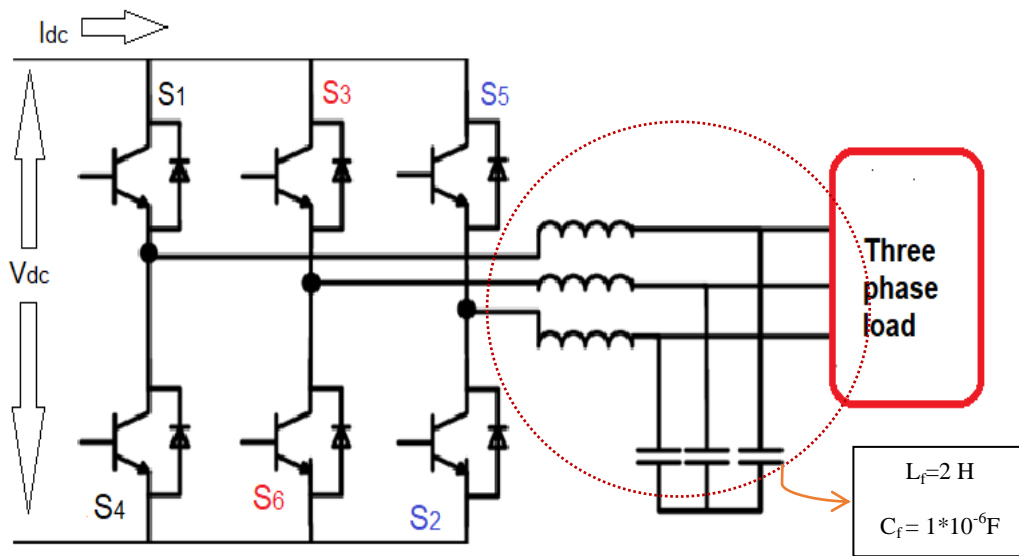

Fig- 9 Power circuit of inverter

Hysteresis current control is used in this paper for controlling the current flow from LC filter. [15] The actual current I_{abc} is measured and compared with reference signal I^*_{abc} as shown in fig16. The working of hysteresis controller is very simple compared to other controllers. When the actual current exceeds the upper limit, the negative voltage is applied to the inductor to decrease its current and when it exceeds the lower limit, positive voltage is applied then current increases and cycle continues. The gate pulse of Hysteresis current control is shown in fig (12). In this paper fixed band hysteresis controller is used, so that hysteresis bandwidth is fixed over fundamental period.

$$I_{ref} = I_{max} \sin \omega t$$

$$I_{up} = I_{ref} + H$$

$$I_{low} = I_{ref} - H$$

Here I_{up} and I_{low} is upper and lower band respectively. H is hysteresis band.

The performance of hysteresis controller has a good response towards load current. Since variable switching frequency causes resonance problem and it is not taken into account in this paper. Meanwhile THD of inverter voltage and current has been drastically reduced to 7.6% shown in fig 22.

Table 3 Hysteresis loop specifications

Reference current	1A
Hysteresis Bandwidth	±0.3
Load resistance	10000Ω
Load capacitance	100F

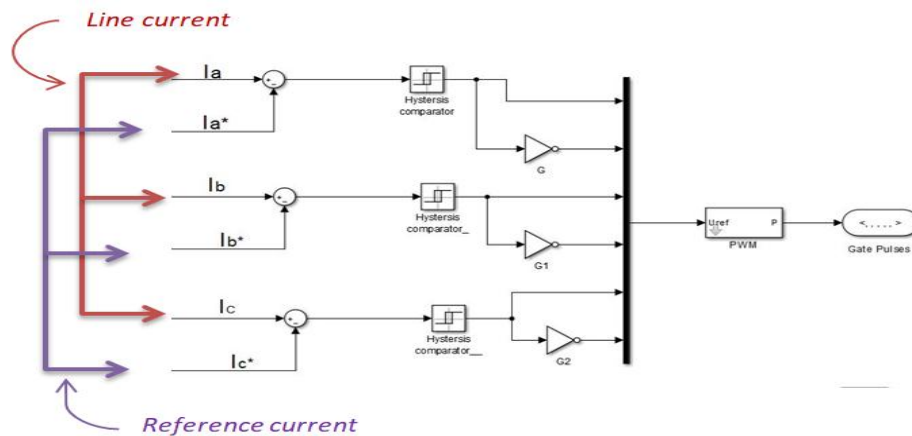

Fig-10 Equivalent circuit of Hysteresis control

3. SIMULATION RESULTS

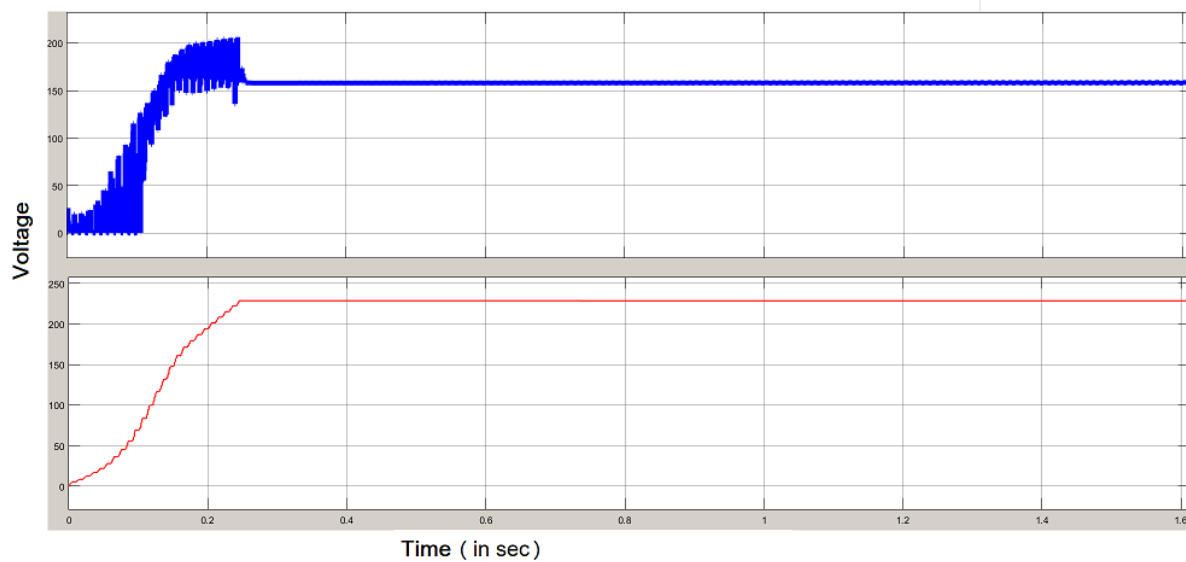

Fig-11. PV output voltage and power converter output voltage

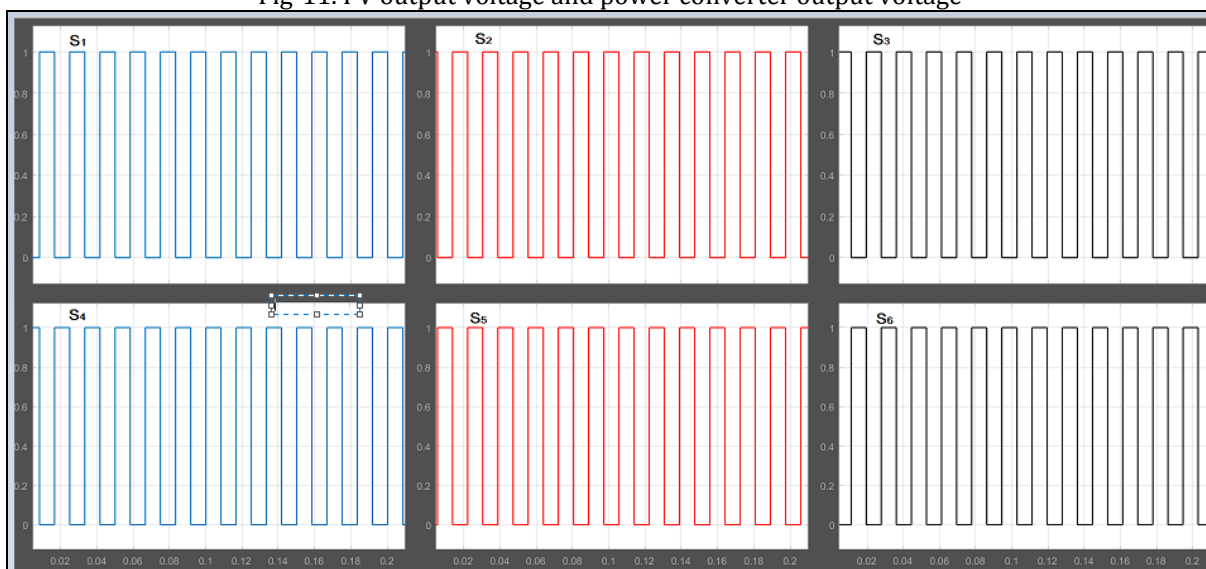

Fig 12. PWM generated by Hysteresis loop

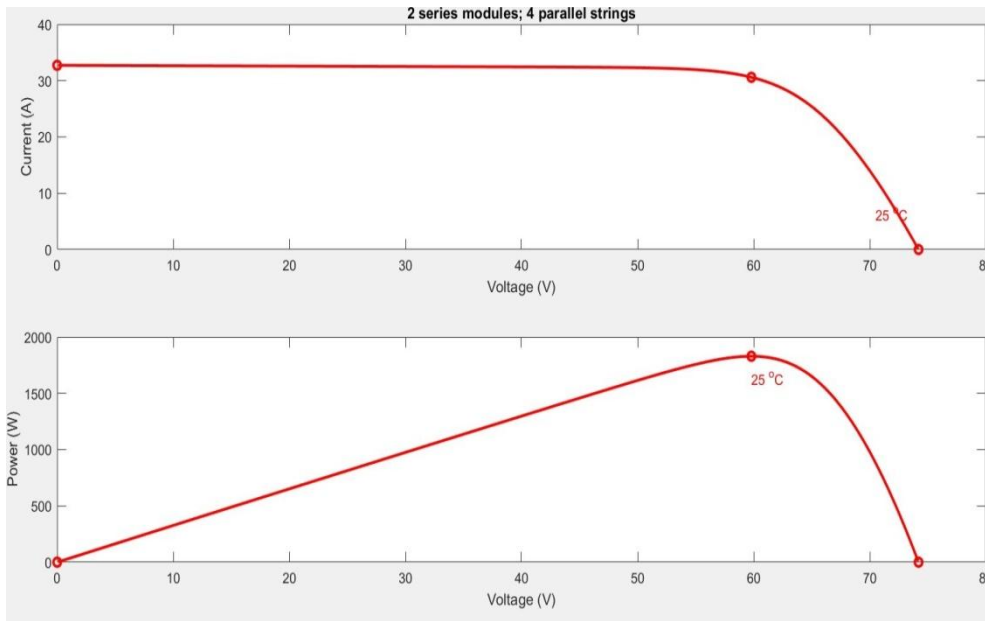

Fig-13.simulation result of PV of array with 25°C

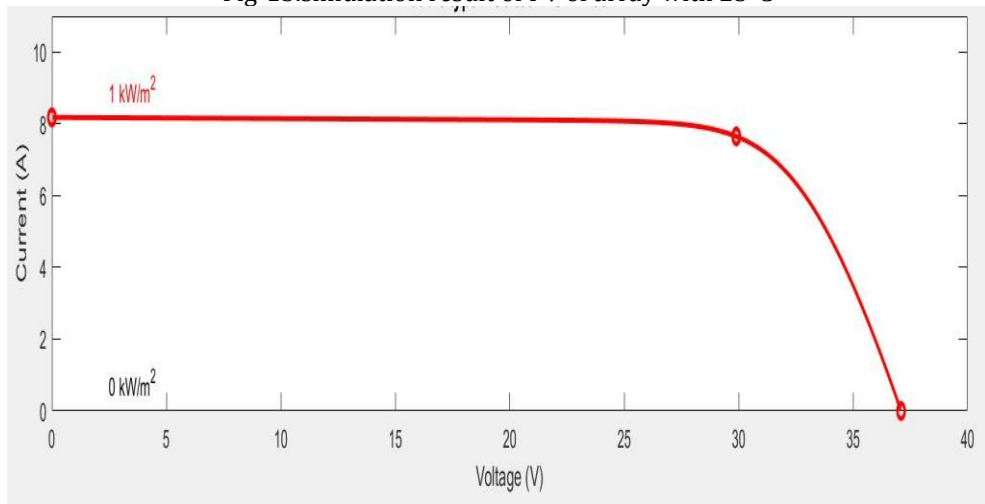

Fig-14.Simulation result of I-V characteristics of array with 1000w/m² irradiance

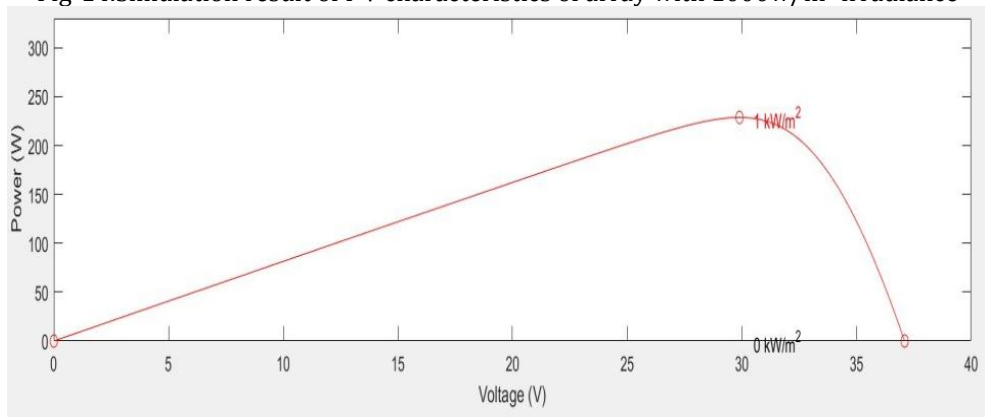

Fig-15. Simulation result of P-V characteristics of array with 1000w/m² irradiance

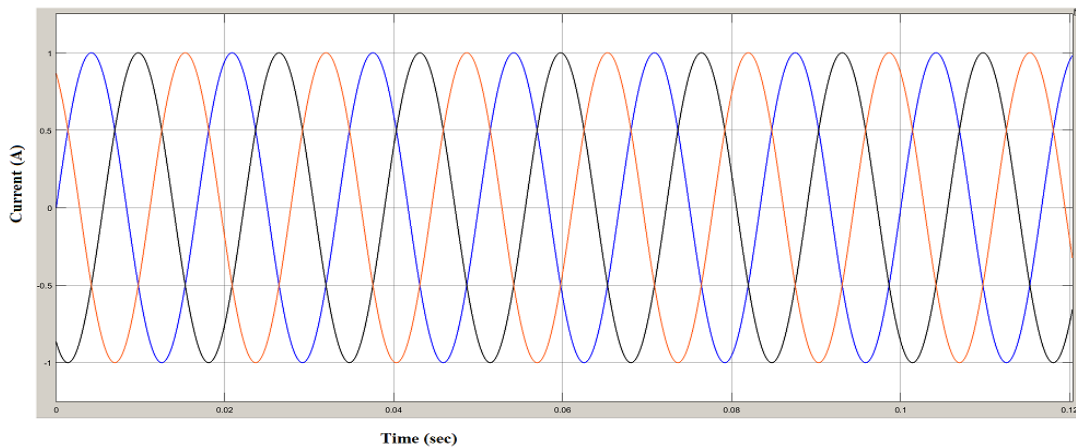

Fig-16. Reference current (i^*_{abc})

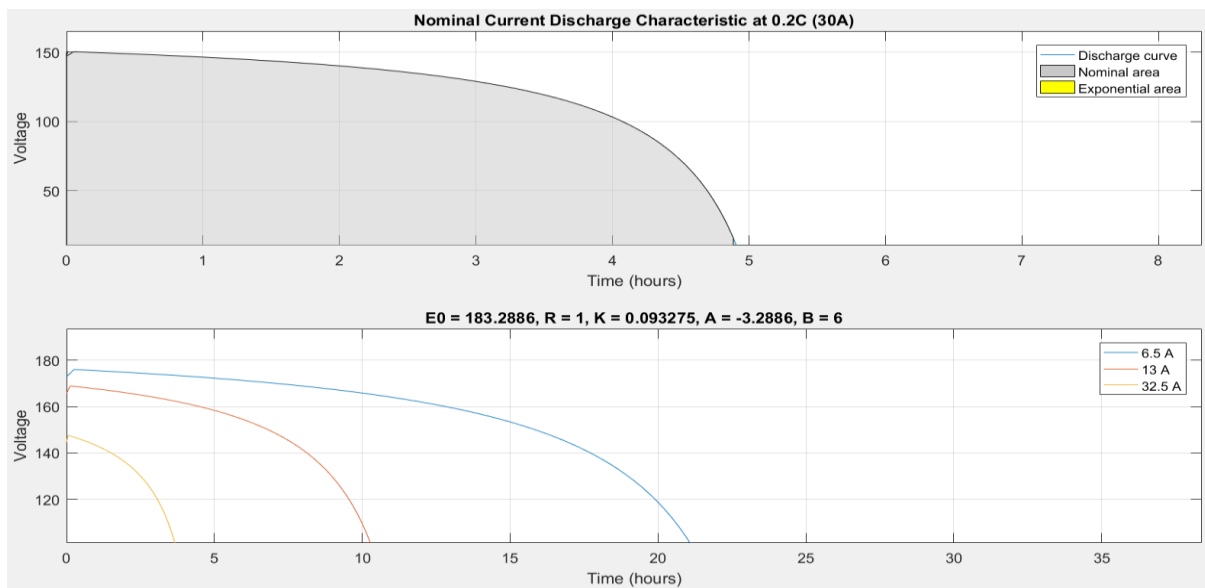

Fig-17. Battery current discharge characteristics-voltage vs time

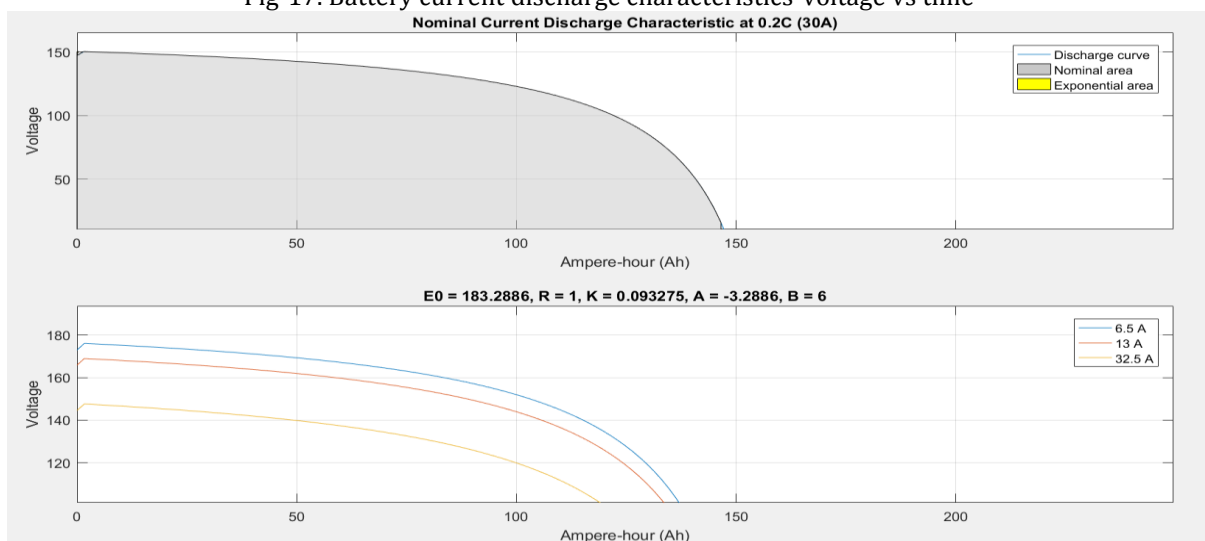

Fig-18 Battery current discharge characteristics - Voltage vs Ampere hour

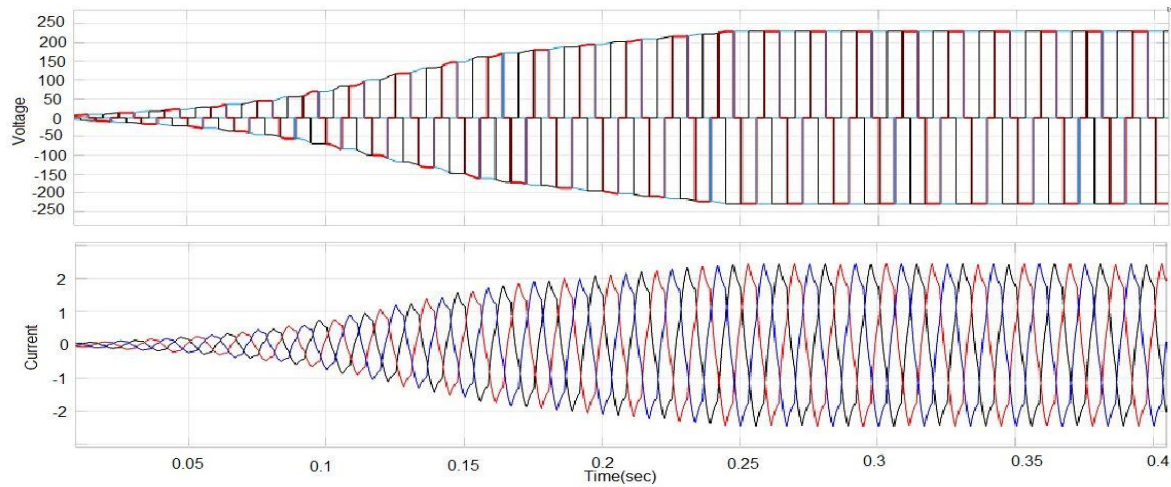

Fig-19. Inverter output voltage and current-PV connected mode

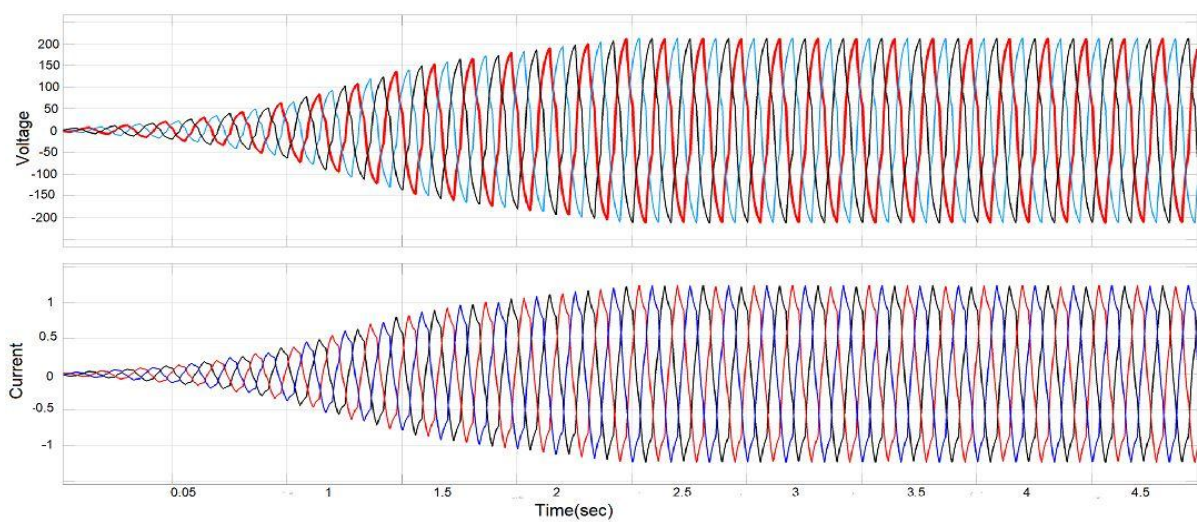

Fig-20. Inverter output voltage and current with LC filter-PV connected mode

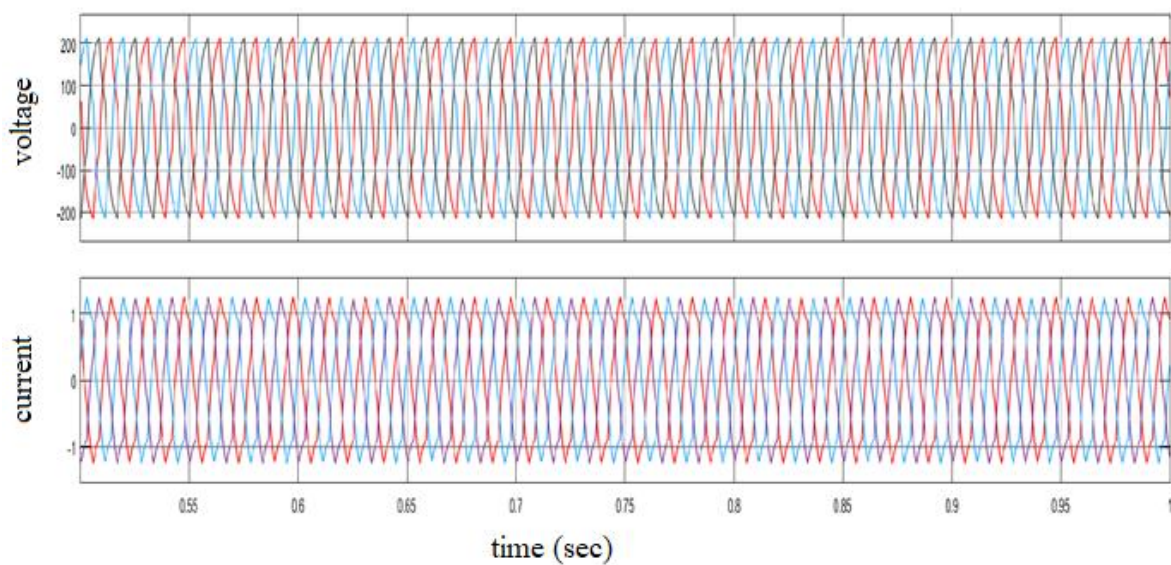

Fig-21. Inverter output voltage and current with LC filter-Battery connected mode

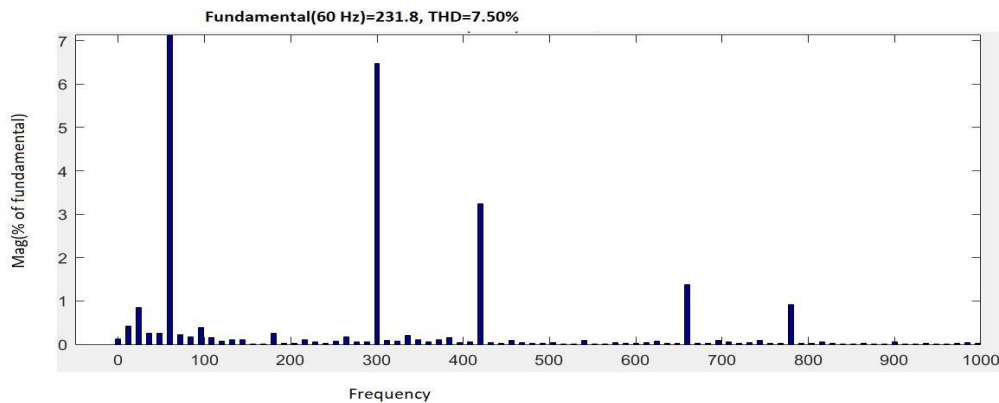

Fig-22 THD of inverter output voltage.

4. CONCLUSION

A hybrid system consisting of a photovoltaic (PV) array and rechargeable battery integrated to the distribution grid. The photovoltaic array, charge controller and the battery are connected to the dc-side of the VSI through the converter. The performance of load sharing and reducing demand with the distribution grid were analysed. MPPT is used for the system and optimized for the various irradiance and temperature. The VSI is applied for the hysteresis current control technique is applied and their performance also studied. The performance of system is analysed using Matlab/Simulink to verify the output efficiency of the proposed system.

References

- 1 V. Arangarajan, A. M. T. Oo, G. M. Shafiullah, M. Seyed mahmoudian and A. Stojcevski, "Optimum design and analysis study of Stand-alone residential solar PV Microgrid," 2014 Australasian Universities Power Engineering Conference (AUPEC), Perth, WA, 2014, pp. 1-7. doi: 10.1109/AUPEC.2014.6966522
- 2 Ahmad Alzahrani, Mehdi Ferdowsi, Pourya Shamsi, Cihan H. Dagli, Modelling and Simulation of Microgrid , Procedia Computer Science, Volume 114,2017, Pages 392-400, ISSN 1877-0509, <https://doi.org/10.1016/j.procs.2017.09.053>.
- 3 K. T. Tan, P. L. So, Y. C. Chu and K. H. Kwan, "Modelling, control and simulation of a photovoltaic power system for grid-connected and stand-alone applications," 2010 Conference Proceedings IPEC, Singapore, 2010, pp. 608-613. doi: 10.1109/IPEC.2010.5697066
- 4 R. Lasseter et al., White Paper on Integration of Distributed Energy Resources – The CERTS Micro Grid Concept, California Energy Commission, Oct. 2003.
- 5 B. Kroposki, T. Basso and R. DeBlasio, "Microgrid standards and technologies," 2008 IEEE Power and Energy Society General Meeting - Conversion and Delivery of Electrical Energy in the 21st Century, Pittsburgh, PA, 2008, pp. -4. doi: 10.1109/PES.2008.4596703
- 6 Weidong Xiao, W. G. Dunford and A. Capel, "A novel modeling method for photovoltaic cells," 2004 IEEE 35th Annual Power Electronics Specialists Conference (IEEE Cat. No.04CH37551), 2004, pp.1950-1956 Vol.3. doi: 10.1109/PESC.2004.1355416
- 7 N. Pandiarajan and R. Muthu, "Mathematical modeling of photovoltaic module with Simulink," 2011 1st International Conference on Electrical Energy Systems, Newport Beach, CA, 2011, pp.258-263. doi: 10.1109/ICEES.2011.5725339
- 8 M. LokeshReddy, P.J.R. Pavan Kumar, S. Aneel Manik Chandra, T.Sudhakar Babu, N. Rajasekar, **Comparative study on charge controller techniques for solar PV system**, Energy Procedia, Volume 117, 2017, Pages 1070-1077, ISSN 1876-6102, <https://doi.org/10.1016/j.egypro.2017.05.230>.
- 9 M. Subashini and M. Ramaswamy, "A novel design of charge controller for a standalone solar photovoltaic system," 2016 3rd International Conference on Electrical Energy Systems (ICEES), Chennai, 2016, pp.237-243. doi: 10.1109/ICEES.2016.7510647
- 10 Arjai, A., Bhardwaj, A., Sandhibigraha, M 'Study of maximum power point tracking (MPPT) techniques in a solar photovoltaic array'. Thesis, Department of Electrical Engineering National Institute of Technology, Rourkela, Orissa, 2011, pp. 43-49
- 11 Rokonuzaman, Md & Khatun Mishu, Mahmuda & Haider, Mohammed Hossam & Shamimul Islam, Md. (2017). Design of a MPPT Solar Charge Controller in Matlab-Simulink GUI Environment.
- 12 A. Alzahrani, P. Shamsi and M. Ferdowsi, "Analysis and design of bipolar Dickson DC-DC converter," 2017 IEEE Power and

- Energy Conference at Illinois (PECI), Champaign, IL, 2017, pp. 1-6. doi: 10.1109/PECI.2017.7935733
- 13 Hojabri, Mojgan & Ahmad, Abu Zaharin & Toudeshki, Arash & Soheilrad, Soroush. (2012). An Overview on Current Control Techniques for Grid Connected Renewable Energy Systems.
- 14 Yahaya, Jabbar & Mansor, Muhamad. (2013). Current control loop of 3-phase grid-connected inverter. IOP Conference Series: Earth and Environmental Science. 16. 2069-. 10.1088/1755-1315/16/1/012069.
- 15 A. Nachiappan, K. Sundararajan and V. Malarselvam, "Current controlled voltage source inverter using Hysteresis controller and PI controller," 2012 International Conference on Power, Signals, Controls and Computation, Thrissur, Kerala, 2012, pp. 1-6. doi: 10.1109/EPSCICON.2012.6175247