

IoT based SCADA for Stress Relieving Furnace

Ramesh Nadagoudar¹, Shivaling I Mukanavar²

¹Ramesh Nadagoudar, Lecturer, GPT Athani, Dist Belagavi, Karnataka, India

²Shivaling I Mukanavar, Lecturer, GPT Belagavi, Karnataka, India

Abstract - Number of disasters happens in the industry are increased in great extent. These disasters are mostly triggered due to system failure or due to carelessness monitoring and controlling of the system. Such accidents become Hazardous for human life working with that environment. To avoid such accidents happened due to system error we have to control the system parameter automatically. The system presented in this paper gives better result for the monitoring and controlling of the industrial system parameter from anyplace, at any moment by using internet. To satisfy the requirement of industries, an automatic control system is designed based on "PLC and SCADA". This paper describes the enactment of stress relieving furnace is used to eliminate internal stresses that have gathered in the material. This PLC based stress relieving will be distant monitoring, and operator convenience. Programmable Logic Controller is executed in place of embedded system since PLC can simply resist the defective situation happened in industrial environmental conditions and simply preserve all the definite needs of the system. In the current work, the ladder programming is used for PLC. It is simple and user-friendly programming, i.e., modification in the program can do as per our requirements. "Supervisory Control and Data Acquisition" is also used to supervise and control the working of the stress relieving furnace.

Key Words: SCADA, PLC, RTD Temperature Transmitter, Stress relieving furnace.

1. INTRODUCTION

Automation has much more importance in industry because due to automation overall productivity is increases. Standard of the product is also increases due to automation. It also reduces manufacturing cost. There are another several reasons such as lack of availability of skilled person, lack of industrial training centers so that automation got importance. Most of the developed countries suffer from lack of human resources. Those persons who work for their industry from many years they are leaving the industry. Training sessions required for newly hired candidate because of non-experience. Because of more workload candidate may quit the industry. Skill is becoming important factor in developing country. They have more manpower but these peoples are not skilled. Hence automation is necessary.

Technologies are designed for the industrial automation concerned with the monitoring and controlling of the different tasks in the industry. The boilers have specific operating temperature range. If the boiler temperature goes beyond the margin level then there is chance of explosion of

the boiler which is dangerous. Hence boiler temperature controlling is very important. Also, other parameters like speed, torque, pressure, available light etc. must be monitor and control.

Nowadays people wants to have world in their fingerprints. So that usage of internet is increased in large number. IoT is trending technology which binds all the living or non-living things of the world using internet. IoT is large internet network which provides communication between the people and thing any moment, anyplace. The data which is provided by different sensor such as temp, speed, light, pressure etc. are monitor using a web page or android mobile app.

1.1 Related work

Supervisory control and data acquisition is a system consists of both software and hardware elements. It controls industrial processes locally or at remote locations to monitor, collect, and process real-time data.

Paper is to impart an abstract of the different communications technologies handy for application with SCADA system projects. All communication media are addressed with a short explanation along with the Merits and Demerits. Based on the specifications we can choose the best suitable communication technology. [1]

Paper is imparted the automation of the water storage & distribution for various requirements and control the level in the storage tank and monitoring the pH, conductivity, temperature. In uses the PLC of "ALLEN BRADLEY MICROLOGIX "1200 make. It consists of 24 digital inputs (DI) which receives 24V DC and provides 16 potential free outputs with 4 channel analogue input module is used to control the process. [2]

The paper imparts the Web-based remote access real-time laboratory data using SCADA control. A PLC executes the programs which control the operation of the system. SCADA system was implemented to monitor and control of the operation. The Web interface was developed using Visual Studio with ASP.NET, which provides students to access the lab data. [3]

In recent years the SCADA system made a huge development in the field of Process Control. A control of process from any remote location is not happening without SCADA nowadays. Also, having possibility of additional

features like security, visualization, controlling of process parameters paves the way for SCADA being a powerful tool for industrial applications. [4]

To satisfy the requirements of industries, an automation control system is developed based on PLC and SCADA. SCADA is used for the purpose to see the view of the full machine, display alarms, trends, reporting of the furnace in SQL server. By using this technique, it can be analyzed in terms of monitoring, controlling the furnace, efficiency, avoiding waste energy, accuracy, fault history industrial production and performance of the whole system. [5][6][7]

Number of disasters happens in the industry are increased in great extent. These disasters are mostly triggered due to system failure or due to carelessness monitoring and controlling of the system. Such accidents become Hazardous for human life working with that environment. To avoid such accidents happened due to system error we have to control the system parameter automatically. The system presented in this paper gives better result for the monitoring and controlling of the industrial system parameter from anyplace, at any moment by using internet. [8]

1.2 Methodology

The below shown block diagram demonstrates the proposed frame work. As shown in figure the system consists of PLC DVP12SE11T, RTD Temperature Transmitter, Stress relieving furnace, Router, Relay Board, SCADA software.

The temperature is measure with the help of the RTD temperature transmitter. The RTD sends the current signal of range 4-20mA equivalent to the temperature range of 0°C to 150°C to analog module in the PLC. The analog module converts the analog current into digital signals with the resolution: 5µA, ±4000 (13bits). The digital signals are then applied to the PLC for temperature control operation. The control operation is written in ladder logic programming is executed in the PLC. The PLC is remotely controlled through SCADA via Router using WiFi. The PLC is communicated to router using ethernet TCP/IP protocol.

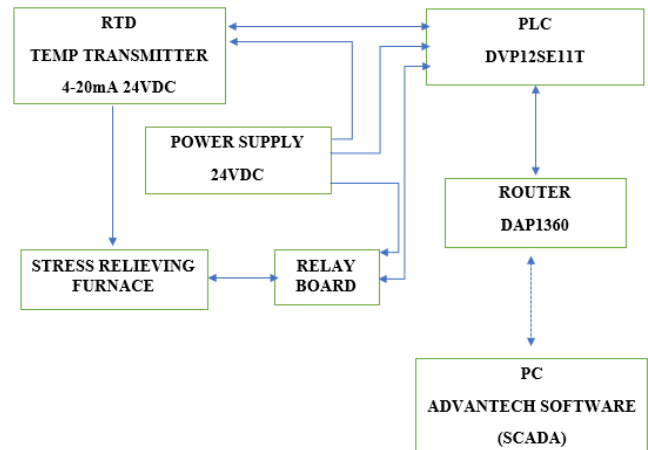

Figure 1: Block Diagram

A. Hardware used

1. DVP12SE11T PLC: This is most complete network type slim PLC in the industry. It consists of 8 digital inputs and 4 digital outputs. Built in mini USB, Ethernet and 2 RS-485 ports.

2. RTD Temperature Transmitter

4-20mA 24vDC PT100 Temperature transmitter is used. PT100 is the most common type has a resistance of 100 ohms at 0 °C. The range of the temperature is measured from 0°C to 150°C.

3. Stress relieving furnace

Stress relieving furnace is developed to minimize residual stresses in the structure thereby reducing the risk of dimensional changes during further manufacturing or final use of the component.

4. Relay Board

Single switch over 4 channel 24vDC relay board is used to control the stress relieving furnace through PLC using SCADA control.

5. Router

The DAP-1360 offers seven modes of operation, namely Access Point, Wireless Client, Bridge, Bridge with AP, Repeater, WISP Client Router, and WISP Repeater (Range Extender) Mode.

B Software Used

1. WPLSoft V2.45: In this project the codes are written in LADDER LOGIC. Ladder logic has evolved into a programming language that represents a program by a graphical diagram based on the circuit diagrams of relay logic hardware. Ladder

logic is used to develop software for programmable logic controllers used in industrial control applications

2. Advantech Web Access software: Advantech Web Access, as the core of Advantech’s IoT solution, provides users with a cross-platform, cross-browser data access experience and a user interface based on HTML5 technology. With Web Access, users can build an information management platform and improve the effectiveness of vertical markets’ development and management.

B. Flow Diagram

The figure shows the flow diagram.

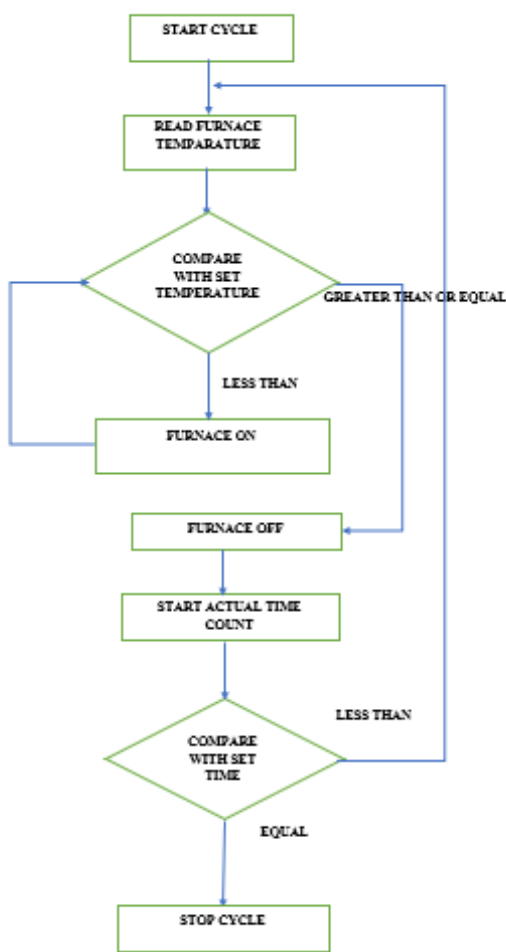

Figure 2: Flow Diagram

Initially set the SET Temperature and SET Time.

Step1: CYCLE STARTS

Step2: Read the temperature from the RTD temperature transmitter through PLC scan operation and monitored on the SCADA screen and update the temperature on every PLC scan.

Step3: If the furnace temperature is less than set temperature and turn ON the furnace to increase

temperature up to set temperature for the stress relieving operation. Else the furnace temperature is equal to the set temperature then turn OFF furnace.

Step4: Start counting the actual time up to set time. For every time count repeat Step3 and Step4.

Step5: When the actual time is equal to set time then the CYCLE END means completion of complete operation.

Step6: Repeat Step 1 to 5 for another operation for different values of SET Temperature and SET Time.

2. Results

The SCADA screen indicates the SET Temperature, FURNACE Temperature, SET Time, ACTUAL Time, CYCLE Start, CYCLE Stop, FURNACE ON/OFF, BACK, TREND, NEXT.

The operation starts with setting the SET TEMPERATURE and SET TIME parameter and enabling the CYCLE ON button in the SCADA screen. Then the furnace temperature is controlled by the PLC according the program stored in the PLC memory. The control operation is the displayed in the SCADA screen. The operation will end with enabling the CYCLE STOP button.

The control operation can also see in the schematic window and real time trending graph indicates the furnace temperature variation with respect to the time.

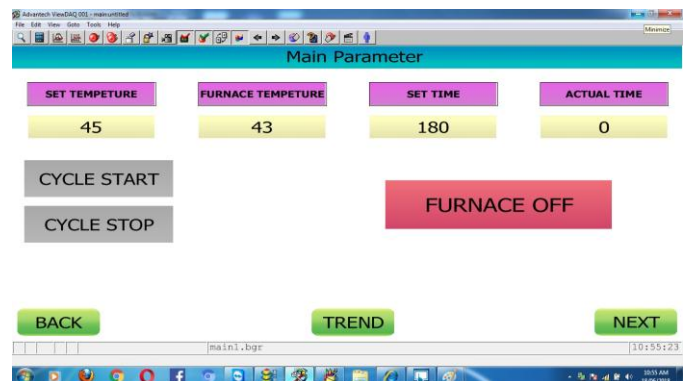

Figure 3: SCADA operation page

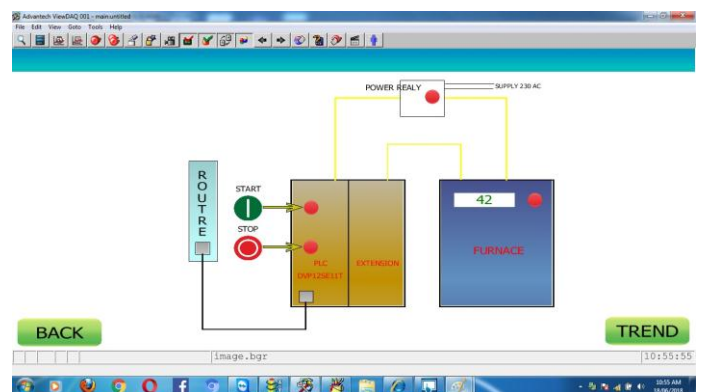

Figure 4: SCADA circuit schematic



Figure 5: Trending graph

The trending graph indicates the temperature with respect to time.

3. CONCLUSION AND FUTURE SCOPE

Thus, here built a system for monitoring and controlling of industrial furnace temperature for stress relieving purpose by using new emerging technology of internet of things. This system gives efficient solution than other systems. In this system we gather the data from the sensor and made it available to the user from remote location at any moment. Hence it will become low cost, high efficient embedded system.

The system performance and features can be further improved with the help of better sensors and improved SCADA software developments.

REFERENCES

- 1] Communications Technology Guidelines for EMS/SCADA Systems, Donald J. Marihart, Fellow, IEEE, IEEE TRANSACTIONS ON POWER DELIVERY, VOL. 16, NO. 2, APRIL 2001.
- 2] Water Storage and Distribution System for Pharmaceuticals using PLC and SCADA, V Rajeswari., Dr L Padma Suresh, G Narayanamma, 2013 International Conference on Circuits, Power and Computing Technologies [ICCPCT-2013].
- 3] A Web-Based Remote Access Laboratory Using SCADA, Zafer Aydogmus, Member, IEEE, and Omur Aydogmus, Student Member, IEEE, IEEE TRANSACTIONS ON EDUCATION, VOL. 52, NO. 1, FEBRUARY 2009.
- 4] ZigBee Based Design of Low Cost SCADA System for Industrial Process Applications, R. Immanuel Rajkumar, T. Jerry Alexander, Ponni Devi, 2016 IEEE International Conference on Computational Intelligence and Computing Research.
- 5] Monitoring and Controlling of Continue Furnace Line using PLC and SCADA, Amandeep Kaur, Dipti Bansal, A review" IJMDEBM, Vol.4, Issue 2, June 2016.

[6] Steam Turbine Lube Oil System Protections using SCADA & PLC, Astha Nagar, Prof. Sandip Mehta, International Conference on Intelligent Computing and Control Systems ICICCS 2017

[7] Designing Sealing Process for LPG Cylinders and its Simulation using SCADA. Mr. Chaitanya U. Prabhu Gaunker, Mr. Devendra Sutar, Proceedings of the IEEE 2017 International Conference on Computing Methodologies and Communication, (ICCMC).

[8] IOT Based Industrial SCADA System, Prof. S. S. Shah, Sanket Raut, Dipak Jagadale, Amar Khatmode, Hajrat Patil, International Research Journal of Engineering and Technology (IRJET), Volume: 04 Issue: 04 | Apr -2017.

BIOGRAPHIES



Ramesh Nadagoudar

M.Tech(VLSI & Embedded systems)
Lecturer in E&C Dept.
Government Polytechnic Athani,
Dist: Belagavi, Karnataka, India



Shivaling I Mukanavar

M.Sc(Engg) By Research
Lecturer in Mechanical Engg Dept,
Government Polytechnic Belagavi.
Karnataka, India.