

REVIEW PAPER ON HYDROGEN: THE FUEL OF FUTURE

Vatsal Panthri¹, Ankit Singh, Sagar Jaggi³, Divyanshu Jaggi⁴

^{1,2,3,4}Student, Dept. of Mechanical and Automation Engineering, ADGITM, Delhi, India

Abstract - Energy requirement has significantly increased in the past few decades and to fulfill these requirements extensive use of fossil fuel is required which in turn has been a concern the supply of these fossil fuel scarce. Hence there has been a surge in the number of researches that are going on to find the best suitable alternative to eliminate the use of fossil fuel. Hydrogen being one of the alternatives has been the advantage of being a cleaner fuel as compared to petroleum drive fuels. But one of the major issue related with the use of hydrogen is that it is not easy to store hydrogen as it requires skilled operations and expensive machining types of equipment also if we take into account other factors such as transportation cost, production cost, etc. and compare them to the advantage of hydrogen being an emission-free transportation fuel we need to find answers to the fact that whether hydrogen can be the fuel of future?

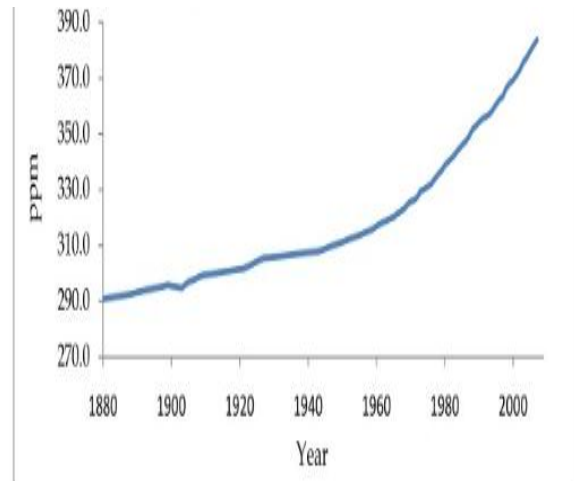

Figure 1; CO₂ Concentration Since 1880[1]

Key Words: Hydrogen, Alternative Fuel, Energy, Fuel Cell, PEM.

1. INTRODUCTION

As we know climate change has been a serious issue it is becoming increasingly evident to much of the population. One of the reasons behind this climate change is the rising level of carbon dioxide(CO₂) and other pollutants emitted during the various method of production of energy which depends upon fossil fuels as a source it has also led to a phenomenon known as Global Warming. The main aim of this project is to find data that can suggest whether there is a suitable alternative that can be used to fossil fuel being the primary source to produce energy [1]. Hydrogen has been found out to be a major reader in the search of alternative as it can be an energy carrier in the Internal Combustion Engine and the level of emission is significantly less when combustion with oxygen. The main concern behind labeling hydrogen as the fuel of the future is that the big production and storage have been a difficult task and unless until now there has been no significant improvement in this field which has raised concern about whether the hydrogen can replace fossil fuels completely [2]. At present, there are three major problems of using hydrogen. First, the new generation of the hydrogen storage system and development of infrastructure according to requirement. Secondly, the reduction in the cost of the hydrogen-based system. Lastly, the cost of efficient and sustainable production of hydrogen must be reduced.

One of the important features of hydrogen as a fuel is its by-product upon combustion. In an ideal scenario, it will only produce water as shown in the equation: $2H_2 + O_2 \rightarrow 2H_2O$. This equation is true if the combustion takes place in ideal conditions. But practical conditions differ as there is nitrogen (78%) present in the air which is used for combustion. This leads to the realistic equation of combustion: $H_2 + O_2 + N_2 \rightarrow H_2O + NO_x + N_2$, so in reality, there is also emission of nitrogen oxide and nitrogen. But the emission of oxides of nitrogen can be controlled by using a catalytic converter. This type of converter will only need is platinum-based which is required for reduction of nitrogen: $NO_x \rightarrow N_x + O_x$. Which will reduce the overall cost of the catalyst. But this is still better than the carbon emission of traditional engines which is way more harmful.

2. ADVANTAGES AND DISADVANTAGES OF HYDROGEN AS A TRANSPORTATION FUEL

Hydrogen as a fuel has many advantages over any conventional fuel present today. Firstly, it has a very high yield of energy (122Kj/g). Yield energy generally refers to the amount of energy harvested from the energy source. Hydrogen can easily be produced from many primary sources of energy that are present today, as the steam reforming of methane gas that is the most prominent method of hydrogen production today. As compared to other fuels hydrogen has a wide range of flammability i.e around 4%to 74% in air and 4% to 94%in oxygen.

Hydrogen has an excellent air to fuel ratio ranges from 34:1 to 180:1, which means we can run a vehicle on a very lean

mixture of fuel. This also helps in reducing the overall nitrogen emission of the vehicle [4]. It also has a high diffusivity when compared to the other fuels. This results in complete and predictable combustion. Another big advantage of hydrogen having a high diffusivity is that if there is a leak somewhere in the fuel system, the hydrogen will quickly disperse into the atmosphere because of its high diffusivity rate. This reduces the chance of any accident that might be caused because of leaking fuel in the vehicle. Any fuel which is used should have a good abundance in nature and so does hydrogen which indirectly proves it to be the fuel of the future as it would be easily available everywhere. Every substance has its pros and cons so does hydrogen. They include- its low density that results in the requirement of large storage containers. it is not found in its original state in nature, which results in increased cost of its production. The main problem associated with hydrogen is its storage and transport. There is a lack of containers and suitable materials that can store hydrogen safely and at a reasonable price.

Under the optimal conditions for combustion (29% of hydrogen to air ratio), we require much less energy to initiate combustion as compared to other fuels present today (using a sparkplug) as shown in fig.3. From the figure, we can see that the energy required for hydrogen combustion (0.02mJ) is significantly lower than any other fuel. So, it is very easy to ignite the mixture in the combustion chamber. Whereas in a low concentration of hydrogen, the energy required to start combustion is comparable to other fuels.

3. VARIOUS METHODS TO PRODUCE HYDROGEN

There are many different methods to produce hydrogen used across the world. Some of them are discussed below-

Steam Reforming of Methane Gas

This method is widely used today because of its high efficiency (65-75%) and its low cost. It is carried out in the presence of nickel as a catalyst and the reaction is as follows:

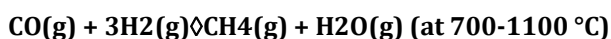

But the disadvantage of this method is that it produces carbon dioxide which pollutes the environment and it is a non-renewable source.

Electrolysis of Hydrogen

Another method that is highly regarded as the future for producing hydrogen but remains on sidelines today because of its relatively higher cost is electrolysis. The reaction associated is as follows-

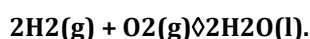

It is a relatively easier method of producing hydrogen and is currently under research for a reduction in overall cost. The only disadvantage of this method is that external current

input is required which makes this process costly and thus is not highly recommended.

Gasification

Gasification is a process that converts coal into gaseous mixture of hydrogen, carbon monoxide, carbon dioxide, and methane. The reaction is as follows: -



This coal is used under high pressure and temperature to produce syngas, which is further used to produce hydrogen. This method is very cheap and used for mass production of hydrogen. But its limitations are the emission of carbon dioxide and monoxide as its very harmful by-products.

Solar hydrogen system

Another alternate to producing hydrogen which is developing as we speak is a solar-hydrogen system. In this, we use the current mode with the help of solar energy and pass it through the water. This produces hydrogen and oxygen as its by-product. It is an efficient method of producing hydrogen and has much potential in the future. As of now, it is used in a limited number of areas because of its high cost.

4. STORAGE METHODS FOR HYDROGEN

Other than the production of hydrogen one of the major highlights, being its storage and transportation because of its low density

Some of the forms in which the hydrogen is stored are as follows: -

Compressed Form

Compressing any gas generally allow more compact storage. Hydrogen is generally stored at high pressure up to 2000 pounds per square inch .the major advantage is that this form is more reliable, its helps in increasing the storage time and thus it is easy to use, however, large capital investment is required and the excessive heat may rupture the container

Liquid Form

Liquefied hydrogen is denser than gaseous hydrogen and thus has a higher energy content on a per unit volume basis. To convert into a liquid, it is cooled to -235. In liquid form it has a high density at low pressure, however, it has a high cost and if there is a sudden escape of the gas it may cause a fire. Hence to convert a liquid a low temperature is needed which is difficult to achieve

Metal Hybrid

Hydrogen can also be stored on the surface of the material or with the structure. Very broadly a hybrid is a chemical

compound containing hydrogen and at least one other element. Metal hybrids can store hydrogen via absorption. This form is considered as one of the safest forms, it has high volume efficiencies. The only disadvantage of using this form is that it is costly and large trunks are required to store it

5. DISCUSSION

As discussed earlier there are several advantages and disadvantages associated with the use of hydrogen as a fuel. There are mainly two methods by which hydrogen can be used as a replacement for petroleum-based energy sources, firstly hydrogen can directly be used as a primary fuel in the internal combustion engine where the combustion of hydrogen takes place in the presence of oxygen which leads to the development of physical movements of parts of the engine. The main disadvantage of the method is that its efficiency is small around 20% [4].

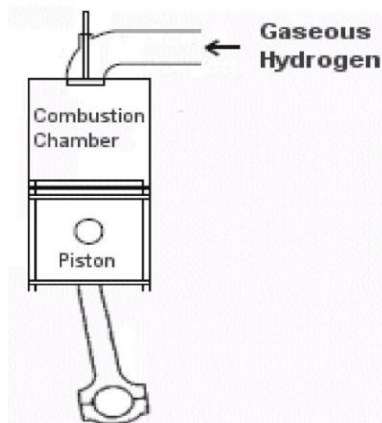

Figure 2 : Hydrogen-engine [5]

Hence another alternative method which includes the use of PEM fuel cells which produces an electric current using hydrogen and oxygen. In a polymer electrolyte membrane fuel cell hydrogen is split into ions by the use of platinum catalyst at the anode. The fuel cells are arranged in a defined order which helps to provide enough electric power that can be adequate for the operation of the vehicle. The advantage of this method overuse of hydrogen as a primary fuel in the internal combustion engine is that the efficiency of this method is around 45-60%.

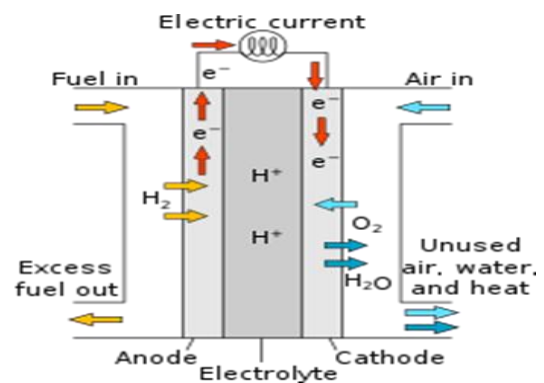

Figure 3 : PEM Fuel Cell [6]

Therefore, the use of hydrogen can be one of the alternatives that can replace fossil fuels as a primary source of energy. As we know hydrogen is the most abundant element on our planet, but hydrogen does not exist freely, it requires various complex processes to produce hydrogen which can be used as fuel. The main reason behind the search for alternative fuel is to reduce carbon dioxide emissions as a problem like global warming is one of the major concerns of the entire world. As discussed earlier the major issues related to the use of hydrogen are its storage and transportation facilities. Furthermore, the infrastructure cost for the hydrogen economy is high as transportation of hydrogen can be done only through a specialized method that requires the use of an underground pipe system and this system can be economical when the demand growth is enough. Hence the conclusion that can be drawn from this paper is that hydrogen can be the fuel of the future but for the time being the economic impact of the use of hydrogen as a fuel is not acceptable, but a further modification in the infrastructure like building a proper pipeline system can help to reduce the transportation cost and clear the path for hydrogen to replace fossil fuels.

REFERENCES

- 1) Rachel Chamousis, "HYDROGEN: FUEL OF THE FUTURE,"
- 2) Ivan Blagojevic, Sasa Mitic, "HYDROGEN AS A VEHICLE FUEL," International Congress Motor Vehicles and Motors 2018, Kragujevac, Serbia.
- 3) A.H. Awad, T. N. Veziroglu, "HYDROGEN VERSUS SYNTHETIC FOSSIL FUELS," Pergamon Press Ltd, International Association for Hydrogen Energy.
- 4) A.J. Appleby, "FUEL CELLS AND HYDROGEN FUEL," Pergamon Press Ltd, International Association for Hydrogen Energy.
- 5) <http://hydroxene.net/images/hydrogen-engine.gif> (Nov 12, 2008)
- 6) https://en.m.wikipedia.org/wiki/Proton-exchange_membrane_fuel_cell