

# Design of EV Charger with Cuk Converter to Improve Power Quality

Peer Mohammad Kolakar<sup>1</sup>, Dr. Adinath Jain<sup>2</sup>

<sup>1</sup>PG student, Department of Electrical and Electronics Engineering, RV college of Engineering, Bengaluru

<sup>2</sup>Assistant Professor, Department of Electrical and Electronics Engineering, RV college of Engineering, Bengaluru

\*\*\*

**Abstract** - A Cuk converter based EV (Electric Vehicle) battery charger is designed and developed in this work. It provides low cost and high-power density-based charging solution for EV. This charger incorporates less number of devices operating over one switching cycle, which reduces the additional conduction loss incurred by a diode bridge rectifier of conventional charger and hence, improves the charger efficiency. During constant current and constant voltage regions, the commands for battery charging, are synchronized by a flyback converter. The proposed charger draws a sinusoidal current from AC mains along with the total harmonic distortion (THD) in supply current is reduced to the limits as per the IEC 61000-3-2 standard. The proposed charger is designed in discontinuous conduction mode (DCM) with the desirable inherent zero current switching operation and low reverse recovery losses in circuit diodes. The proposed charger is tested to demonstrate the improved power quality. Test results confirm the improved performance of the proposed charger.

**Key Words:** Bridgeless Cuk converter, Battery charger, Power factor correction, Flyback converter, DCM, Power quality

## 1. INTRODUCTION

In recent times, for the sustainable development of the modern transportation sector, battery powered electric vehicles (BEVs) are dominating over the conventional gasoline powered vehicles. The transportation electrification is the most feasible way to establish a clean energy-based vehicle market since the power source used to charge these batteries, is obtained from the electricity. To facilitate the battery charging, an AC-DC converter based on board or off board charger is the significant supporting equipment of the electric vehicle (EV) [1]. However, the conventional battery charger for EV, has the drawbacks of poor performance in terms of power quality and efficiency due to nonlinear behavior of input diode bridge rectifier, used at input AC-DC conversion stage. The battery rating and the specifications of EV under test, are given in Table-I. It is obvious from these recorded waveforms that the performance of the DBR fed charger does not comply with the international regulations such as the IEC 6100-3-2 standard [2]. Therefore, to improve the input power quality indices to the recommended standard, the power factor correction converters (PFC), are replacing the AC-DC conversion stage of the conventional charger.

However, the DBR (Diode Bridge Rectifier) fed PFC converter affects the charger efficiency due to significant conduction loss incurred by the four input diodes. In this context, various single phase unidirectional and bidirectional improved power quality-based converters have been analyzed in [3]. The buck and boost [4] converters are not the appropriate choices for PFC in EV charger due to the poor current shaping feature and duty cycle limitations, respectively. However, the bridgeless buck-boost converter [5] offers the most attractive solution for PFC in EV chargers as they can both buck and boost the input voltage so wide range of duty cycle variation is available to control the charger output voltage. The different buck-boost configurations-based converters such as Cuk and SEPIC converters are described and analyzed in [6]. Nevertheless both, Cuk and SEPIC converters have low input current ripple and wide duty cycle variation is available for both the converters, still the SEPIC converter has the limitation of discontinuous output current, unlike Cuk converter. Therefore, Cuk converter provides more feasible charging characteristics to the battery due to low ripple in battery current.

Fardoun et al [7] have shown three topologies of bridgeless Cuk converter with advantages such as lower input current, less EMI and easy implementation. However, all these topologies use large number of devices such as 2 output capacitors in topology-2, which is also having the drawback of floating neutral due to arrangement of switches for independent half of supply voltage. Moreover, topology- 2, has the disadvantage of floating terminal for load between the two capacitors at output. Topologies-1 and 3 suffer from the problem of circulating losses in the two halves of supply voltage due to common intermediate capacitor terminal. To provide the in-built current shaping feature to the bridgeless PFC converter, average current mode control and voltage follower mode control, are used. The PWM switching depends upon the selection of converter mode of operation, i.e continuous conduction mode and discontinuous conduction mode.

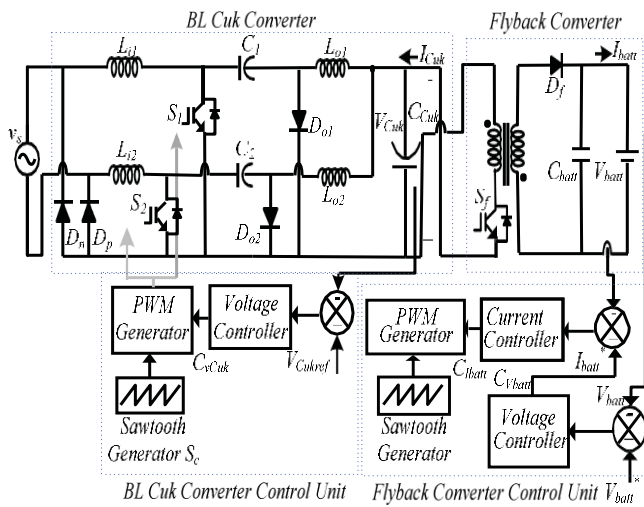

Fig. 1 Proposed BL Cuk Converter based EV Charger Configuration

To obtain a cost-effective charging solution, the converter is selected to operate in DCM mode and voltage feedback based PWM control is used owing to the use of single sensor at output. To avoid the pulse bursting phenomenon in DCM operation, the constant on-time control based PWM switching is seldom used. However, the variable duty cycle control based PWM switching is used in proposed converter, due to the excellent current shaping feature [8] and retaining the benefits of DCM operation such as, zero current switching and no reverse recovery loss in diodes. The flyback converter is also designed to operate in DCM mode [9] with cascaded dual loop controller, which controls the battery charging commands during CC (Constant Current) and CV (Constant Voltage) charging regions.

The DC link voltage of Cuk converter is controlled at 300V. A prototype is developed and the improved performance of proposed EV charger is demonstrated for steady state and for fluctuations in AC voltages to charge a 48V, 100Ah lead acid battery of EV.

## 2. CONFIGURATION OF PROPOSED CHARGER

The configuration of proposed power quality improved EV charger is shown in Fig.2 which is composed of a bridgeless (BL) Cuk power factor correction (PFC) converter and a flyback converter. The proposed PFC Cuk converter operates for positive half cycle with switch  $S_1$ , input inductor  $L_{i1}$ , output diode  $D_{o1}$  and output inductor  $L_{o1}$ . Similar switching pattern is followed for next half cycle with the switch  $S_2$ , input inductor  $L_{i2}$ , output diode  $D_{o2}$  and inductor  $L_{o2}$ . The DC link voltage of PFC Cuk converter is maintained constant using single loop voltage feedback control, which reduces the charger cost due to use of single voltage sensor. The flyback converter controls the battery current for charging in constant current and constant

voltage regions using cascaded proportional integral (PI) controller.

## 3. OPERATING PRINCIPLE

The operating principle of the proposed EV charger is given in this section. Due to symmetry in waveforms, only positive half cycle of BL converter is taken into consideration, as depicted in Fig 3(a)-(c)

### A. Operation of BL Cuk Converter

As shown in Figs. 3(a)-(c), the first mode of positive half cycle operation (P-I) begins at  $t_1$ , when gate pulse to the switch  $S_1$  is applied. The current through the input inductor  $L_{i1}$  rises linearly with the slope shown in Fig 2. The intermediate capacitor  $C_1$  starts discharging through the switch  $S_1$  and output inductor,  $L_{o1}$ , as shown in Fig3 (a).

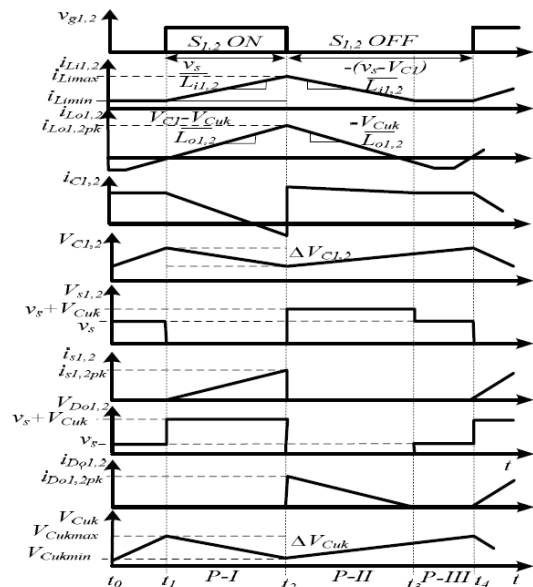
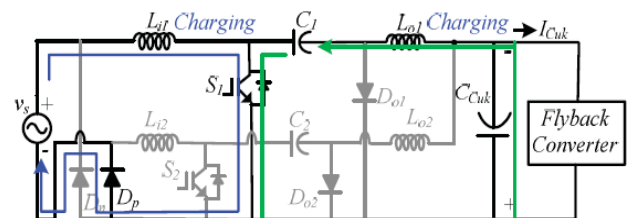

Fig. 2 Associated switching behaviour of the different components over one switching cycle



(a)

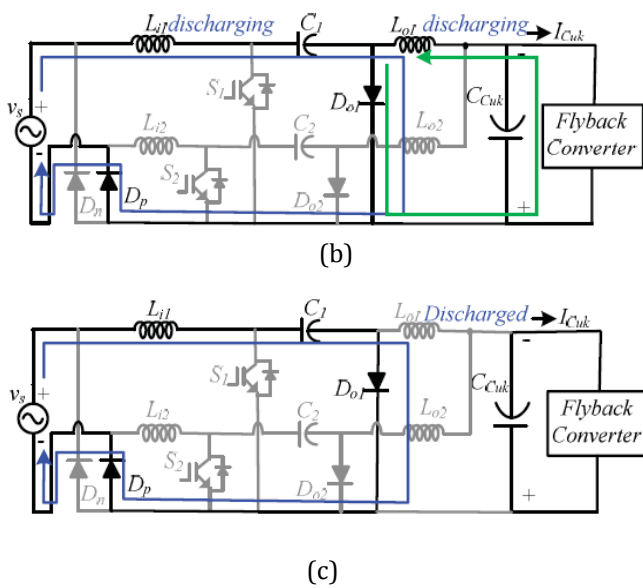

Fig. 3 Circuit Operation of BL PFC Cuk Converter fed EV Charger (a) Mode P-I (b) Mode P-II (c) Mode P-III

Mode P-II starts when the polarity of the capacitor  $C_1$  reverses as the gate pulses to the switch are made OFF at the instant  $t_2$ . The input inductor  $L_{i1}$  starts releasing the stored energy through the capacitor  $C_1$ , and the diode  $D_{o1}$  of the converter, as shown in Fig. 4 (b). The output inductor discharges through the output diode and DC link capacitor  $C_{Cuk}$ . Now, at the instant  $t_3$ , Mode P-III begins when the current through the output inductor becomes zero the output inductor  $L_{o1}$  is discharged completely, as obvious in Fig. 4 (c). During this period, the Cuk converter operates in DCM mode and the flyback converter at the output of PFC Cuk converter, gets the required power from the DC-link Capacitor  $C_{cuk}$ .

**B. Operation of Flyback Converter**

The operation of flyback converter is analyzed based on DCM of magnetizing inductance of the high frequency transformer (HFT). The current through the magnetizing inductance  $L_{mf}$  rises linearly and it stores the energy when the flyback switch  $S_f$  is made ON. The output diode  $D_f$  is reverse biased due to the dot convention of HFT, during this instant. The output power is delivered to the battery when the polarity of the HFT is reversed during switch OFF instant as the output diode  $D_f$  becomes forward biased. However, when the magnetizing inductance is discharged fully, during each switching cycle, the output capacitor  $C_{batt}$  provides the required battery charging current in CC mode.

**4. DESIGN OF EV CHARGER**

The proposed EV charger is designed in DCM mode using the design expressions given in this section. The

symbols and constants used in the calculation denote same quantities as shown in Fig.1. Using the output voltage  $V_{Cuk}$  and peak input voltage,  $V_{spk}$  of PFC Cuk converter, the voltage conversion ratio, is given as,

$$M = \frac{V_{Cuk}}{V_{spk}} = \frac{300}{220\sqrt{2}} = 0.964$$

$$K_e = \frac{I}{2(M+n)^2} = \frac{I}{2(0.964+1)^2} = 0.1296$$

Where  $K_e$  denotes conduction parameter of PFC converter

n is 1 for non-isolated cuk converter

Table 1 Design of Proposed BL PFC Converter Based Charger

Component Parameter	Design Expression	Estimated Value	Selected Value
Input inductor	$L_{i1,2} = \frac{V_s \times D_{Cuk}}{\gamma I_1 \times f_{sc}} = \frac{220 \times 0.384}{0.4 \times (850 / 311) \times 20000}$	3.86mH	4mH
Output Inductor	$L_{o1,2} = \frac{L_f \times L_{eq}}{L_f - L_{eq}} = \frac{4 \times 211}{4 - 211}$	0.222mH	0.15mH
Intermediate capacitor	$C_{1,2} = \frac{I}{\omega_s^2 (L_{i1,2} + L_{o1,2})} = \frac{I}{(2 \times \pi \times 1500)^2 (4 + 0.15) mH}$	2.712 $\mu$ F	3 $\mu$ F
DC link Capacitor	$C_{Cuk} = \frac{I_{cuk}}{2 \omega W_{cuk}} = \frac{(850 / 300)}{314 \times 0.01 \times 300}$	3mF	4.7mF
HFT Magnetising Inductance $L_{mf}$	$L_f = \frac{V_{cuk} D_{fb}}{I_{mf} f_{sf}} = \frac{300 \times 0.394}{14.382 \times 50000}$	164.37 $\mu$ H	30 $\mu$ H
Output Capacitor	$C_{batt} = \frac{D_b V_{bat}}{f_s (V_{bat}^2 / P) \times V_{bat}} = \frac{0.394 \times 65}{50000 \times (65^2 / 850) \times 0.01 \times 65}$	1.585mF	2mF

**5. CONTROL OF PROPOSED EV CHARGER**

The DC link voltage of PFC cuk converter is maintained constant using single loop voltage feedback control, which reduces the charger cost due to use of single voltage sensor. The governing equations for error, and control signal at n<sup>th</sup> sampling instant, are given as

$$V_{Cuke}(n) = V_{Cukref}(n) - V_{Cuk}(n)$$

$$C_{vCuk}(n) = C_{vCuk}(n-1) + K_{pCuk} \{V_{Cuke}(n) - V_{Cuke}(n-1)\} + K_{iCuk} V_{Cuke}(n)$$

The gate pulses to Cuk converter switches  $S_{1,2}$  are obtained after comparing the control signal  $C_{cuk}$  to a sawtooth carrier waveform  $S_c$  with higher frequency such as

$$\text{for } v_s > 0; \text{ or } v_s < 0; \begin{cases} \text{If } S_c < C_{vCuk} \text{ then } S_{1,2} = 1 \\ \text{If } S_c \geq C_{vCuk} \text{ then } S_{1,2} = 0 \end{cases}$$

### 6. SIMULATION

MATLAB Simulink is a data flow graphical programming language tool for modeling, simulating, and analyzing dynamic systems.

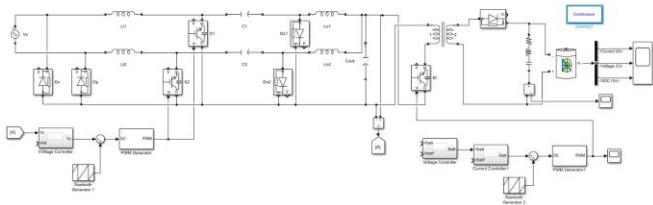

### 7. EXPERIMENTAL RESULTS

A prototype of proposed charger is developed to validate the power quality performance of proposed EV charger to charge an EV battery in constant current and constant voltage mode. The performance of proposed BL Cuk PFC converter fed charger is evaluated under the following subparts.

#### A. Performance of Charger at Steady State(220V)

The proposed EV charger performance is demonstrated under steady state operation, as depicted in Figs. 4 (a)-(c). It is evident in Figs that the proposed Cuk converter is controlled at constant 300V to maintain the required charging voltage at the battery terminals.

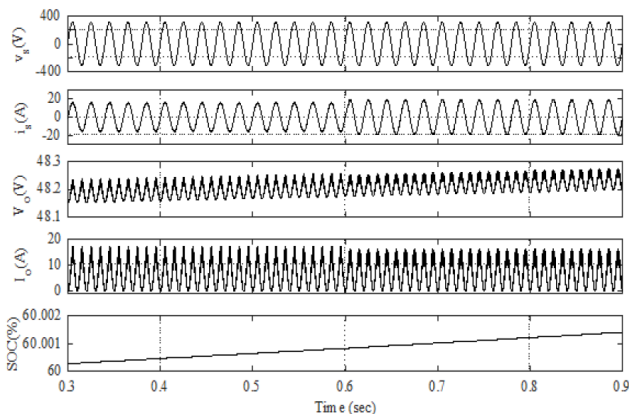

4 (a) Input and Output side wave forms

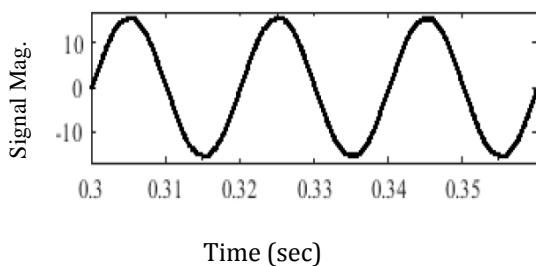

4 (b) Source current waveform

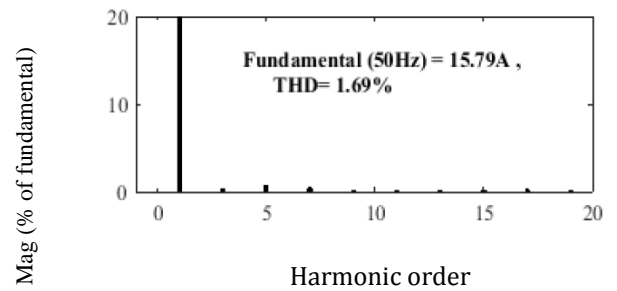

4 (c) Source current harmonics spectrum

#### B. Performance of Charger at Sudden Increase (270V)

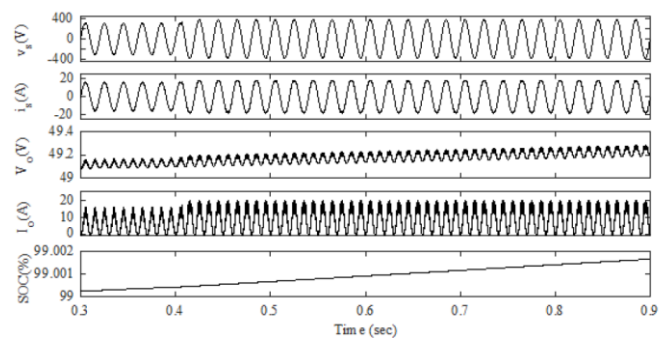

5(a) Input and Output side wave forms

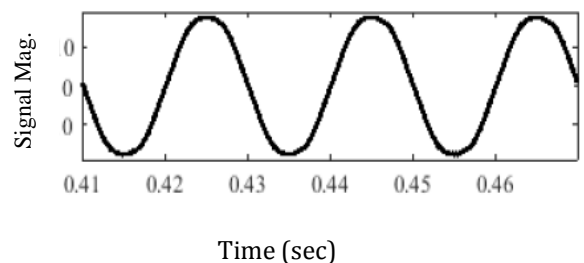

5(b) Source current waveform

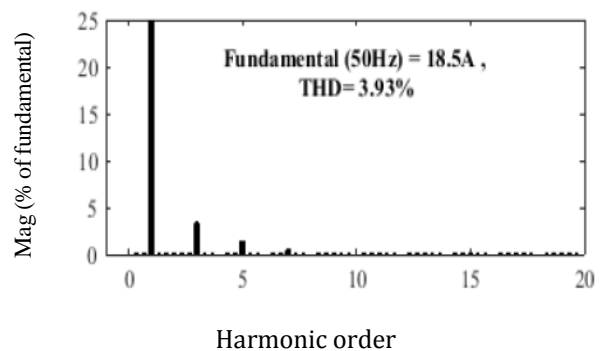

5(c) Source current harmonics spectrum



**C. Performance of Charger at Sudden Decrease (170V)**

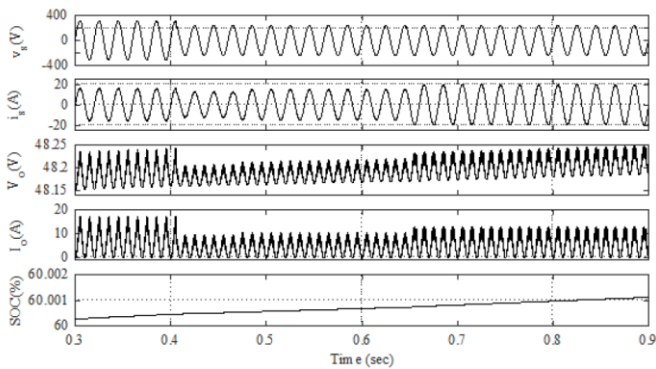

6(a) Input and Output side wave forms

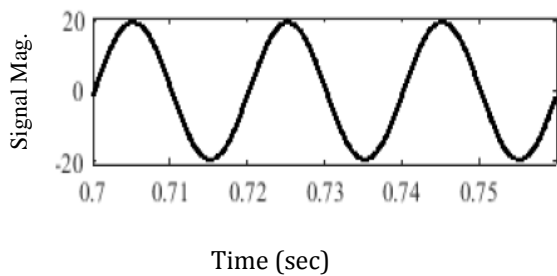

6(b) Source current waveform

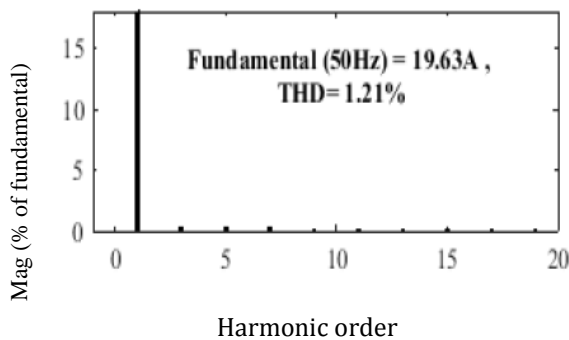

6(c) Source current harmonics spectrum

Table 2 Output Comparison for different voltages

Input voltage(V)	Output voltage (V)	Output current (A)	THD(%)
	[48-50]	[ < 20 ]	[ < 5% ]
220	48.1- 48.3	15.79	1.69
270	49 - 49.3	18.5	3.93
170	48.15 - 48.25	19.63	1.21

**8. CONCLUSION**

A new BL Cuk converter based EV charger with less number of components conducting over single switching cycle is proposed. The proposed PFC Cuk converter offers excellent

PFC characteristics in DCM mode using single voltage feedback control. Therefore, the size of the charger is reduced. The proposed charger shows satisfactory charging characteristics for steady state and sudden fluctuations in source voltage. The charger shapes the mains current to follow the mains voltage as well as the THD in supply current is reduced as low as 2.8%, unlike the mains current THD of 55.3% in conventional charger. Therefore, the proposed charger offers the feasible EV charging alternative for improved power quality and efficiency.

**REFERENCES**

1. C. Chan and K. Chau, "Power electronics challenges in electric vehicles," in Proc. IEEE IECON'93. pp. 701-706.
2. Limits for Harmonics Current Emissions (Equipment current <16 A per Phase), International standards IEC 61000-3-2, 2000.
3. Bhim Singh, Brij N. Singh, Ambarish Chandra, Kamal Al-Haddad, Ashish Pandey, and Dwarka P. Kothari. "A review of single-phase improved power quality AC-DC converters," IEEE Transactions Industrial Electronics, vol.50, no. 5, pp.962-981, July 2003.
4. L. Huber, Y. Jang, and M. Jovanovic, "Performance evaluation of bridgeless PFC boost rectifiers," IEEE Transactions Power Electronics, vol. 23, no. 3, pp. 1381-1390, May 2008.
5. B. Zhao, A. Abramovitz and K. Smedley, "Family of bridgeless buck-boost PFC rectifiers," IEEE Transactions Power Electronics, vol. 30, no. 12, pp. 6524-6527, Dec. 2015.
6. D. S. L. Simonetti, J. Sebastian, F. S. dos Reis and J. Uceda, "Design criteria for SEPIC and Cuk converters as power factor preregulators in discontinuous conduction mode," in Proc. International Conference on Industrial Electronics, Control, Instrumentation, and Automation, 1992, pp. 283-288 vol.1.
7. A. A. Fardoun, E. H. Ismail, A. J. Sabzali and M. A. Al-Saffar, "New Efficient Bridgeless Cuk Rectifiers for PFC Applications," IEEE Transactions on Power Electronics, vol. 27, no. 7, pp. 3292- 3301, July 2012.
8. T. J. Liang, K. H. Chen and J. F. Chen, "Primary Side Control For Flyback Converter Operating in DCM and CCM," IEEE Transactions Power Electronics, vol. 33, no. 4, pp. 3604-3612, April 2018.
9. K. Yao, X. Ruan, X. Mao and Z. Ye, "Variable-Duty-Cycle Control to Achieve High Input Power Factor for DCM Boost PFC Converter," Transactions Industrial Electronics, vol. 58, no. 5, pp. 1856-1865, May 2011.
10. SAE Electric Vehicle and Plug-in Hybrid Electric Vehicle Conductive Charge Coupler, SAE Std. J1772, 2010.