

SPEECH AND FACE RECOGNITION BASED LOCKER SECURITY SYSTEM

P. Pavani Prapura¹, Y. Sai Sreeja¹, P. Naga Babu², P. Bhargav³, V. Bharath⁴

¹Assistant Professor, Dept. of Electronic and Communication Engineering, Dhanekula Institute of Engineering and technology, Andhra Pradesh, India

²⁻⁴Bachelor of Technology, Dept. of Electronic and communication engineering, Dhanekula Institute of Engineering and Technology, Andhra Pradesh, India

ABSTRACT: Security and Authentication of individuals is necessary for our daily lives especially in Bank lockers. A smart digital door lock system for bank automation is equipment that uses digital information such as a user's data, voice detection, and face recognition as the method for authentication in the system. In this system the bank will collect the biometric data of each person for accessing the lockers. Only authenticated people can recover the money, documents from the lockers as biometric and faces are stored for the individual identity of a person. A bank locker system proposed here consists of Node MCU, Raspberry pi, motor module for opening and closing of the door, communication module for giving the notification. As the locker is the safest place, the bank automation function in the digital locker system enables users to conveniently control and monitor the digital locker environment.

customers and fakers, is by and by delivering interest. All things considered, passwords, ID cards and PIN check techniques are being used anyway. The obstacle is that the passwords could be hacked and a card may be stolen or lost. The most secured system is an interesting imprint affirmation in light of the fact that a one of a kind finger impression of one individual never organs the other.

1.1 EXISTING SYSTEM:

In the existing system we have used buzzer alerts in case any unauthorized persons tries to open the locker. And we have used RFID and for detecting authorized persons. For this RFID can be used by anyone so that no safety and security is available. If the RFID tag is stolen, then the person needs to worry about as the tag itself has the info about the bank locker details. Drawbacks.

- No safety and security.
- Card is Compulsory.
- Stolen chances are high.

2. LITERATURE SURVEY

In the olden days, only mechanical locks were available which were not secured enough. As technology grows, modern electronic locks were introduced into the market to avoid further theft and unauthorized access. Password based locking system was one of the modern electronic lock systems where password is used as the verification factor. Then comes the next electronic lock system which is an RFID based system. Where RFID tag and reader are the main components and RFID value acts as the authentication factor. Later on the biometrics lock system came into existence such as face recognition, fingerprint recognition, voice recognition, iris recognition and identification and work on the principle "what we are". Here the personal identification of each individual is used as the factor for verification. An encryption based lock system was introduced where the original password was encrypted to generate the new password which has been used to unlock the door. This technique is mainly introduced to prevent hacking. q One Time Password (OTP) is the largest technology for secure access. The OTP generated will be unique at each time of access and chances of hacking will be very low and is difficult. They

Keywords: locker, voice, IOT, security, Raspberry pie.

1. INTRODUCTION

Security is of fundamental concern and in this occupied, cantered world, humans can't find ways to deal with offering security to his mystery resources physically. Or maybe, he finds an elective which can give a certain security and moreover atomized. In the inescapable system society, where individuals can without quite a bit of a stretch access their information at whatever point and wherever, people are also looked with the peril that others can without a doubt get to a comparable information at whatever point and wherever.

Bank is an organization which renders economic efficiency and extends financial services like issuing cash, saving belongings and further on. The critical aspect in an individual's life is saving and securing the money earned to pertain one's economic popularity. It is necessary to maintain the valuables under secure custody because burglars nowadays have a whole lot of modern-day equipment with them. According to one citation, if one loses health it could be regained, but if one loses his valuable wealth it takes an excessive amount of time to remember it. To defend our valuables banks, provide some other advantages like offering their clients with protection lockers to store their valuables.

In perspective of this danger, individual unmistakable verification advancement, which can perceive enlisted real

are enhanced version of password based lock system, but the password are not consistent. There are many more methods like IOT, Wi-Fi and Near Field Communication (NFC) based lock systems which work with the help of smart phones and networks. But that doesn't even put an end to the theft, hacking and unauthorized access. Hence it leads to the implementation of the proposed system.

3. PROPOSED METHOD

In this proposed system we are using face recognition as well as Voice recognition. So that to open a bank locker then the person's face and voice should be matched otherwise the locker won't open. For face detection we are interfacing Webcam with raspberry pi and for voice we are interfacing Node MCU with Raspberry pi.

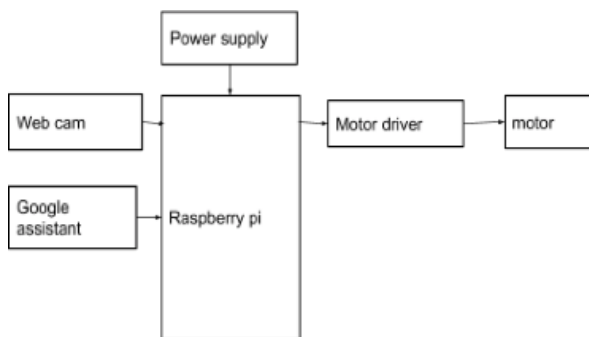

Fig-1. Block diagram

3.1 Flow chart:

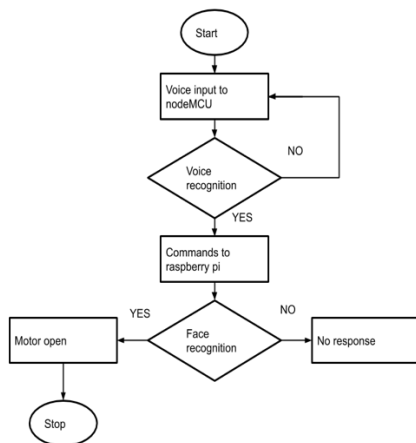

Fig-2. Flow chart

3.3 Design procedure:

Step 1:

Circuit diagram of the proposed system is designed and finalized.

Step 2:

All the components and software platform to be used are selected which are also mentioned above.

Step 3:

All the hardware components such as raspberry pi, node MCU, Logitech camera etc are attached to the wooden board board power supply and remaining connections are given as mentioned as above.

Step 4:

Code/program of the proposed system is developed using embedded C language and python programming with the help of the software platforms Arduino IDE and Raspberry OS respectively.

Step 5:

The code is dumped into the Raspberry pi and node MCU.

Step 6:

Testing is done at various levels to finalize the appropriate program for the working of the system.

3.4 Working:

For face and voice recognition Bank locker we are using Face as well as voice to open the locker.

To open locker by using Face we are interfacing Camera to Raspberry Pi:

The implementation takes place in three steps.

1. In first step we have capture the authorized person's faces using camera which is interfaced with raspberry pi.
2. After capturing we need to store them in a database. For each face it will give one unique digital ID.
3. After giving ID then if we want to open the locker then it will match the faces and open the Locker.

To open locker by voice:

Identification to open the locker by using Voice we will use Google voice assistance and this will be interfaced with Node MCU.

Advantages:

- Less power consumption.
- Real time observation.
- Highly secured.

Applications:

- In banks.
- In town areas.

4. RESULTS

Hardware Images:



Fig-3. Raspberry pi



Fig-4. Logitech camera



Fig-4. Top view of the project.

5. CONCLUSION AND FUTURE SCOPE

5.1. Conclusion

Implicit guarantee of your money inside the bank being safe has usually been the reality of concern. This project plays a first-rate function in maintaining the safety and safety of the respective valuables, financial institutions being the utmost priority. The proposed device is reliable, inexpensive with a suitable layout. This undertaking High Protection Voice Identification based Bank Locker Security

System with Live Image Authentication ensures to promote encouraging and improvised results, improving the safety and secureness over the presently present technologies.

5.2 Future Scope

Development of the project can be done in many ways where voice can be replaced by iris detection which is more effective or it can also be replaced by using the biometric system which also helps to improve the security. Security can also be improved by using the GSM technology in which the user gets the message if the locker is opened by some other people.

Reference:

1. K. Suganithi, "Survey of integrating Face and Iris biometrics for security motive using change detection mechanism", International conference on science technology, 2017.
2. Avinash. D. Harale, "Iris as a Biometrics for Security System ", SKN sinhgad college engineering korthi, Maharashtra, india, 2017.
3. N. Anusha, "Locker security system using Facial Recognition & OTP", computer science and engineering sathyabama university chennai, 2017.
4. Pradeep Kumar, "An efficient multi stage security system for user authentication", department ECE Amity university, 2016.
5. Divya R.S, "Super secure door lock system for critical zone". International conference on network & advance in computational technology, 2017.
6. Sanal Malhotra, "Banking security system using Hand Gesture Recognition", Department of ECE amity university uttar pradesh, 2015.
7. K. Suganithi^2, "Survey of integrating Face and Iris biometrics for security motive using change detection mechanism", International conference on science technology, 2017.
8. A.S. "Performance Analysis of speech digit recognition using Cepstrum and vector quantization", International Conference on Electrical, Electronics, Communication, computer and Optimization Techniques(ICEECCOT), 2017.
9. Azzam Ul Asar, "Interactive Voice Response with Pattern Recognition Based on Artificial Neural Network Approach", NWFP University of engineering and technology, 2017.
10. Anitha Julian, "Design and implementation of anti-theft ATM machine using embedded systems", International conference on circuit, power and computing technology, 2015.