

“AN INVESTIGATION OF CAUSES OF FAILURES OF INDUCTION MOTORS IN STONE CRUSHER APPLICATIONS AND TO IDENTIFY REMEDIES TO OVERCOME FAILURES”

Mr. Pawar Nikhil¹, Dr K.B.Kale², Mr. Khemnar Valmik³

¹PG Scholar, Mechanical Engineering Dept. PDVVCOE, Ahmednagar

²HOD, Mechanical Engineering Dept. PDVVCOE, Ahmednagar

³PG scholar, Mechanical Engineering Dept. PDVVCOE, Ahmednagar

Abstract – The squirrel-cage induction motor remains the workhorse of the manufacturing region because of its versatility and ruggedness. However, it has its boundaries, which if passed will reason premature failure of the stator, rotor, bearings or shaft. A tiny disorder or a easy crack may additionally result in intense damages to rotating machines. As a end result, it is crucial to reveal the fitness situation of rotating machines thru lively diagnostic and prognostic technologies. For all styles of industry, a machine failure escorts to a diminution in production and cost will increase. The circumstance monitoring of the electric machines can appreciably lessen the prices of preservation through permitting the early detection of faults, which might be highly-priced to repair. On this paper various reasons, its effect & treatments of mechanical failure of stone crusher software induction motor are recognized.

Key Words: Index Terms— AC motor, mechanical failure, FMEA, failure analysis, failure methodology, root cause, cause & effect diagram, RPN

1. INTRODUCTION:

In a huge type of manufacturing application, an rising call for exists to improve the reliability and availability of electrical systems. Famous examples consist of structures in aircraft, electric railway traction, power plant cooling or commercial production strains. A surprising failure of a system in those examples may additionally lead to cost highly-priced downtime, damage to surrounding equipment or maybe threat to humans. Tracking and failure detection improves the reliability and availability of an current gadget. In view that numerous disasters degrade incredibly slowly, there may be potential for fault detection accompanied by way of corrective preservation at an early level. This avoids the surprising, general gadget failure that can have serious consequences. Electric powered machines are a key element in lots of electric structures. Among all varieties of electric powered automobiles, induction vehicles are a frequent

instance due to their simplicity of creation, robustness and excessive performance. Not unusual failures happening in electric drives may be more or less labeled into:

electric faults: stator winding quick circuit, damaged rotor bar, broken quit-ring, inverter failure mechanical faults: rotor eccentricity, bearing faults, shaft misalignment, load faults (unbalance, gearbox fault or preferred failure in the load part of the drive), dust ingress, bearing failure. A reliability survey on big electric powered cars (>two hundred hp) found out that most screw ups are because of bearing (>forty four%) and winding faults (>26%). In stone crusher software, most of the failures are passed off because of failure of bearing, winding harm, shaft failure, foot breakage & dust ingress affecting cooling of motor. If we're able to conquer these failures of crusher application motor, then it's going to genuinely enhance the existence & output of induction motor & ensuing in less wreck down in industry & savings in phrases of money.

1.1 1.1 Problem Statement:-

India is the most important marketplace for the producing enterprise within the international. Presently industries are operating at extraordinary ability. In enterprise, use of walking additives is huge & prime mover used for those packages is especially induction motor. In this studies, area of application is chosen 'stone crusher'. In stone crusher, large stones are broken down in to small pieces. At some stage in this process, mechanical additives of motor undergoes in huge non-stop vibrations, heavy radial, axial or concurrently performing each radial as well as axial hundreds on shaft ensuing in shaft damage or breakage, foot breakage because of continuous heavy vibrations, bearing failure, winding failure, etc. If motor ruin down, enterprise has to suffer from massive losses in terms of production loss and cash. Mechanical and electrical failure fee of induction motor is excessive in stone crushers as compared to other sectors. So, fundamental interest of this studies is to investigate causes of mechanical disasters of induction

motors in stone crusher programs and to pick out remedies to overcome these disasters.

1.2 Objectives:-

The purpose of this work is to study different causes of mechanical failures of induction motors used in stone crusher and to find different solutions to overcome these failures using ANSYS software, FMEA techniques, cause and effect diagrams. And also to suggest design change, preventive actions or material change if necessary for various components in motor.

2. Literature Review

2.1 Review of book, journal and international research papers.

From study of literature it's far understood that, once we find out the faults before it is going to be existed inside the motor, we are able to rectify or can take precautions. So we are able to reduce the motor failure and also will increase the provision, reliability, overall performance of the motor.[1]

Crushing of boulders cause production of massive quantity of dust, which is likewise a root reason of winding failure, cooling circuit failure of motor. Also this dust is risky for human health. Noise is any other trouble created with the aid of the crusher enterprise. As heavy materials and machines are used in the industry, to keep away from noise is not viable. [2]

There are numerous faults in induction motors. The specific faults classifications are based at the inner and outside sort of essential faults happening in the system. The inner faults are positioned under mechanical fault and electrical fault categories. While the outside fault placed underneath electrical, mechanical and environmental fault. Those faults produce mechanical vibration, unbalanced air hole voltages and line contemporary, multiplied torque pulsation, reduced average torque, increased losses, reduction in performance and motive immoderate heating. [3]

A reliability survey on large electric cars (>200 hp) found out that maximum disasters are because of bearing (>forty four%) and winding faults (> 26%) ieee motor reliability running organization. Similar consequences had been acquired in an eprl (electric strength research institute). [4]

A tiny illness or a simple crack may additionally bring about excessive damages to rotating machines. As a end result, it's far crucial to monitor the health circumstance of rotating

machines via energetic diagnostic and prognostic technology. In current years, many detection strategies had been developed. Those technology consist of vibration analysis, thermography analysis, acoustic evaluation, flux evaluation, and many others. [5]

3 Experimental Methodology

3.1 Data collection of complaints

Data of failure of motors from April 2017 to March 2018 is analyzed for different complaints received from different customer. Results obtained is as follows:

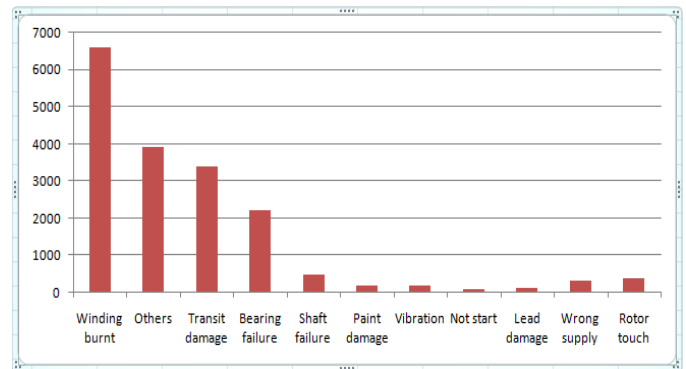

Fig. 3.1.1 Customer complaints (Apr 2017-Mar 2018)

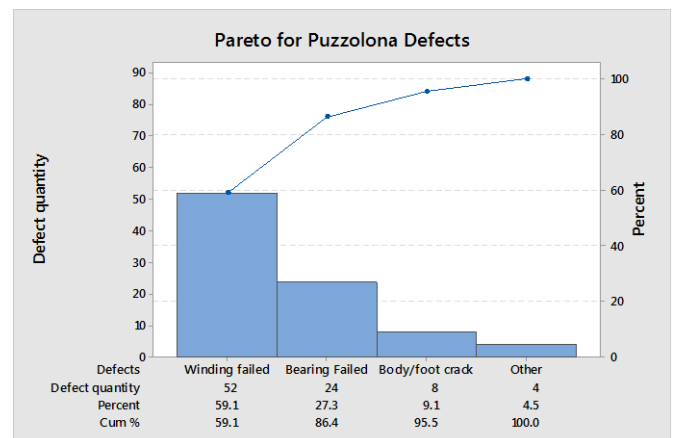

Fig. 3.1.2 Complaints from major crusher customer (Apr 2017-Mar 2018)

After studying client court cases, it's miles determined that, complaints acquired are majorly of winding failure, excessive body & winding temperature, bearing failure, shaft breakage or crack development in shaft, paint harm, and so forth. So, after this analysis & discussions, place of awareness for improvement in motor are decided, that are:

1. Cooling circuit development to lessen winding failure & to lessen body in addition to bearing temperature

2. To lessen transit damage, development in packing scheme

3. Improvement in shaft layout to reduce strain attention because of heavy radial & axial loads performing constantly

3.2 Site Visit



(a)

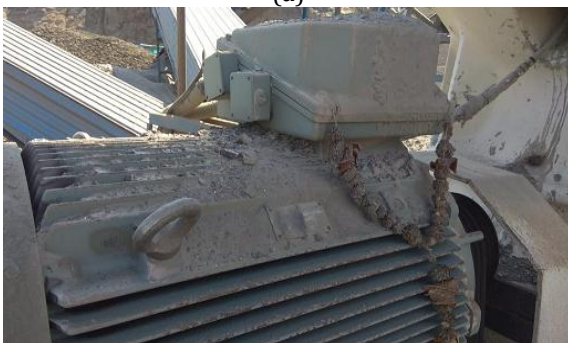

(b)



(c)

Fig. 3.2.1 Site visit to different customers

After site visit observations, some problems observed which may be the reasons for failure of motor.

1. Blocking of path direction between fins due to dust and stones particles blocked in blank spaces.
2. Open terminal box
3. Excess vibration
4. Inefficient V seal protection for bearing

3.3 FMEA for crusher motor

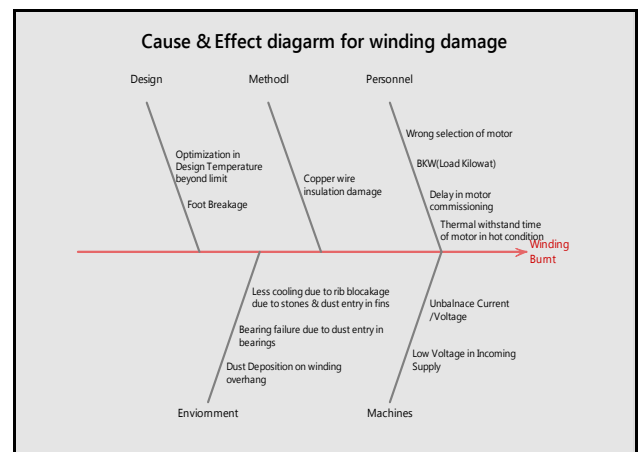

(a)

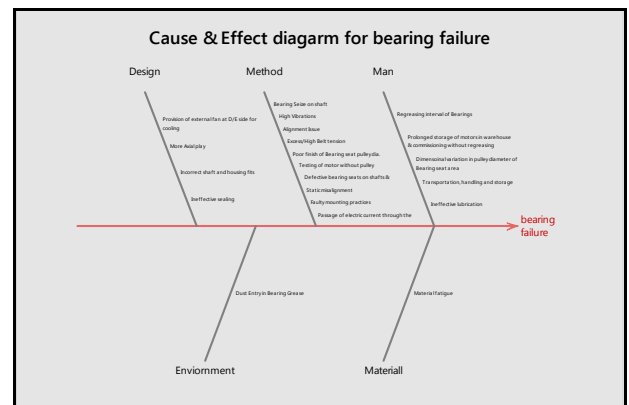

(b)

Table 3.4.1 RPN calculation

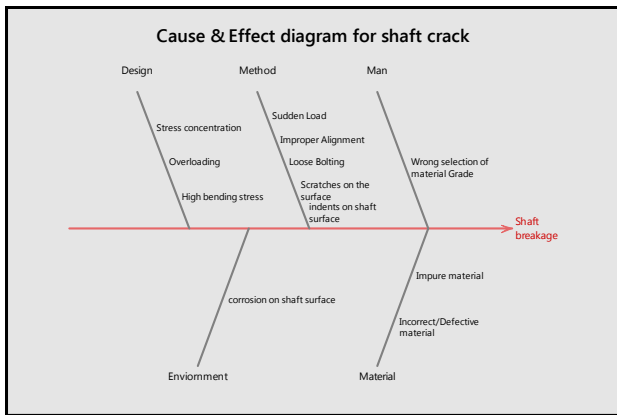

(c)

Sr. No.	Critical Xs	RPN
1	Gap between cable outside dia. & terminal box gasket	576
2	Stone dust entry to winding overhang through gap between v seal & bearing cover	576
3	Less contact area due to shorter length studs	256
4	Loosening of studs in stator body	256
5	Less number of fins near base area	256
6	Measures to avoid coil insulation not followed	256
7	Inadequate strength of shaft material	128
8	Crack development due to stress concentration	128
9	Increased temperature on DE side	128
10	Lack of education to operating people at site regarding greasing of bearing	128

Fig. 3.3.1 Cause and Effect diagram for motor failure

3.4 Critical Xs through FMEA

$$RPN = S \times O \times D$$

RPN: Risk Priority Number,

S: Severity,

O: Occurrence,

D: Detection,

Severity: The severity of the failure mode is ranked on a scale from 1 to 10. A excessive severity ranking suggests immoderate risk. Occurrence: the capacity of failure occurrence is rated on a scale from 1 to ten. A immoderate incidence rank presentations immoderate failure prevalence capability. Detection: the functionality of failure detection is ranked on a scale from 1 to 10. A high detection rank reflects low detection functionality.

4. Improvements in designs

After analytical calculations for RPN, some design changes are carried out for improvement in the existing designs.

1. To prevent ingress of stone dust inside motor body, sealant is applied against mating surfaces of DE/NDE endshield and stator body, terminal box and stator body, terminal box and terminal cover, bearing cover and DE/NDE endshield, etc.
2. Use of barrier plate between terminal box and stator body with both side locking rubber grommet
3. Application of RTE sealant on TB inside facing
4. Increased foot supporting rib thickness and foot
5. Radius at shaft corners instead of undercut to reduce stress concentration
6. Replacing V-seal with oil seal
7. Use of EN24 forged material over EN24 rolled material.

4.1 Terminal box improvements

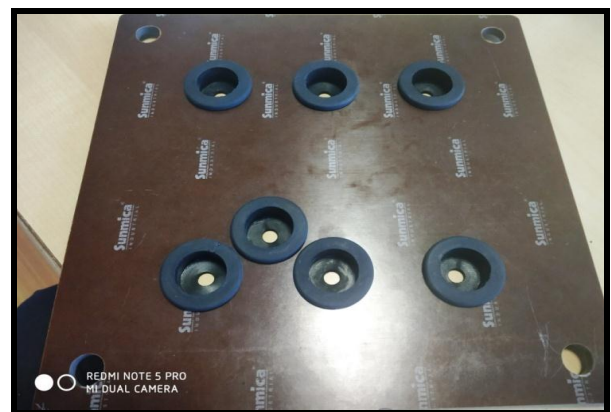

4.1.1 Barrier plate with rubber grommets

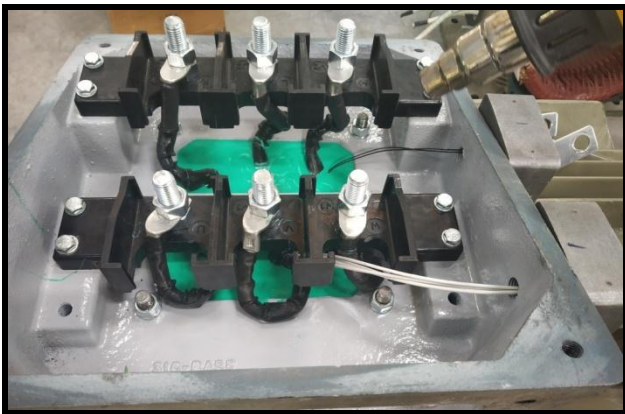

4.1.2 Terminal box assembly with RTE sealant

To restrict ingress of stone dust inside body on overhang, some modifications done in construction of terminal box for dusty environment.

4.2 Analysis of stator body

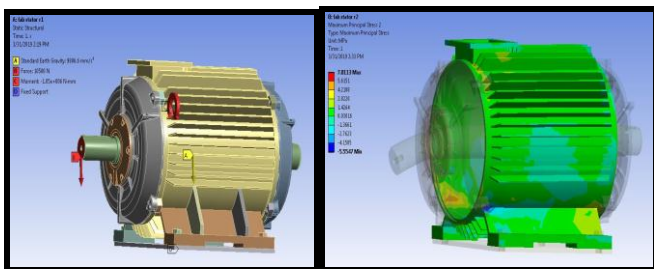

Fig. 4.2.1 Analysis of stator body in ANSYS

During analysis in ANSYS, some stress concentration observed near foot and foot supporting rib and body. So, to reduce this stress, foot and foot supporting rib thickness in increased from 15mm to 18mm and foot thickness increased to 25mm from 20mm.

4.3 Material and design change for shaft

Category	EN24-Rolled	EN24-Forged
Tensile strength(min)	850N/mm sq.	850-1000N/mm sq
Yeild Strength(min)	650N/mm sq	650N/mm sq
% Elongation	13	13
Hardness(BHN)	248-302	248-302

Table 4.3.1 EN24 Rolled Vs EN24 Forged

Use of EN24 forged material in recommended instead of EN24 rolled.

Forging provides better mechanical properties, ductility and fatigue and impact resistance because this process refines and directs the grain flow according to the shape of the piece.

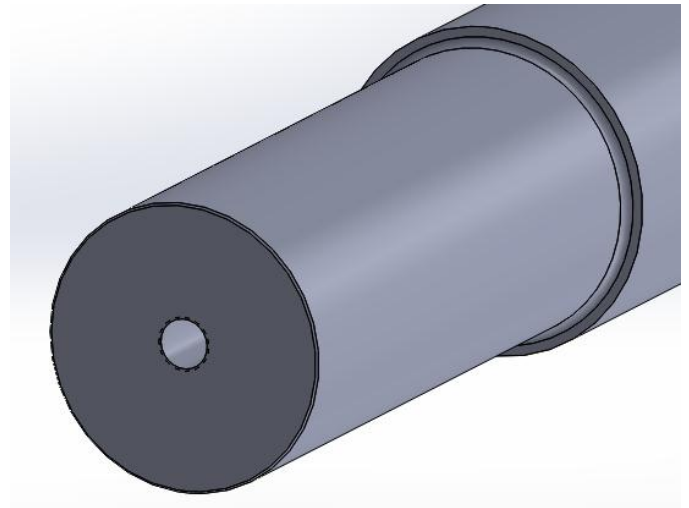

Fig. 4.3.1 Fillet at shaft corners

To reduce stress concentration at shaft corner, instead of undercut, fillet of 2mm is given.

4.4 Replacement of V-seal with oil-seal

Oil seals have the capability to work under extreme duress in terms of temperature. This makes them perfect for fluid environment applications. Sealing materials such as PTFE and fluoro elastomer ensure that the oil seals can be used for long periods of time.

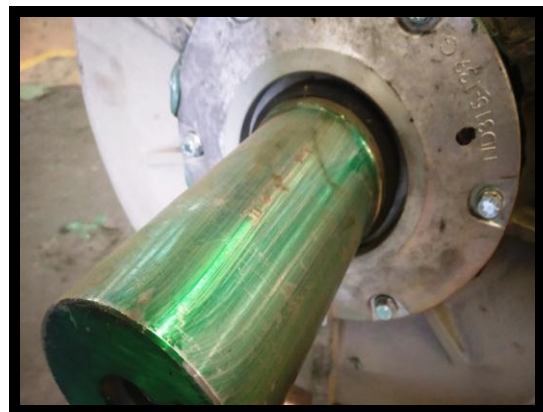

Fig. 4.1.1 Oil seal at DE side

The strength, flexibility, and durability of oil seals provide a number of benefits to various industrial applications.

5. Conclusions

1. Application of silicon sealant between mating faces of endshield, stator body, terminal box and cover improved degree of protection against ingress of dust as well as water.
2. Use of barrier plate with both side locking rubber grommet and application of sealant inside terminal box improved leakage property. Pouring water inside TB and observing for 08 hours, there is no leakage found.
3. Increased foot supporting rib thickness and foot thickness resulted in reduced stresses near foot area. Increased foot thickness resulted in reduced vibrations of motor.
4. Applying radius at shaft corners, stresses developed in shaft get reduced.
5. Replacement of V-seal with oil seal & proper re-greasing of bearing improved bearing life and reduced bearing failure.
6. Use of EN24 forged bar for crusher application improved impact resistance and tensile properties of shaft.

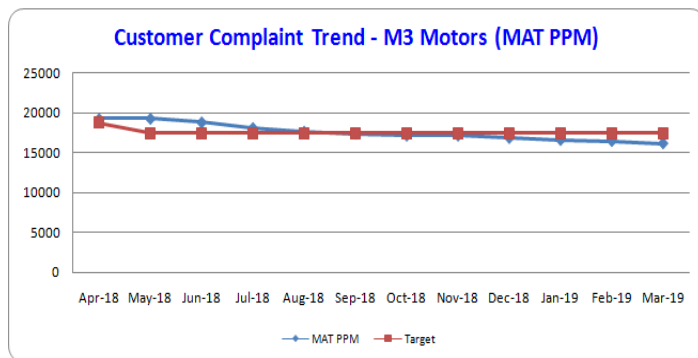

Fig.5.1 Customer complaints trend (2018-19)

After implementing design changes, taking some preventive actions and after giving training of assembly practices to assembly people customer complaint trend found reduced as compared to previous year.

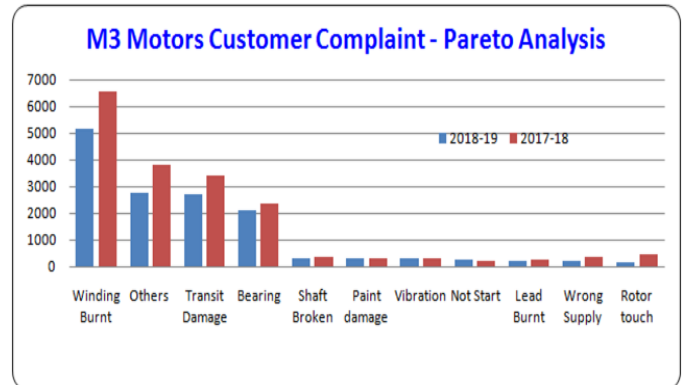

Fig.5.2 Comparison of customer complaints (2017-18 s 2018-19)

References

1. Review paper on Stator and Rotor Fault Diagnosis Of 3-Phase Induction Motors, Yogesh R. Patni, Prof. M.M.Ansari
2. Design and manufacturing of a single-phase induction motor: A decision aid tool approach, Yannis L. Karnavas, Ioannis D. Chasiotis.
3. Review on Fault Diagnosis in Three-Phase Induction Motor, K. K. Pandey, P. H. Zope, S. R. Suralkar
4. Failure analysis of jaw crusher and its components using ANOVA, Ravi Sinha, Indian Institute of Technology (ISM) Dhanbad.
5. Condition Monitoring of Slip-ring Induction Motor, Dipti Agrawal, Mr.Naresh Yadav, Mr.Suresh Saini
6. Stone crushers and dust problems, Dr. S. Ravindran, Dr. N. K. Udhaya Prakash
7. Mechanical fault detection in induction motor drives through stator current monitoring – Theory and application examples, Martin Blödt, Pierre Granjon and Bertrand Raison, Jérémie Regnier.
8. Root Cause AC Motor Failure Analysis with a Focus on Shaft Failures, Austin H. Bonnett.
9. Fault Diagnosis of Rotating Machine, Grzegorz Królczyk, Zhixiong Li, and Jose Alfonso Antonino Daviu.
10. Testing and Analysis of Induction Motor Electrical Faults Using Current Signature Analysis, K. Prakasam, S. Ramesh.
11. Induction Motor Fault Diagnosis Methods: A Comparative Study, Victor Jose.
12. Diagnosis of Mechanical Faults in Electric Motors, Neelam Turk.
13. IS 1231 : 1974(R2008) Dimensions of three phase foot mounted induction motors
14. IS 210: 2009(R2014) Grey iron castings-specification
15. IS 3824-2 (1983): Method of Evaluating Dynamic Load Ratings of Rolling Bearings

16. IS 12075: 2008 Mechanical vibrations of rotating electrical machines with shaft heights 56mm and higher.
17. IS 12065: Permissible limits of noise level for rotating electrical machines : Bureau of Indian Standards
18. IS 8789: 1996. Document Title [Eng-Hn] : Values of performance characteristics for three - Phase induction motors
19. S 6362 : 1995(R2017) Designations of methods of cooling of electrical machines
20. IS 4691: 1985(R2004) | Degree of protection provided by enclosure for rotating electrical machinery.

BIOGRAPHIES



Mr. Pawar Nikhil

PG Scholar,
Mechanical Engineering Dept.
PDVCOE, Ahmednagar