

# Design of Power Cable Monitoring Robot

Prashis S. Arakharao<sup>1</sup>, Professor S.S Khule<sup>2</sup>

<sup>1</sup>Student of M.E Power System Matoshri College of Engineering, Nashik

<sup>2</sup>HOD Department Electrical Engineering, Matoshri College of Engineering, Nashik

\*\*\*

**Abstract** - The observation and maintenance of high voltage cable is the critical part of the power system. Maintenance to operate the power system properly and efficiently the observation and maintenance of system is important. Hence mainly the human resources is used. But using human resources for the maintenance of the power cable is quite risky and hence the this robotic system is mainly design to operated on the high over voltage power cable. The main aim of this system is to minimize the human risk for the maintenance of the power cable. This robotic system mainly have the compact size and multiple robotic arm so that the detail and independent observation can be done by the system. It will not only provide with the real time data but also help greatly in preventive maintenance. Due to it single wheel assembly and two independent robotic arm it has less dynamic limitation and observe freely. This system also has the independent remote controlling system so that the maximum amount of protection provide to the operator.

**Key Words:** Multiple Robotic arm, Real time data, Single wheel assembly ,Independent remote controlling system.

## 1. INTRODUCTION

High voltage power cable are the life of the most of the industry and city. Power is the essential thing I the regular life of the common person. Power transmission from one spot to other spot there are number of elements are include in that process. Power cable is one of the important element in the power transmission system. Now when power cable operated in the open environment for long distances it has to face the environmental condition, server factors are acting on the system hence it is important for the maintenance and observation of the power cable. When power cable operate in open environment the most affecting factor for the cable is the surrounding environment. Various environment actor like humidity, heat, moister are damming the power cable. Hence it is important for the efficient work of the power cable the regular maintenance and operation should done. When maintenance and observation of the system mainly human resources is use. But when human resources operate on the high voltage cable it create problem for the system and human. The human error factor can affect the system. It risk the human life. Hence to maintenance and observation of the power cable various type of method are being use. This method only try to minimize the human to cable contacted but it cannot fully satisfy the system requirement to maintenance and observation.

Following are the some of the method is mainly use for the observation and maintenance of the system. Use of the well trend human resource which can done the maintenance part but with this option the life get in risk also the human error factor. Operating the helicopter for the maintenance and observation of system. This system can only solve the maintenance problem for short amount of time because of the operation limit of the helicopter and amount of time involve this method is to expensive.

Use of the cable maintenance truck this system the special truck is used with the hydraulic lift provide so that operator can operate near the power cable. But due to its limited height and the mobility limitation system has to operate in the specific condition and ground. Use of the drone is the new system but it also has the operation limitation. Due to high voltage and the complex physical structure the system has to operated form the distances. This system also has the operation duration limit. It also has the limited amount of power supply for the observation condition. Hence due to limitation of the old system the fully dedicated system has to develop. Robotics can has the great advantages over this system. Hence by designing the specific system the maintenance and observation of the power cable can be done.

## 2. OBAJECTIVE

The main objective of this system to operator on the power cable for the detail observation of the system. It will not only provide data for the preventive maintainces but also minimize the human risk. The construction and design of this system has done for the specific power cable observation and with multiple robotic arm and specially dedicated sensor can detected any damage to the power cable and help to maintain the system properly.

## 3-SYSTEM OVERVIEW

This system has the multiple system assembly. Each system is provide with the independent process. Due to the multiple motor assembly system has the different mechanical as well as electrical assembly.

Following are the main three part of the system

- Mechanical system
- Electrical system

Controlling system

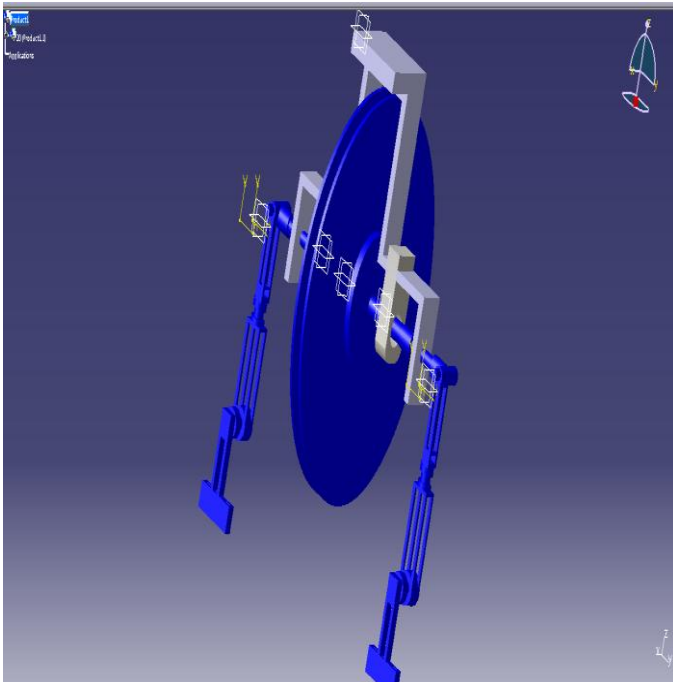

FIG -1 System assembly side view.

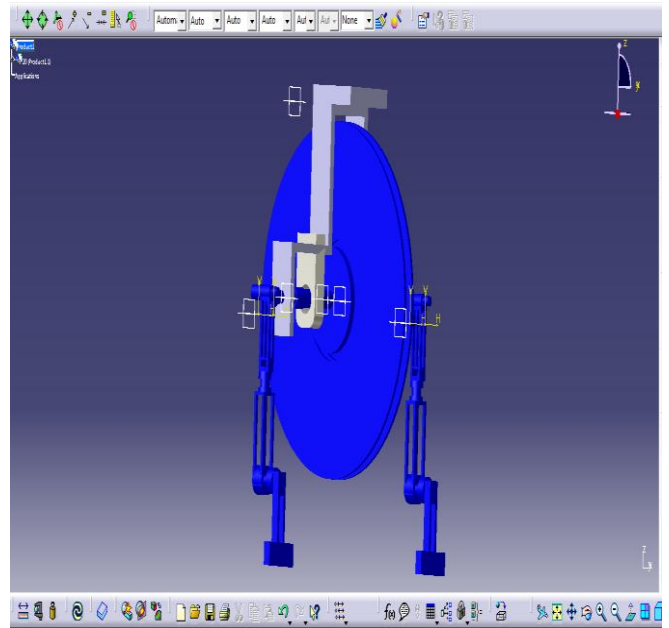

Fig -3 System side view

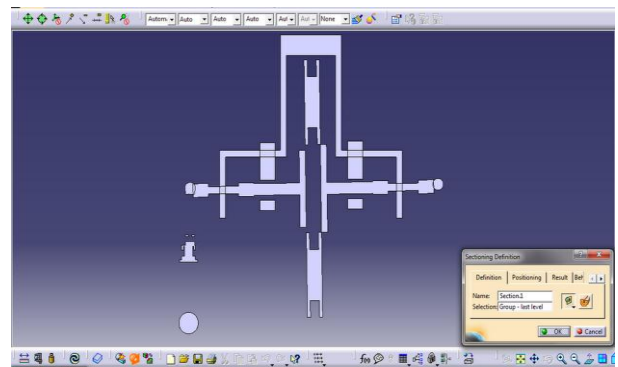
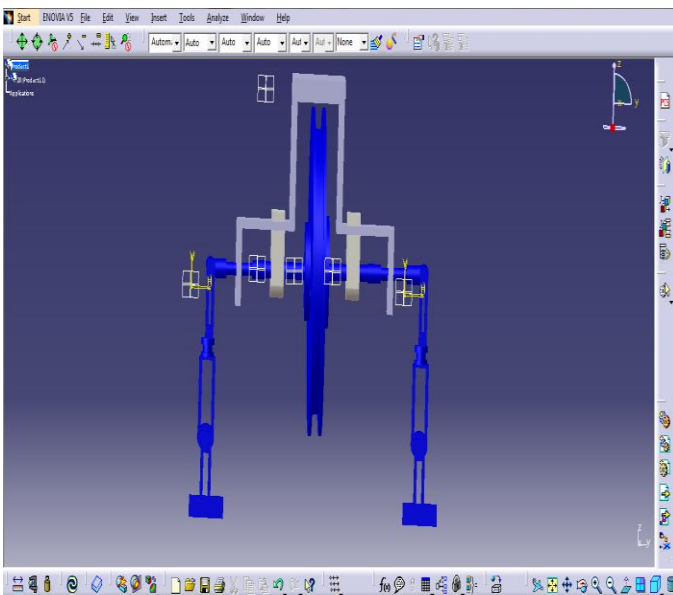
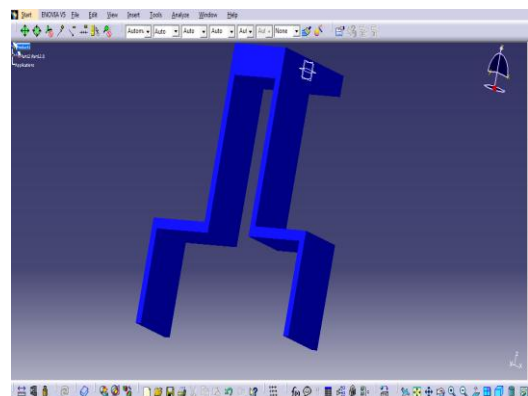

Fig -4 System section view

3.1-MECHANICAL SYSTEM

The mechanical system consists of the various elements such as the mechanical frame work, internal wheel assembly, two independent robotic arm.

3.1.1MECHANICALFRAME



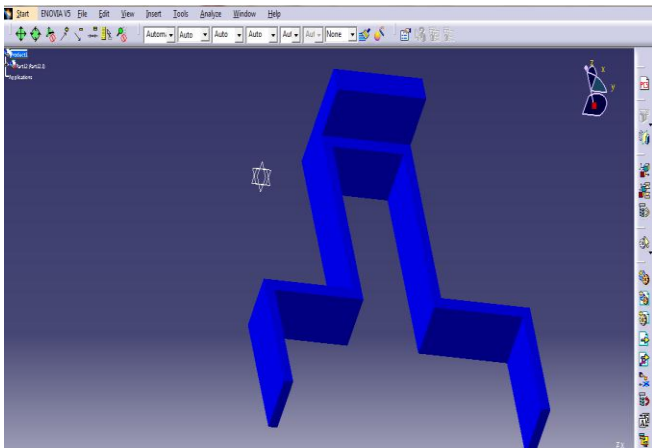

Fig-6 Mechanical frame

Mechanical frame systems mainly provide support to the entire system. It consists of the two joining arm so that the external robotic arm assembly can joint to it. It also provides the detail space for the internal wheel assembly so that it can move freely without any dynamic limitation. The upper surface of the mechanical frame is provided with the minimum amount of material so that the least amount of surface will come contact with the other conductor. Due to it has provide the least and compact structure the system will need minimum amount of material and also has the move dynamic stability as compare to the bulky structure.

**3.1.2-INTERNA MOTOR SYSTEM**

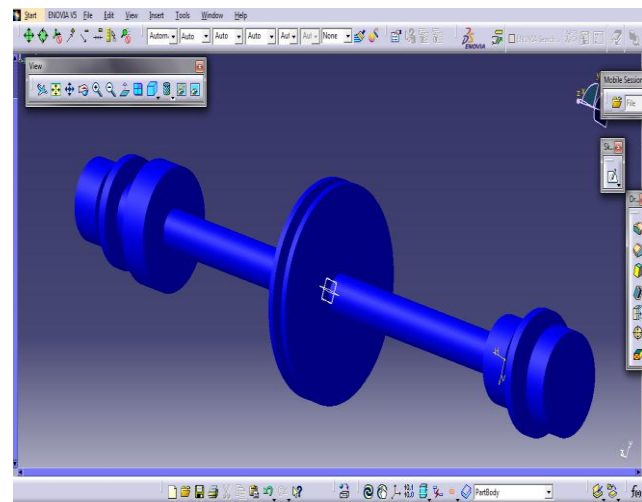

Fig-7 Internal motor assembly

The internal motor system is the informant part of the system it will provide the dynamic ability to the system. It mainly consist of the internal wheel system and the two different motor system connected to the single join system. The internal structure of the system in which the mainly two different motor are conned to the single so system where the mainly wheel which operate on the cable as fixed.

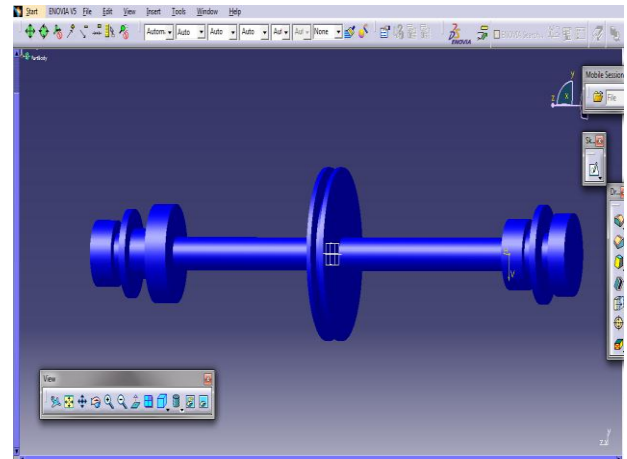

Fig 8- Internal motor Front view

The system has the well single joint rod structure so that it will provide additional support for the wheel system. It will also give support for the wheel internal weight. When the internal wheel system operate it will control by the specially dedicated controlling unit hence it has more control over the movement of the robot. In this system two motor which are place in oppsite direction will do the same rotation movement so that it will create the same dynamic condition result it will move in forward and backward direction as the joy stick control the movement of the motor.

Following diagram will give a detail operation of the internal wheel assembly. This internal wheel assembly is also externally connected to the two different robotic arm which are connected at the joined end of the end motor .Hence it cover the all direction movement.

**3.1.3-ROBOTIC ARM ASSEMBLY**

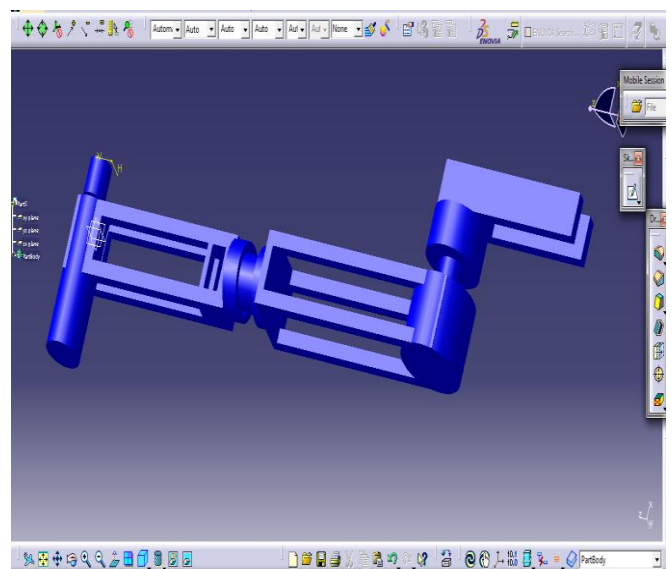

Fig-9 Three joint Robotic Arm



This system is providing with the specific two different robotic arm assembly which were mainly connected to the internal wheel assembly system. The main purpose of the robotic arm is to monitor the power cable system in close condition. This robotic arm has the three joint systems where each motor is move in free 360 degree direction.

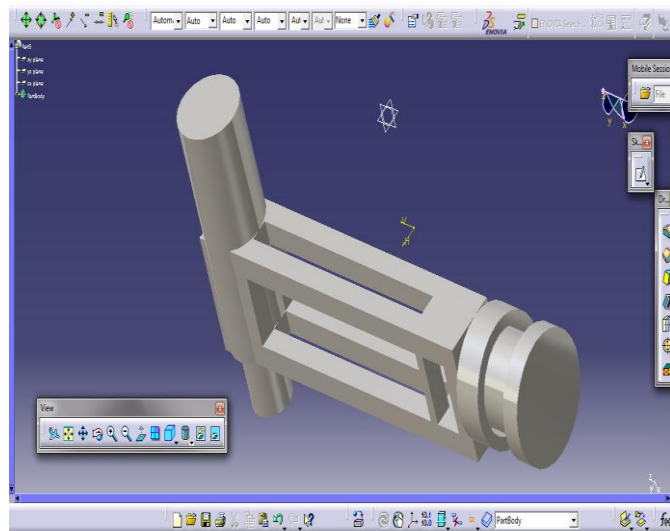

Fig -10 Secondary joint in Robotic arm

This robotic system is specially design for the free movement system hence at has provided with the three motor so that for observation it does not has dynamic limitation. Robotic arm in system is provide with the base motor which cam move in 360 degree in vertical and horizontal direction this will provide the robotic arm the upper and lower power cable observation condition. The internal knee joint motor is also move in the 360 degree but it movement is mainly focus on the providing the support to the third motor and the sensor box of the robotic arm system can also move in the 360 degree. The end motor of the robotic arm is mainly connected to the sensor box. It can move 1 360 degree in horizontal and vertical direction the advantage of this system is that it can provide the movement to the sensor box so that it can observe the power cable surface very closely.

The structure of the robotic arm in mainly plastic in nature hence it will provide the maximum amount of protection for the internal motor as well the robotic system. It will also provide the minimum weight condition. In usual case the robotic arm link are made of the solid and continues part which increase there weight but in this robotic arm the joining link are manly design to minimize the internal material so that it can be weight less and also provide the equal amount of the protection.

### 3.1.4-INTRENAL AND ROBOTIC ARM ASSEMBLY

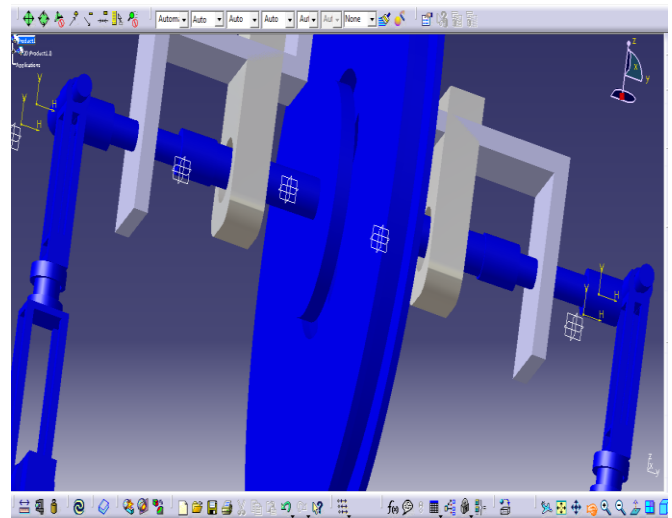

Fig 11- External robotic arm link with internal system

The internal motor and external robotic arm assembly are mainly inter connected. In this system the mainly the outer joint of the internal assembly is mainly connected to the external robotic arm. Now when system has to operate the both system will operate at the same time. Due to this condition the system will performs in the same manner and synchronous condition. The internal and external robotic system is mainly attached with the link in the system .Both system are controlled by the different controlling unit so it has the greater operation capacity.

### 4. CIRCUITE DIAGRAM

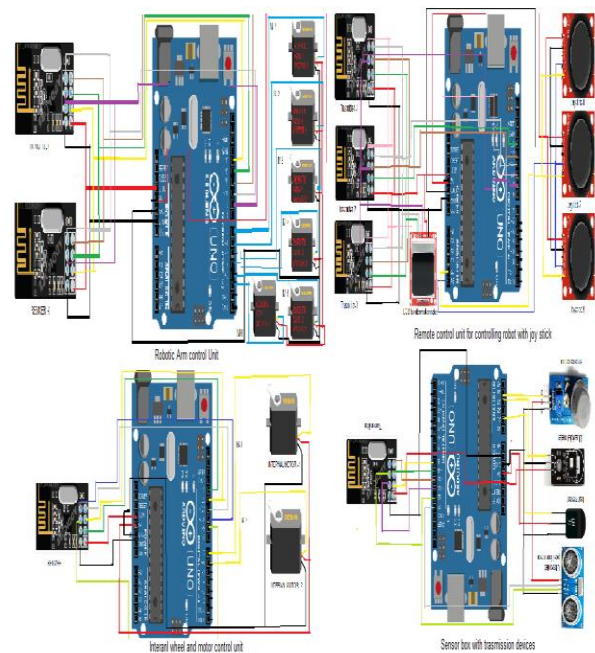

Fig 12- circuit diagram of system

This Robotic system mainly consists of the four different controlling unites. Each system has its own dedicated control unit so that it can operate freely. The internal wheel assembly and the motor are controlled by the specific control unit. This control unit has the transmission and receiver so that the command for the operation can be send. This control unit controls the movement of the system. It includes the forward and backward direction operation. so this system does not control any other part of system hence it give limited and specific amount of function. The second control unit controls the both robotic arm. Each robotic arm consists of the three motor which can operate in the 360 degree so that for the operation of the system this control unit will control the all the movements of this system. This control unit is also having the transmission and receiver system so that it can send information and receiver and command for the main control unit.

The third control unit is mainly dedicated for the function of the sensor box. It mainly controls the function of the sensor box. It will provide the data from the sensor to the main control system. It will also have the transmission and revising transmission. Fourth controlling unit is the main controlling unit of this system .it mainly located in the hand of the operator. It can controller with the joystick and transmitter and receiver system so that it can control the motion of both internal motor system and the two robotic arm .it will also contend to the sensor box for providing information. This system also has the ultra meter display system so that it can indicate the ultra meter index for the observation of the system.

## 5. CONTROLING UNIT

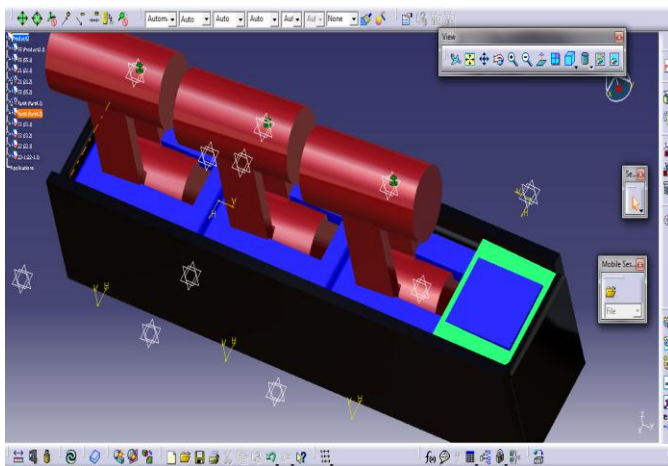

Fig 13- Controlling unit for Robot

This controlling unit control all the movements of the system. It mainly connected with the three transmission and receiver so that it can communicate with the system. It has the three joystick which can control the motion of the system.

The first joystick mainly control the forward and backward moment of the system .the second joystick control the motion of the robotic arm so that it can observe the power cable and perform the all dynamic conditions. This system is also provide with the display system so that the ultra meter index of the power cable can be observe so the net amount of heat in power cable can be measure.

## 6. ADVANTAGES

This system is compact and has the higher dynamic mobility. This system is providing with the multiple robotic system so that it can observe the power cable closely. it also has the separate control system so that it can operate system in very safe manner. Due to it less weight and higher efficacy it can be operate in any condition. Hence it has the higher operation capability.

## 7. CONCLUSION

For the preventive maintenance of the power cable this system can be use. Due to multiple element system and the number of sensor place in the system this robot can observe various parameter of the system. This system has the more dynamic stability condition due to its small and compact structure .hence system has the greater role in the preventive maintenance.

## ACKNOWLEDGEMENT

This work has been supported by Principal and Head of Department, Electrical engineering, Matoshri college of Engineering. We would also like to thank project coordinator Mr.S.S. Khule Professor Matoshri college of Engineering, for their immense support. Finally, we would like to thank our parents and peers for providing the necessary inputs for the successful completion of this paper.

## REFERENCES

- [1] R. Ishino and F. Tsutsumi, "Detection System of Damaged Cables Using Video Obtained from an Aerial Inspection of TransmissionLines", IEEE Power Engineering Society General Meeting, 2, 2004, pp.1857-1862.
- [2] S. Fu et al., "Structured-Constrained Obstacles Recognition for Power Transmission Line Inspection Robot", Proc. IEEE/RSJ Int'l Conference on Intelligent Robots and Systems, Beijing, China, 2006, pp. 3363-3368.
- [3] I. Golightly and D. Jones, "Visual control of an unmanned aerial vehicle for power line inspection", Proc. IEEE Int'l Conference on Advanced Robotics, 2005, pp. 288-295.
- [4] J. Snell and J. Renowden, "Improving results of thermographic inspections of electrical transmission and distribution lines", Proc. IEEE 9th Int'l Conf. on Transmission and Distribution Construction, Operation and Live-Line Maintenance, 2000, pp. 135-144

## BIOGRAPHIES



**Prashis S .Arkharao**

M.E power system Engineering  
Matoshri college of Engineering,  
Nashik.



**Mr.S .S Khule**

HOD Electrical Engineering  
Matoshri college of Engineering  
Nashik.