

## Smart Glove

Anakha L V<sup>1</sup>, Lavina S Vijay<sup>2</sup>, Parvathy Ajayan<sup>3</sup>, Souparnika V M<sup>4</sup>,

Ms. Manju Sreekumar<sup>5</sup> (Asst. Prof)

<sup>1-4</sup>Department of Electrical and Electronics Engineering, Mar Baselios College of Engineering and Technology, Thiruvananthapuram, Kerala, India

\*\*\*

**Abstract** - Communication with mute people is a tedious task if you are not familiar with the sign language. One of the most difficult aspects of visual impairment is the lack of orientation in unknown environments, both outdoor and indoor, resulting in dependency on sighted individuals for navigation. Smart Glove is introduced as a solution to these problems. The system mainly consists of Arduino Uno Board, Ultrasonic Sensor, Flex Sensors, Bluetooth Module, Accelerometer, GPS Module and GSM Module. The ultrasonic sensor detects the obstacles by sending and receiving signals. The flex sensors and accelerometer is used to sense hand movements. These signals are fed into a microcontroller unit which has internal ADCs which converts the analogue data to digital form speech signal and can be heard through speaker. GPS and GSM modules are used to provide the location of the person that helps them to send alarm in case of an emergency.

**Key Words:** Flex sensor, Ultrasonic sensor, GPS and GSM module, Bluetooth module, Temperature sensor.

### 1. INTRODUCTION

Speech is one of the most beautiful way of communication with people around you. Speaking is an act of making vocal sounds. We can say that speaking means to converse, or expressing one's thoughts and feeling in spoken language. To speak often implies conveying information. It may be from an informal remark to a scholarly presentation to a formal address. A kind word from someone close can console a depressed mind brilliantly. Communication is a very important thing. Speech impaired people use sign language for their communication. Most people will not be able to understand it. So a system to convert this sign language to speech is needed. For helping the speech impaired people optical flow method can be introduced [1]. Other method that can be adopted is a system comprising of sensors and Bluetooth modules. Using flex sensors for converting the sign language to speech that can be heard using Bluetooth system [2]. Sign language is converted to speech signals based on their bend resistance of flex sensors given accordingly to different signs.

Similar to speech vision or the faculty of sight is also a beautiful gift that we enjoy. More than enjoying the view the thing that affects them is their difficulties during transportation. Most visually impaired people find their

own conscience adaptable to their surroundings and will get more addressable to each and every obstacle in their path of movement. But when exposed to new and strange environment they again find it difficult to find obstacles in front of them. Eye can be said to be a person's great gift from god. However, people with visual impairment will be better in their hearing skills. Thus, system adaptable for their easy navigation is a great asset to them. Walking with the aid of cane can be replaced in those scenarios through adoption of appropriate technologies. Helping visually impaired by proposing a system that is used to detect solid as well as liquid obstacles can be adopted [3]. Use of an ultrasonic sensor and an accelerometer can assist visually impaired people's navigation [4]. In the glove ultrasonic sensor is kept for locating any type of obstacles on the path of movement. Hence, we can assure easy navigation for visually impaired people.

Security is one of the main concern of the present day. Security not only from the rising crime but also from the day-to-day accidents. In this present world of technological advancement, proper measure should be taken to maintain the security and the comfort of homes, banks and offices. By using proper security systems billions of rupees spent on departments like fire brigade, police, etc. can be brought in control. This idea of securing ourselves with the help of technology can be used. A temperature sensor is also provided in the system.

From studying the merits and demerits of different system a new implemented version capable of future expansion is made. This system is made both user and environment friendly.

### 2. PROPOSED SYSTEM

Our system consists of three parts.

1. GSM based alert system: This unit consist of a GSM module and a push button. This is used in a safety aspect.

2. Sign language translation unit: This unit consist of 5 flex sensors (resistance measurement) and an accelerometer which helps in sign language interpretation. They are placed on the gloves worn by the person. Based on the gestures the resistance values of the flex sensors changes and thus corresponding sound signals are heard through a speaker connected to it. These audio files are saved in a SD card module.

3. Ultrasonic based navigation unit: This unit consist of an ultrasonic sensor and a buzzer: On recognizing an obstacle using Doppler method the alert signal is given to the buzzer, which in turn produce a beep sound.

Here we have illustrated the general block diagram of our system.

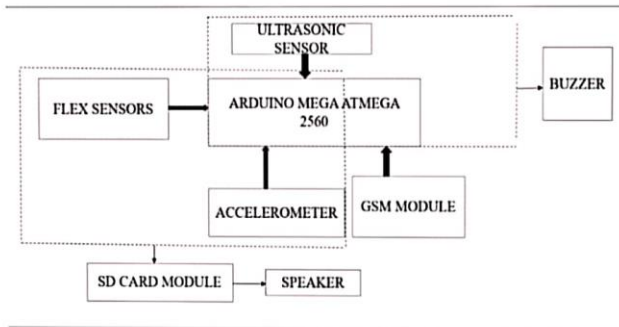

Fig -2.1: Block diagram of our system.

Arduino At-mega microcontroller is the heart of our system. It contains several analog as well as digital pins to which all the connections are made. The program of each unit of our system is written separately and then combined and uploaded in this Arduino board using Arduino IDE software.

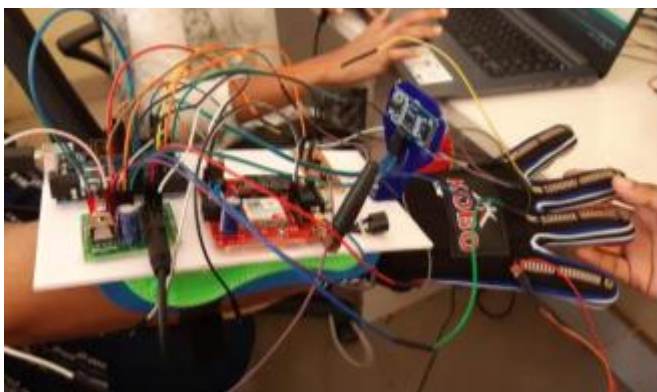

Fig -3.2: Smart glove

### 3. WORKING

As we have said earlier our system have mainly consist of three parts and work separately as individual units, together integrated to form a single system.

#### 1. Sign language translation:

The sign language translator helps in easy communication with speech impaired people. The system consists of flex sensors and accelerometer. Flex sensor is a resistance sensor which converts the change in bent to electrical resistance. The resistance value is proportional to bend radius. And an Accelerometer system is used here as a tilt sensor, which checks the titling of the hand. The basic function of this module is to recognize the tilting of hand and correspondingly sent data to At-mega microcontroller. The output obtained from accelerometers after

amplification, is an analog output which is converted to digital. The signal is then compared with the values defined in the program. The output is then amplified and corresponding sound signal is heard through a speaker.

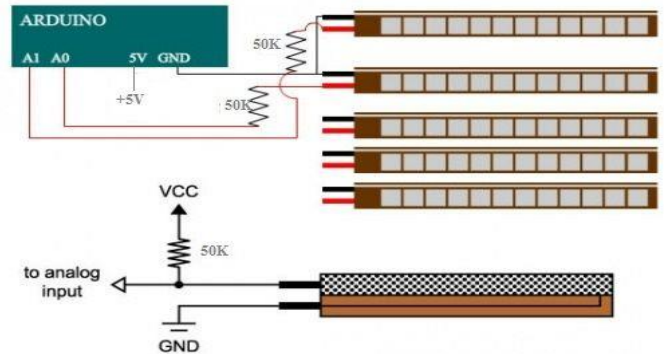

Fig -3.1: Flex sensor connection with Arduino.

#### 2. Ultrasonic sensor based navigation:

The Ultrasonic Sensor sends out a high-frequency sound pulse and then calculate the time taken for the echo of the sound to reflect back. Sound travels at an approximate speed of 340 meters per second. This corresponds to about 29.412µs per centimeter.

$$\text{Distance} = (\text{time} \times \text{speed of sound}) / 2$$

The distance of the object is measured using ultrasonic sensor and the sensor output is connected to signal conditioning unit and after which it is processed with the help of Arduino microcontroller. The measured results are subsequently displayed in a liquid crystal display. The Arduino is pre- programmed accordingly such as to produce an alert sound by the buzzer within a range of distance. Thus the person can avoid the obstacles. A switch is also included in the system, can be operated by the person in order to control the operation of the sensor.

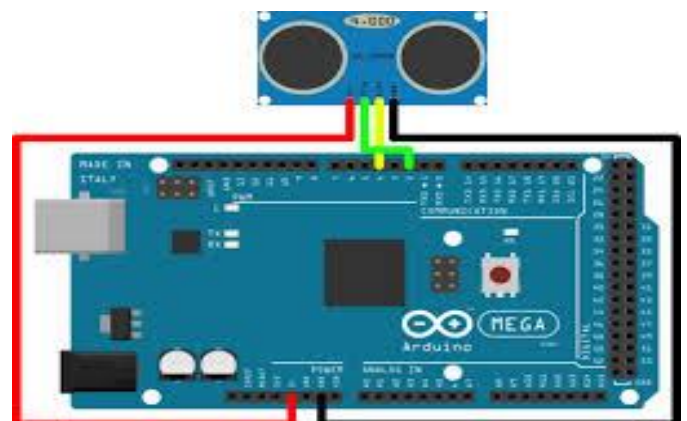

Fig -3.2: Flex sensor connection with Arduino.



### 3. GSM based alert system:

GSM based alert system helps the person to communicate via message or missed call with his/her family member under any emergency situation. The system uses SIM800A GSM module which consists of antenna, sim socket, transmitter pin, receiver pin, power supply port etc. It uses UART protocol to communicate with an Arduino. A push button is used to activate this module by the person in some emergency condition. On activation a need help message will be sent to the phone number of his or her family. Basically this system is to ensure safety of the person.



**Fig -3.3:** GSM module connection with Arduino.

We have incorporated a temperature sensor in addition to this for the measurement of body temperature.

### 4. Temperature sensor:

It is used to measure temperature in the range of -67°F to +257°F or -55°C to +125°C with ±5% accuracy. The range of received data from one wire can range from 9-bit to 12-bit. Because, this sensor follows the single wire protocol, and hence the sensor can be controlled through a single pin of microcontroller. This is an advanced level protocol, where each sensor can be set with a 64-bit serial code which helps in the control of numerous sensors using a single pin of the microcontroller. This sensor is connected to the Arduino Mega. The measured value of the temperature is displayed on LCD in Fahrenheit scale. Liquid crystal i2c display is used as LCD. The 16\*2 LCD used in this system has a total of 16 pins. Arduino is programmed such that the first row of LCD prints "Fahrenheit" and measured value is printed in the second row.

## 4. OUTPUT OBTAINED

a) Output from sign language translator:

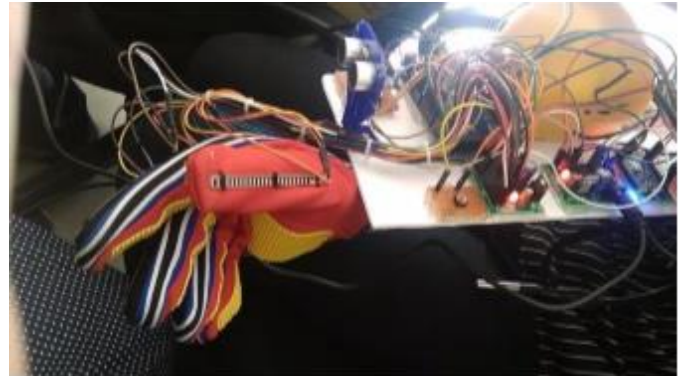

**Fig -4.1:** Showing gesture for the word 'GIVE'



**Fig -4.2:** Output is displayed on the LCD screen.

b) Output from GSM module.



**Fig -4.3:** Activating the push button.



**Fig -4.4:** A need help message is sent to the concerned mobile number in case of emergency. (after pressing the push button)



**Fig -4.5:** Need help message received.

c) Output from the temperature sensor.



**Fig -4.7:** Person holding the temperature sensor knob.



**Fig -4.8:** Output of the temperature sensor displayed on the LCD screen.

## 5. CONCLUSIONS

A multi-purpose assistive system is implemented through this project. From the basic properties of technological aspects, so many problems are attempted to be rectified. In case of visually, verbally impaired people their problem is understood and this project is made accordingly for their enhancement.

Communication problem faced by speech impaired and easy navigation of visually impaired people is achieved here through Arduino mega. GSM technology for ensuring their safety. An added feature of Temperature sensor is also been added.

It is also made in a way for any future expansion. Sign language conversion using flex sensors, Easy navigation of blind using ultrasonic based navigation system, GSM based alert safety system, Temperature sensor unit are the assistive technologies here. All these units' combinable work as a multipurpose assistive technology system. It is both user and environment friendly which improves the system to a whole new level.



**Fig -4.6:** Activating the temperature sensor.

## ACKNOWLEDGEMENT

We would like to express our gratefulness to our project supervisor Ms. Manju Sreekumar who has always been there to guide us in carrying out this project. She has always supported us with her educative guidance and her readiness to help us at any times has been a great source of motivation for us. We would also like to give our sincere thanks to Dr. Shalu George and all other faculty members who have been a great hand of help without whom it would have been difficult to complete our project work. Also articles, journals and books from online and offline sources helped us a lot in carrying out our project work. At last it would have never been possible to concentrate and work on this project without the blessings of our parents and the Almighty.

## REFERENCES

- [1] M. King, B. Zhu, and S. Tang, "Optimal path planning," *Mobile Robots*, vol. 8, no. 2, pp. 520-531, March 2001.
- [2] M. Young, *The Technical Writer's Handbook*. Mill Valley, CA: University Science, 1989.
- [3] H. Simpson, *Dumb Robots*, 3rd ed., Springfield: UOS Press, 2004, pp.6-9.
- [4] K. Elissa, "Title of paper if known," unpublished.
- [5] M. King and B. Zhu, "Gaming strategies," in *Path Planning to the West*, vol. II, S. Tang and M. King, Eds. Xian: Jiaoda Press, 1998, pp. 158-176.
- [6] B. Simpson, et al, "Title of paper goes here if known," unpublished.
- [7] J.-G. Lu, "Title of paper with only the first word capitalized," *J. Name Stand. Abbrev.*, in press
- [8] Y. Yorozu, M. Hirano, K. Oka, and Y. Tagawa, "Electron spectroscopy studies on magneto-optical media and plastic substrate interface," *IEEE Translated J. Magn. Japan*, vol. 2, pp. 740-741, August 1987 [Digest 9th Annual Conf. Magnetics Japan, p. 301, 1982].
- [9] M. Young, *The Technical Writer's Handbook*, Mill Valley, CA: University Science, 1989.