

A Survey on Indoor Positioning System

Akshata Madguni¹, Niketan Doddamani², Harish Kalwad³, Harsha Shinde⁴, Prashant Achari⁵

¹UG-Student, Dept. of Electronics and Communication KLE Technological University Hubballi, India

²UG-Student, Dept. of Computer Science KLE Technological University Hubballi, India

³UG-Student Dept. of Electronics and Communication KLE Technological University Hubballi, India

⁴UG-Student Dept. of Electronics and Communication KLE Technological University Hubballi, India

⁵Asst Prof Dept. of Electronics and Communication KLE Technological University Hubballi, India

Abstract - The global positioning system is playing a major role in our day-to-day lives. All smartphones today have GPS, which has made our lives simple. We can easily track a vehicle or find the route to an unknown place at our fingertips. We can also share our live locations. Besides all these applications, GPS fails when it comes to indoor. GPS is a network of satellites and it finds the location by calculating its distance from three or more satellites, based on the signals received. When we try to use GPS indoor, the signals will be scattered by the walls and roof of the building and get attenuated. The distance calculated from the attenuated signals won't be accurate which makes GPS not suitable to use indoor.

There are many situations where we need indoor tracking. We often face the difficulty in finding some important things kept inside the building and waste our time in searching the same. Sometimes, we may also need to keep the track of the time spent by people in a particular place. Such problems can be addressed using indoor asset tracking and management.

Key Words: IPS, RSSI, BLE, Wi-Fi, RFID, UWB, TOA, AP, RP.

1. INTRODUCTION

Indoor positioning system is used to locate indoor asset where GPS lacks precision, and also cannot penetrate through concrete. It has wide variety of applications in commercial, military, retail, and inventory tracking industries. Radio waves, light etc. are used in finding the location. The main objective of this paper is to discuss about the various modules and techniques through which indoor positioning can be achieved. The pros and cons of each technique is discussed and are compared so that the best module appropriate to a particular project can be chosen. Various techniques discussed below are: Trilateration, Triangulation, Fingerprint pattern matching, Earth's Magnetic Field. Further these techniques can be used individually or can be combined to obtain better results. These techniques use RSSI as the main input from the transmitter and process them using mainly time of arrival to calculate distance between transmitter and receiver. These techniques can be extended to different modules such as: BLE (Bluetooth Low Energy devices) module, Wi-Fi module, RD ID (Radio Frequency ID), UWB module (Ultra-wide band technology). Based on requirement of precision respective module and techniques are selected.

2. METHODS USED TO ESTIMATE THE LOCATION

The indoor positioning can be achieved through many modules like BLE beacons, Wi-Fi technology, Ultra-wide band, RF ID. Each of the modules has its own pros and cons.

Methods used to estimate the location:

- i. Trilateration
- ii. Triangulation
- iii. Fingerprint Pattern Matching
- iv. Earth's Magnetic Field

Using RSSI (Received Signal Strength Indication) and MAC address (Media Access Control), the current location of the end user device can be calculated.

2.1 Trilateration

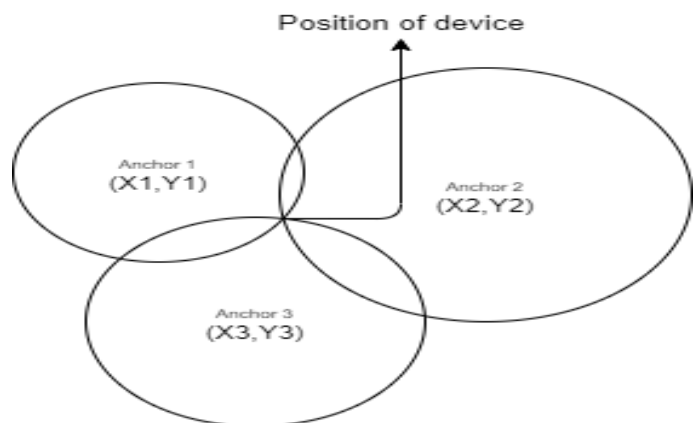

Fig -1: Trilateration

It is a method which requires at least three RSSI values of the signal transmitted from a particular beacon, received by three different anchors. Before installing the anchors, we should have floor map with the dimensions and the coordinates, and anchors must be placed strategically so as to cover maximum area of the room. Based on the RSSI values, three distances of the beacon from each anchor is calculated using the formula,

$$\text{Distance} = 10^{\frac{(\text{Measured Power} - \text{RSSI})}{10 \cdot N}}$$

Measured Power = RSSI measured at a distance of 1m
RSSI = received RSSI

N = constant depending on environment
 N ranges from 2-4.

Knowing the three anchor's coordinates and the distance of beacon from them, we get three simultaneous equations. Solving them yields us beacon coordinates. The advantages of using this technique is that no huge data set is needed and registering a new anchor is easy since only its coordinates are to be noted. The disadvantage is that care should be taken that there exists a clear line of sight between beacon and anchor at every part of the building so that the signal won't be attenuated by walls or any other obstacles.

2.2 Triangulation

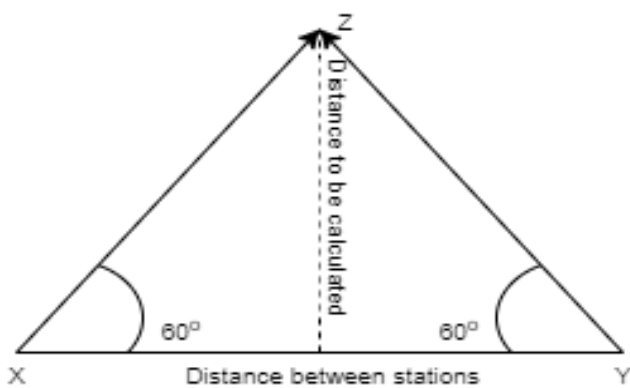

Fig -2: Triangulation

It is another method where location is calculated based on the distance between two anchors and the angle at which the signals are transmitted. The placed stations start emitting the signal. The signal's after hitting the object rebounds to the initial station. Further based on time of arrival (TOA), we can calculate distance.

$$\text{Distance} = \text{Speed of light} * \text{TOA}$$

Similarly, the other station works and finds the distance of the object from it. Hence approximate location of the object is determined which is the intersecting point of the signal's emitted by both stations. Huge data set is not needed for this technique, but getting the angle of transmission is tedious.

2.3 Fingerprint Pattern Matching

It is a technique which consists of AP (access points) and RP (reference points). Access points are fixed networking device to which a Wi-Fi enabled device can connect. Fingerprint technology is based on the relationship between the given location and the corresponding radio signature, i.e. the signal strengths collected from all the surrounding access points. It has two phase, calibration phase and online phase. In calibration phase, first we create a map for the required area of the building. The access points are spread all over the area at regular intervals to cover the entire area. Reference points

(RPs) are chosen such that the entire area is covered. The signal strengths from all the APs to a particular RP is collected and stored in a database. This is called fingerprint of that location. The signal strength from the nearest AP will be strongest and the farthest AP will be weakest. Since the RSSI values vary frequently, the mean of the RSSI can be taken or filters like Kalman filter can be used. So, each RP will have the mean of signal strengths from all APs. The database will also include the location of the APs and the RPs along with the signal strengths.

In online phase, we use the fingerprint collected to locate a device in unknown location. A Wi-Fi enabled device receives signals from the nearest APs, which is compared with the signal strengths stored in the database and the location of the device is determined. The advantage of this technique is that it has high accuracy and can cope up with non-line of sight. The major disadvantage is that it needs a huge data set which consumes lot of time and labor in collecting the data set. It is also expensive.

2.4 The Earth's magnetic field

It is spatially characterized by direction and intensity. This property can be used for indoor tracking. It has two phases, training and positioning. In training phase, the earth's magnetic field at every reference point is recorded and stored in the data set. When positioning, the magnetic field measurements are taken and compared with the data set to get the location. Indoor positioning using magnetic field is an interesting topic, but it is required that the earth's magnetic field should be stable.

3. MODULES

Different modules that can be used are:

- i. BLE module-Bluetooth Low Energy devices
- ii. Wi-Fi module
- iii. RFID module-Radio Frequency Identification
- iv. UWB module-Ultra-wide band

Further the techniques used in distance calculation and prediction of the position of the asset can be extended on different modules, be it individual technique or we can combine techniques to get better results

3.1 BLE module

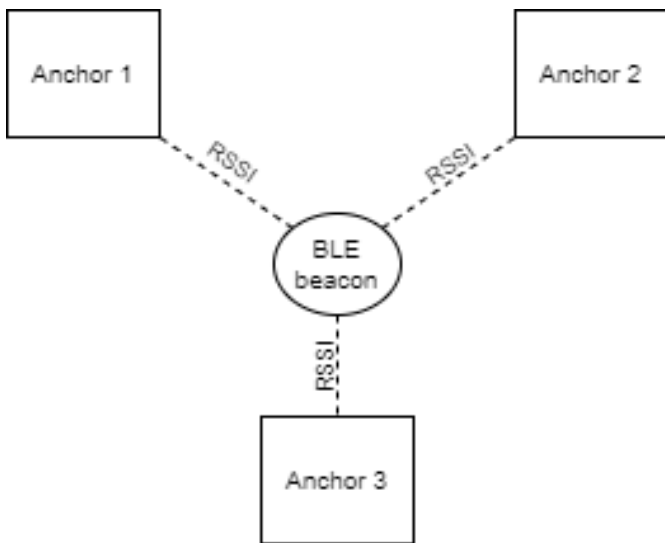

Fig -3: BLE module

In the above figure anchor refers to BLE-WIFI gateway and BLE refers to Bluetooth low energy. Here BLE devices are referred as beacons. Beacons are small, inexpensive BLE (Bluetooth Low Energy) signal transmitters that send out signals radially of about 10-30 meters (interior spaces). BLE signals contain UUID (Universally Unique Identifier), Major ID (which indicates a particular subset of beacons), and Minor ID (which is unique to each beacon). The asset to be tracked, should have this beacon associated with it, which transmits its identity continuously. The gateways(anchors) should be placed specifically inside the room to receive the signals transmitted by the nearby beacons. These signals are further sent to the back end through Wi-Fi which finds the distance of the asset from the reference anchor based on the RSSI value and the coordinates of the reference anchor. The signals from at least three anchors should be received and by calculating their respective distances to the asset to be tracked, the location of the asset can be determined using trilateration. Some of the advantages of using BLE beacons are, they are cost-effective and can be installed with minimal effort and also determines position accurately up to one meter. They are compatible with Android and iOS. There are also some limitations which include, shorter range, signals may get reflected or absorbed, which may make the received data to be inaccurate. It has shorter battery life and may sometimes have delay in detecting the object.

The anchors should be installed appropriately inside a room in-order to get the accurate location. Some of the strategies that can be used are, they should be placed such that no area is left uncovered, and should also be placed at-least at three meters high to get a clear line of sight. They should be placed such that any 3 anchors taken at a time, form a triangle i.e. we must ensure that each point within the room to be monitored is ideally covered by three beacon signals. Three nearby anchors considered, should have overlapping areas

to improve accuracy. One of the ways is to divide the floor into regular hexagons and placing a beacon at the center of each. Placing the anchors in co-linear, maximizes the error in position determined.

3.2 Wi-Fi module

The use of Wi-Fi to estimate location is good approach, since Wi-Fi access points are readily available in indoor environment.

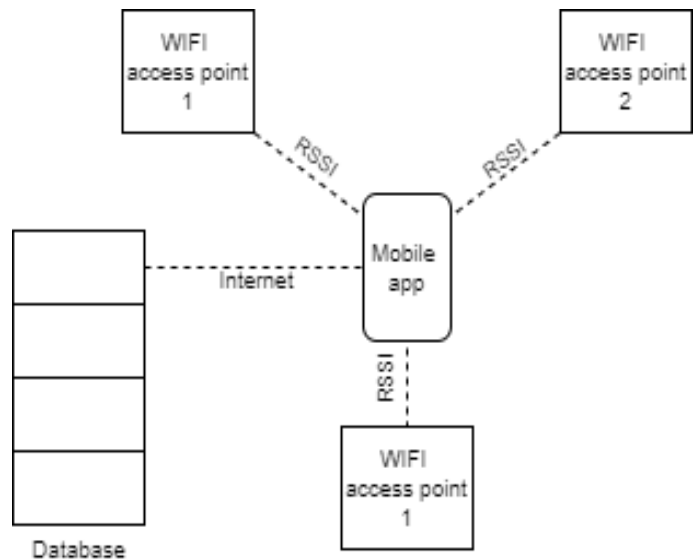

Fig -3: Wi-Fi module

Using a RSSI (Received Signal Strength Indication) and MAC address (Media Access Control), an app can calculate the current location of the end user device.

3.2.1 Main features of WIFI module

- It covers range up-to 150m.
- Accuracy is about 2-5m.
- Selection of different Paths.
- Client-based positioning is not possible with iOS devices.

3.3 RFID module

The third technology that can be used is RFID (radio-frequency identification), which uses radio waves to transmit the identity. The assets should have an RFID tag which may be either active or passive tags. The passive tags are energized by the RFID readers, when they come in the vicinity of reader. The readers get the information from the tag and send them to the host for processing. Whereas, active tags will be continuously transmitting the signals, and the nearby readers receive the signals and compare the signal information with the saved data set.

3.3.1 Main features of RFID

- RFID (radio-frequency identification) uses radio waves to wirelessly transmit the identity.
- The power source for passive RFID tag is provided by reader.
- It has very high accuracy.
- It has a short range of less than 1m.

3.4 UWB module

Ultra-wide band is a short-range radio technology that can be used for indoor positioning. It uses an extremely wide frequency range with a bandwidth of at least 500 MHz. For exact localization of objects at-least three receivers are necessary. It is used in applications which demands high accuracy of 10 to 30cm. The position is determined by transmit time method (Time of flight) instead of RSSI.

3.4.1 Advantages of using ultra-wide band are

- Ultra-wide band is a short-range radio technology.
- It has a high accuracy of 10 to 30cm.
- Less to none interference with other devices.
- Not prone to multiple path propagation.
- Power efficient transceivers.
- Not prone to noise due to the nature of the signals in the form of a train of impulses.
- The position is determined by transmit time method (Time of flight) instead of RSSI.

3.4.2 Limitations of RFID

- For exact localization of objects at least 3 receivers are necessary.
- Its main limitation is that it is expensive as compared to other technologies.

4. COMPARISON OF MODULES

Table -1: Final comparison of all the modules

COMPARISON OF MODULES				
	WIFI	Bluetooth	UWB	RFID
Operating range	150m	70m	150m	1m
Mode	RSSI	RSSI	TOA	RSSI
Battery life	3 years	5-7 years	2 weeks	-
Cost	High	Low	High	High

5. REQUIREMENTS OF INDOOR POSITIONING

5.1 Technical requirements for indoor positioning

- A tag to transmit signals continuously.
- Anchors to receive signals.
- Setting up a server to analyze and log the received signals.
- Power supply

5.2 Non-technical requirements

- Dimensions of the building in which the system to be deployed.
- Number of assets to be tracked.

6. CONCLUSION

Indoor positioning can be achieved through any of the modules like BLE, RFID, UWB or Wi-Fi. Each of the modules have its own advantages and disadvantages. So, based on what application a project demands, particular module is selected. Any of the controllers like Arduino, raspberry pi, computers or laptops can be used as server to compute the data collected. Using software like node-red, data can be easily processed further. If accuracy is of higher priority, then fingerprint pattern matching technique is used to compute the location. If proximity is needed and ease of computation or ease of extending the tracking system is of higher priority, then trilateration is used. Thus, indoor assets can be easily tracked by building an efficient indoor positioning system, where GPS fails to do its work. Just as people move anywhere outdoor conveniently using GPS, they can now be provided with the same convenience of moving anywhere indoor using IPS. Apart from that, IPS also has its applications in large Warehouses, Hospitals, Retailers, Airports, Hotels etc.

REFERENCES

- [1] Townsend, K.; Davidson, R.; Cuf'1, C. Getting Started with Bluetooth Low Energy: Tools and Techniques for Low-Power Networking; O'Reilly: Sebastopol, CA, USA, 2014. M. Young, The Technical Writer's Handbook. Mill Valley, CA: University Science, 1989.
- [2] Lymberopoulos, D.; Liu, J.; Yang, X.; Choudhury, R.R.; Handziski, V.; Sen, S. A Realistic Evaluation and Comparison of Indoor Location Technologies: Experiences and Lessons Learned. In Proceedings of the 14th International Conference on Information Processing in Sensor Networks, Seattle, WA, USA, 13–16 April 2015; pp. 178–189.
- [3] <https://www.csd.uoc.gr/hy439/papers/gu2009pdf.pdf>
- [4] www.academia.edu/download/31555342/Survey_of_Wireless-Indoor-Positioning1.pdf

- [5] http://www.academia.edu/download/33814983/A-Survey_of-Indoor-Positioning-and-Object-Locating-Systems.pdf
- [6] Liu, H.; Gan, Y.; Yang, J.; Sidhom, S.; Wang, Y.; Chen, Y.; Ye, F. Push the Limit of WIFI Based Localization for Smartphones. In Proceedings of the 18th Annual International Conference on Mobile Computing and Networking, Istanbul, Turkey, 22–26 August 2012; pp. 305–316.
- [7] <https://www.talentica.com/assets/white-papers/wifi-indoor-positioningusing-smartphones.pdf>Societies (INFOCOM 2000), Tel Aviv, Israel, 26–30 March 2000; pp. 775–784.
- [8] Bor, M. Indoor Localization for Wireless Sensor Networks. Master's Thesis, Embedded Software Group, Delft University of Technology Delft, Delft, The Netherlands, 2009.