

# FLEXURAL BEHAVIOUR OF REINFORCED CFRP EMBEDDED HOLLOW CORE BEAM

Swaja Kommaleri Manayel<sup>1</sup>, Er Ajesh K Kottuppillil<sup>2</sup>

<sup>1</sup>PG Scholar, Department of civil engineering, SAINTGITS College of engineering, Kerala, India

<sup>2</sup>Assistant Professor, Dept. of Civil Engineering, SAINTGITS College of engineering, Kerala, India

\*\*\*

**Abstract** - Concrete materials are dominant material used for construction due to its advantages such as workability, low cost and fire resistance as well as its low maintenance cost. Nowadays research efforts are continuously looking for new, better and efficient construction material and method. This study focuses on optimization of structural material by introducing hollow core in RC beams. By material optimization, we can reduce the dead loads which contribute to seismic effect in high rise structures. As concrete is weak in taking tension, steel reinforcements are provided in this zone. The concrete below the neutral axis act as a stress transfer medium between the compression and tension zone. However, in RC beams strength of concrete lying in and near the neutral axis is not fully utilized. This un-utilized concrete is removed by replacing with any lightweight material Here, CFRP tubes are wrapped in the inner wall of the hollow core. The study is done to know the flexure behavior of hollow core RC beam by using the software ANSYS 16.0. The flexural behavior of hollow core RC beam with and without CFRP, with varying percentages of concrete replacement and different l/d ratios are compared by giving two-point loading. It can be concluded that hollow core beams with CFRP lining shows better performance than without CFRP. It is also concluded that as l/d ratio decreases deflection decreases and beams from which lesser percentage of concrete is replaced shows better performance

taking up tension, steel reinforcements are provided at the tension zone of the beam.

There are methods for increasing the effectiveness of concrete below neutral axis such as prestressing and converting the beam into other shapes such as Tee beams. But these methods cause change in the geometry of the structure and increases the construction cost. However, in RC beams strength of concrete lying in and near the neutral axis is not fully utilized. This un-utilized concrete is removed by replacing with any lightweight. This can also be done by partially replacing the concrete below neutral axis by air voids i.e., by providing hollow cores in the RC beams. The inner wall of the hollow core is wrapped with Carbon Fibre Reinforced Polymer (CFRP). Fibre reinforced polymer is a composite material made of a polymer matrix reinforced with fibers. FRP is used as a widespread technique in concrete retrofitting. CFRP is cost-effective in several field applications strengthening concrete, masonry, steel, cast iron, and timber structures. Many studies have shown that it has a large impact on strength but moderate increase in stiffness. It enhances shear strength of reinforced concrete.

## 2. OBJECTIVE

The following are the objectives: -

- Validation using ANSYS
- To Compare the flexural behaviour of reinforced hollow concrete beams with and without CFRP
- To Compare the flexural behavior of hollow core beams with different percentage of replacement of concrete
- To compare the flexural behavior of hollow core beam with different l/d ratio.

## 3. SCOPE

The scope of the study is: -

- Here the inner wall of the hollow core of the RC beam is wrapped with CFRP.

**Key Words:** Hollow core beam, flexural behaviour, CFRP,

## 1. INTRODUCTION

Nowadays research efforts are continuously looking for new, better and efficient construction material and method as massive exploration of the natural resources for producing concrete affect to the environment condition and global warming. We have responsibility to reduce the effect of the application of concrete materials to environmental impact. The concrete should be used as efficiently as much as possible. Structural material optimization by introducing hollow core in RC beams can be done. By material optimization, we can reduce the dead loads which contribute to seismic effect in high rise structures. In case of normal simply supported reinforced concrete beam, the neutral axis divides the tension zone and compression zone. The region below the neutral axis is in tension and the region above neutral axis is in compression. Since concrete is weak in

- This is limited to beams

This can increase the strength of the beams.

#### 4. PROPOSED WORK

For the analysis the specimens are grouped into three groups Beam A, Beam B and Beam C, each group consisting of 4 beam specimens of M30 grade concrete and Fe500 steel. The three group differ from each other in their depth. The length and breadth of these 12 specimens are the same and they are 2100mm and 200mm respectively. The reinforcement given to the specimens are 3 bars of 16mm diameter at bottom, 2 bars of 12mm diameter at top and 8mm diameter stirrups. A clear cover of 12mm and an effective cover of 20mm are given to all specimens. The three group of specimens are as follows,

**BEAM A:** This is the first group of specimens having a depth, D of 220mm and effective depth, d of 200mm Beam A is of 4 types:

Beam A1- Beam with CFRP embedded hollow core in which 7.66% of concrete is replaced by hollow core below neutral axis.

Beam A2- Beam with hollow core without CFRP in which 7.66% of concrete is replaced by hollow core below neutral axis.

Beam A3- Beam with hollow core in which 5.66% of concrete is replaced by hollow core below neutral axis.

Beam A4- Beam with hollow core in which 3.66% of concrete is replaced by hollow core below neutral axis.

**BEAM B:** This is the first group of specimens having a depth, D of 270mm and effective depth, d of 250mm Beam B is of 4 types:

Beam B1- Beam with CFRP embedded hollow core in which 15.02% of concrete is replaced by hollowcore below neutral axis.

Beam B2- Beam with hollow core without CFRP in which 15.02% of concrete is replaced by hollow core below neutral axis.

Beam B3- Beam with hollow core in which 13.02% of concrete is replaced by hollow core below neutral axis.

Beam B4- Beam with hollow core in which 11.02% of concrete is replaced by hollow core below neutral axis.

**BEAM C:** This is the first group of specimens having a depth, D of 320mm and effective depth, d of 300mm Beam C is of 4 types:

Beam C1- Beam with CFRP embedded hollow core in which 23.33% of concrete is replaced by hollowcore below neutral axis.

Beam C2- Beam with hollow core without CFRP in which 23.33% of concrete is replaced by hollow core below neutral axis.

Beam C3- Beam with hollow core in which 21.33% of concrete is replaced by hollow core below neutral axis.

Beam C4- Beam with hollow core in which 19.33% of concrete is replaced by hollow core below neutral axis.

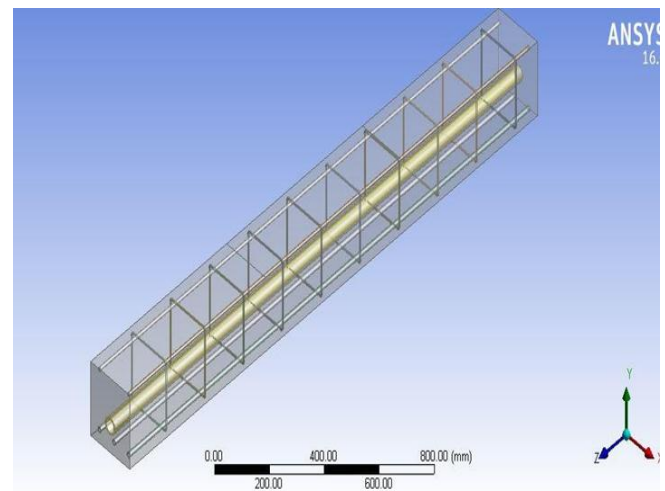

**Fig -1:** Model of a CFRP embedded hollow core beam

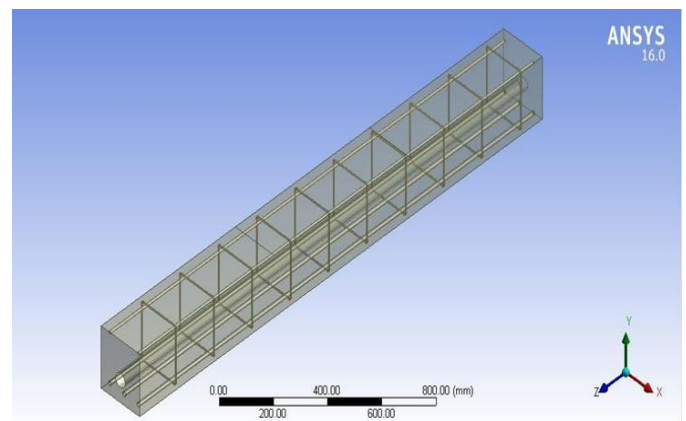

**Fig -2:** Model of a hollow core beam without CFRP

Meshing is defined as the process of dividing the whole structure into a number of elements so that whenever the load is applied on the component it distributes the load uniformly. After meshing, the entire structure is divided into a number of elements and each element have its own stiffness while loading.

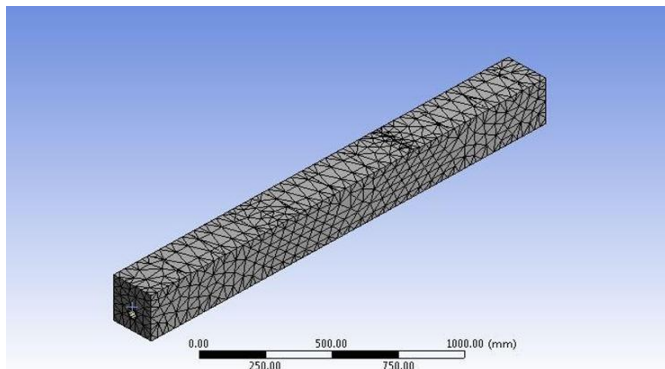

Fig -3: Meshing diagram of the specimen

Loading is given to the specimens during the analysis is shown in the fig 4. Here two-point loading is given at L/3 distance from both the ends of the specimen.

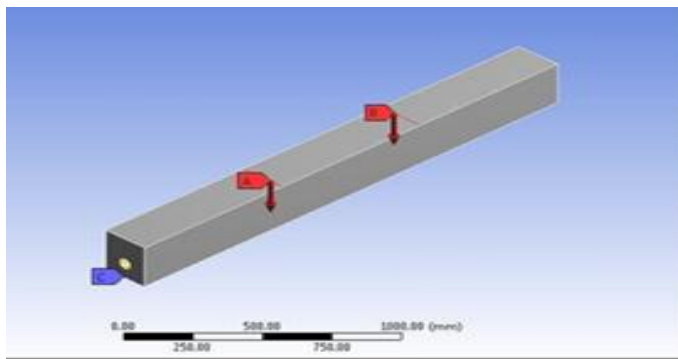

Fig -4: Loading diagram of the specimen

## 5. RESULTS AND DISCUSSIONS

### 5.1 Load v/s deflection graph

#### Hollow core beam specimens with different l/d ratios

The load values and corresponding deflection of the hollow core beam specimens with different l/d ratios are shown in the table 1.

The load v/s deflection graph of the hollow core beam specimens with different l/d ratios is shown in chart 1. To compare the flexural behavior of hollow core beam specimens with different l/d ratios beam A2, beam B2 and C2 are chosen as these are the beams in which maximum possible amount of concrete is replaced keeping minimum cover distances at both sides of the hollow core beam below the neutral axis. specimen C2 shows better performance and as the l/d ratio decreases deflection values also decreases.

Table -1: Load values and corresponding deflection of the hollow core beam specimens with different l/d ratios

Load	Deflection values		
	A2	B2	C2
25	0.74462	0.44846	0.29581
50	1.4892	0.89692	0.59162
75	2.2338	1.3454	0.88743
100	2.9784	1.7938	1.1832
125	3.73	2.2423	1.4791
150	4.4676	2.6907	1.7749
175	5.2122	3.1392	2.0707
200	5.9568	3.5877	2.3665
225	6.7014	4.0361	2.6623
250	7.446	4.4846	2.9581

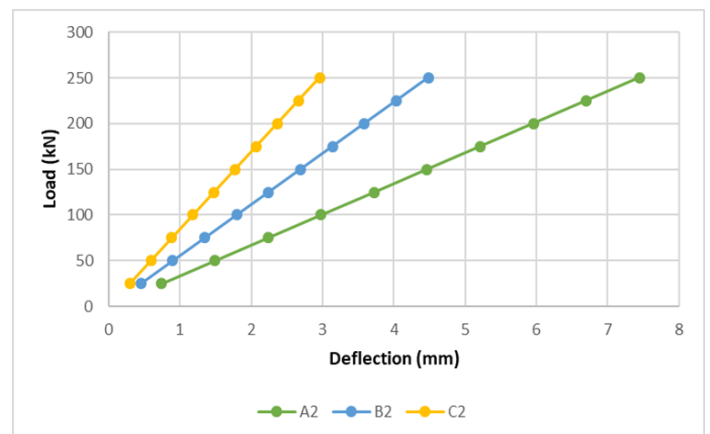

Chart -1: Load v/s deflection graph of the hollow core beam specimens with different l/d ratios

#### Hollow core beam specimens with and without CFRP

The load values and corresponding deflection of the hollow core beam specimens with and without CFRP are shown in the table 2, table 3 and table 4 for the first group specimens, second group specimens and the third group specimens respectively. Here it is clear from the tables itself that as the load increases deflection increases.

The load v/s deflection graph of the hollow core beam specimens with and without CFRP of the first group

specimens, second group specimens and the third group specimens are shown in chart 2, 3 and 4 respectively.

To compare the flexural behavior of hollow core beam specimens with different l/d ratios beam A1 and A2, beam B1 and B2 and C1 and C2 are chosen.

**Table -2:** The load values and corresponding deflection of the hollow core beam specimens with and without CFRP for the first group specimens

Load	Deflection values	
	A1	A2
25	0.7377	0.74462
50	1.4673	1.4892
75	2.2009	2.2338
100	2.9345	2.9784
125	3.668	3.73
150	4.4016	4.4676
175	5.1352	5.2122
200	5.8687	5.9568
225	6.6023	6.7014
250	7.3359	7.446

**Table -3:** The load values and corresponding deflection of the hollow core beam specimens with and without CFRP for the second group specimens

Load	Deflection values	
	B1	B2
25	0.43519	0.44846
50	0.87037	0.89692
75	1.3055	1.3454
100	1.7407	1.7938
125	2.1759	2.2423
150	2.6111	2.6907
175	3.0462	3.1392
200	3.4814	3.5877
225	3.9166	4.0361
250	4.3518	4.4846

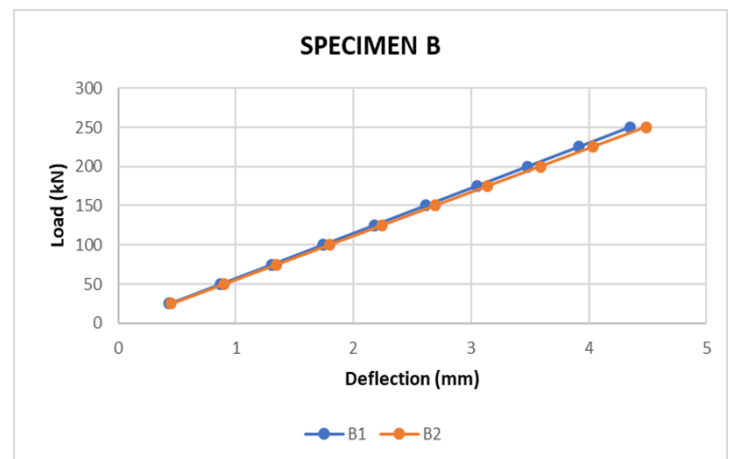
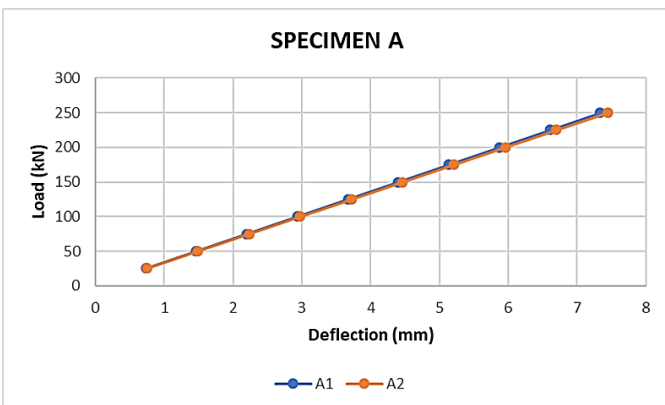
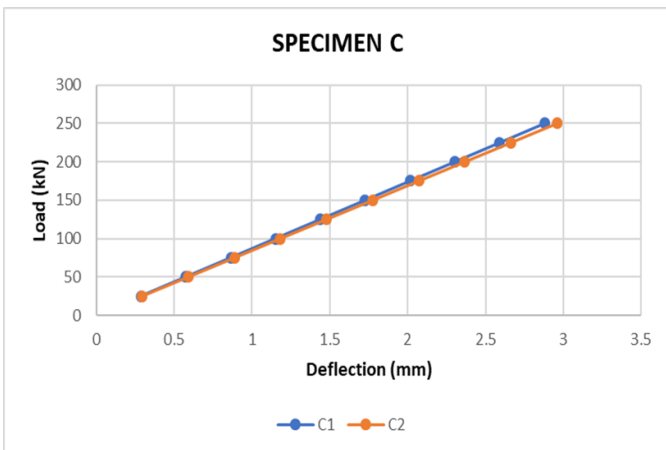

**Chart -2:** The load v/s deflection graph of the hollow core beam specimens with and without CFRP of the first group specimens

**Chart -3:** The load v/s deflection graph of the hollow core beam specimens with and without CFRP of the second group specimens

**Table -4:** The load values and corresponding deflection of the hollow core beam specimens with and without CFRP for the third group specimens

Load	Deflection values	
	C1	C2
25	0.28781	0.29581
50	0.57562	0.59162
75	0.86343	0.88743
100	1.1512	1.1832
125	1.439	1.4791
150	1.7269	1.7749
175	2.0147	2.0707
200	2.3025	2.3665
225	2.5903	2.6623
250	2.8781	2.9581



**Chart -4:** The load v/s deflection graph of the hollow core beam specimens with and without CFRP of the third group specimens

From the graphs, it is clear that, when CFRP is lined inside the hollow core, deflection has been decreased. CFRP can be used to reduce deflection of the hollow core beams irrespective of the l/ratio.

**Hollow core beam specimens with varying percentages of replaced concrete**

The load values and corresponding deflection of the hollow core beam specimens with varying percentages of replaced concrete are shown in the table 5, table 6 and table 7 for the first group specimens, second group specimens and the third group specimens respectively.

The load v/s deflection graph of the hollow core beam specimens with varying percentages of replaced concrete of the first group specimens, second group specimens and the third group specimens are shown in fig 5, fig 6 and fig 7 respectively.

**Table -5:** Load values and corresponding deflection of the hollow core beam specimens with varying percentages of replaced concrete of first group of specimens

Load	Deflection values		
	A2	A3	A4
25	0.74462	0.74141	0.73735
50	1.4892	1.4828	1.4747
75	2.2338	2.2242	2.212
100	2.9784	2.9655	2.9493
125	3.73	3.7069	3.6865
150	4.4676	4.4483	4.4238
175	5.2122	5.1896	5.1611
200	5.9568	5.931	5.8984
225	6.7014	6.6724	6.6357
250	7.446	7.4137	7.373

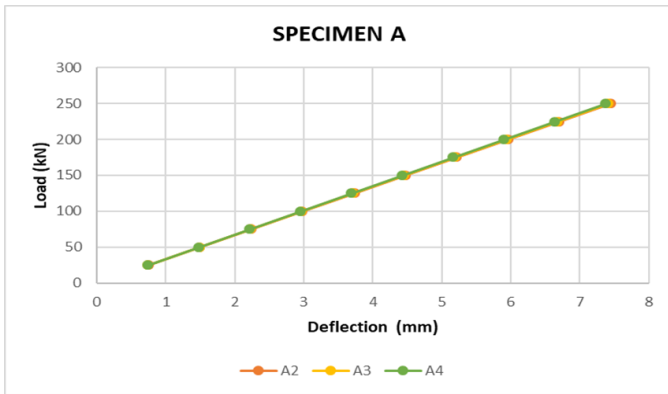

**Chart -5:** The load v/s deflection graph of the hollow core beam specimens of the first group specimens with varying percentages of the replaced concrete

**Table -6:** Load values and corresponding deflection of the hollow core beam specimens with varying percentages of replaced concrete of second group of specimens

Load (kN)	Deflection values (mm)		
	B2	B3	B4
25	0.44846	0.44237	0.4404
50	0.89692	0.88459	0.88075
75	1.3454	1.3268	1.3211
100	1.7938	1.769	1.7614
125	2.2423	2.2112	2.2018
150	2.6907	2.6534	2.6421
175	3.1392	3.0955	3.0824
200	3.5877	3.5377	3.5228
225	4.0361	3.9799	3.9631
250	4.4846	4.4221	4.4034

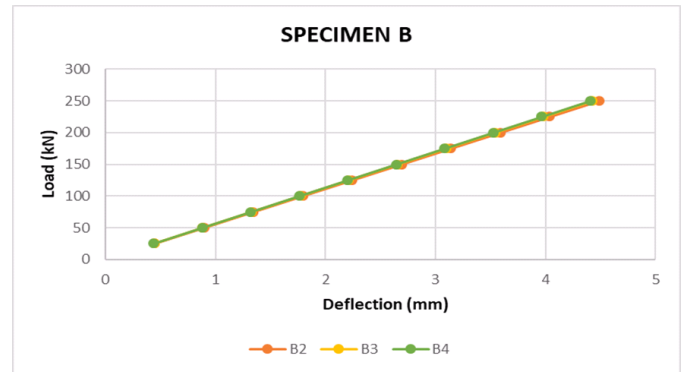

**Chart -6:** The load v/s deflection graph of the hollow core beam specimens of the second group specimens with varying percentages of the replaced concrete

**Table -7:** Load values and corresponding deflection of the hollow core beam specimens with varying percentages of replaced concrete of second group of specimens

Load	Deflection values		
	C2	C3	C4
25	0.29581	0.29315	0.29106
50	0.59162	0.5863	0.58212
75	0.88743	0.87944	0.87318
100	1.1832	1.1726	1.1642
125	1.4791	1.4657	1.4553
150	1.7749	1.7589	1.7463
175	2.0707	2.052	2.0374
200	2.3665	2.3452	2.3285
225	2.6623	2.6383	2.6195
250	2.9581	2.9315	2.9106

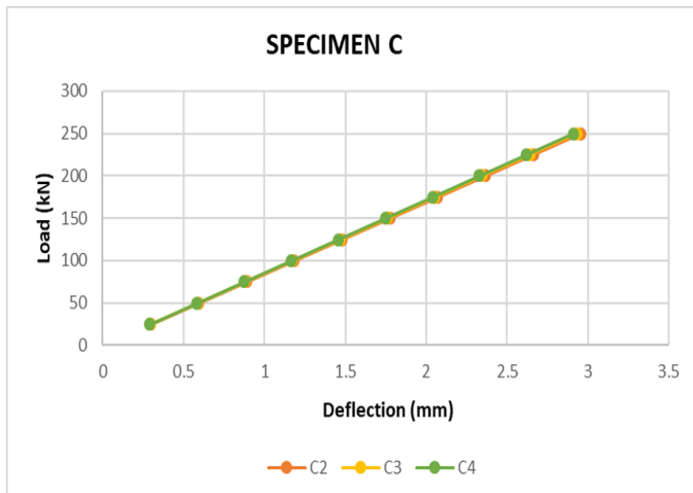

**Chart -6:** The load v/s deflection graph of the hollow core beam specimens of the third group specimens with varying percentages of the replaced concrete

From the graphs deflection of the specimen increases as the percentage of concrete replaced gets increased. More the concrete replaced; more will be the deflection.

## 6. CONCLUSIONS

The concrete below the neutral axis act as a stress transfer medium between the compression and tension zone. However, in RC beams strength of concrete lying in and near the neutral axis is not fully utilized. This un-utilized concrete is removed by replacing with any lightweight material. Here, CFRP tubes are wrapped in the inner wall of the hollow core. The study was done to know the flexure behavior of hollow core RC beam by using the software ANSYS 16.0. The flexural behavior of hollow core RC beam with and without CFRP, with varying percentages of concrete replacement and different l/d ratios were compared by giving two-point loading.

Based on the analytical study conducted on hollow core RC beams, the following conclusions were drawn,

- As the l/d ratio decreases deflection decreases and when maximum possible concrete is replaced
- CFRP embedded hollow core beam deflects less when compared to hollow core beam without CFRP with same % of concrete replaced.
- More the concrete replaced more will be the deflection irrespective of difference in l/d ratio
- Flexural behavior of hollow core beam with CFRP is better than hollow core beam without CFRP
- Flexural behavior of hollow core beam with least l/d ratio is better

- Flexural behavior of hollow core beam from which least percentage of concrete is replaced is better

## REFERENCES

- [1] M N S Hadi, H A Goaiz, T Yu, (2018), "Experimental investigation of CFRP confined hollow core reactive powder concrete columns", *Construction and Building Materials*, 174, 343-355
- [2] N Jeevan, H N J Reddy, (2017), "Comparative Study on Flexural Strengthening of RC Beams using CFRP Laminate by Different Techniques", *Materials Science and Engineering*, 225012112
- [3] Parthiban N, Dr Neelamegam M, (2017), "Flexural behavior of reinforced concrete beams with hollow core in shear section", *International Research Journal of Engineering and Technology (IRJET)*, Volume 4
- [4] Bhattarai N, Bhattarai B P, (2017), "Experimental study on flexural behavior of reinforced solid and hollow concrete beams", *International Journal of Engineering Research and Advanced Technology (IJERAT)*, Volume 3
- [5] Satheesh V.S, Nyodu B, (2017), "Flexural Behavior of Hollow RC beam using Glass Fiber", *International Journal of Science Technology & Engineering*, Volume 3
- [6] Esfahani M R, Kianoush M R, Tajari A R, (2007), "Flexural behaviour of reinforced concrete beams strengthened with CFRP sheets", *Engineering Structures*, 29, 2428-2444
- [7] Takeda K, Mitsui Y, Murakami K, (2000) "Flexural behaviour of reinforced concrete beams strengthened with carbon fibre sheets", Elsevier Science Limited, 1359- 1835