

Fault Detection in Overhead Lines using IoT

Dr. A Radhika^[1], K Sathya Kumar^[2], M Rajeshvara Boopathi^[3], K V Priyadharshan^[4]

¹Associate Professor, Electrical and Electronics Engineering, Velammal College of Engineering and Technology, Madurai, Tamil Nadu.

^{2,3,4}Student, Electrical and Electronics Engineering, Velammal College of Engineering and Technology, Madurai, Tamil Nadu.

Abstract - The fault occurred in transmission line is very much dangerous for the locality. In HV and EHV transmission line there are less fault occurrence but in locality the fault occurrence is more as compared to outer transmission line. In our prototype we design a model which is to be detect the fault in transmission line by comparing the voltage signal between the transmission line and a reference value, the reference value is predetermined and if the transmission line voltage is more than or less than reference value then fault is to be shown in display. The information regarding fault occurrence in particular phase is send to web page via IoT device which is MCU(Esp8266). Here in our project if the peak hour consumption is high, the system itself will check it and cutoff the least priority loads. The loads are assigned with static priorities, if the consumption is high, the currently running low priority load will be switched off and we can get load controlled. And following faults are reduced and the faults may include line to line fault, increased sag, Pole tilt these are the faults which are reduced.

Key Words: Transmission line failue, over voltage, pole tilt.

1. INTRODUCTION

An electric power supply system comprises the generating station, transmission lines and the distribution system. In generating station, power is generated by three phase alternators operating in parallel. To transmit the electricity from the point of generation to the end user, an interconnected network of electric grid is used. The network of electric grid consists of countable number of generating stations, high-voltage transmission lines and distribution lines. We know that when a low voltage power is transmitted over long distance, the power loss we acquire will be more.

Though regular maintenance is carried out periodically, some unexpected issues arises due to

trees, wind, construction, and corrosion caused by the wind coming through the sea water in the overhead transmission lines near the sea shore. Though, manpower is allocated for maintaining the transmission lines, it is difficult and a time consuming process. Mostly for tracking the point of failure, one has to climb multiple posts (towers) across the transmission line which is cumbersome activity.

2. PROPOSED SYSTEM

Different approaches could be adopted for dealing with the transmission line failure. A few of them are described in detail in this section.

2.1. INTERNET OF THINGS (IOT)

The internet of things or IOT, is a system which is connected between the devices, analog, mechanical and digital machines, objects, animals or people that are provided with unique identifiers (UIDs) and the ability to sending data over a network without requiring human-to-human or human-to-computer interaction. The Internet Of Things is simply defines "A network of Internet connected object able to collect and transfer data". IoT is the concept of connecting any device with an ON and OFF switch to the internet and

Tilt sensors are devices that produce an electrical signal that varies with an angular movement. These sensors are used to measure slope and tilt within a limited range of motion. Sometimes, the tilt sensors are referred to as inclinometers because the sensors just generate a signal but inclinometers generate both readout and a signal.

2.2. HARDWARE COMPONENTS

Arduino Mega: It is a developer board based on ATmega2560 microcontroller. It has memory for code storage and the coding can be done using Arduino software IDE.

Wi-Fi module: The module used in this project is ESP8266. It has an integrated TCP/IP protocol stack that gives the Arduino mega 2560 microcontroller access to the wi-fi network. It also has storage capability.

Relay: It is basically a digital switch that is used for switching voltages and currents. The relay performs switching actions based on the input provided by the user.

LCD: It is a colorful LCD display which uses I2C protocol to communicate with the microcontroller.

RS232: It was used as a standard port for communication between different devices like printers, mouse, modems and all other type of computer peripherals and the computer.

Potential transformers: They are basically step down transformers with extremely accurate turns ratio. Potential transformers step down the voltage of high magnitude to a lower voltage which can be measured with standard measuring instrument.

3. Hardware Setup

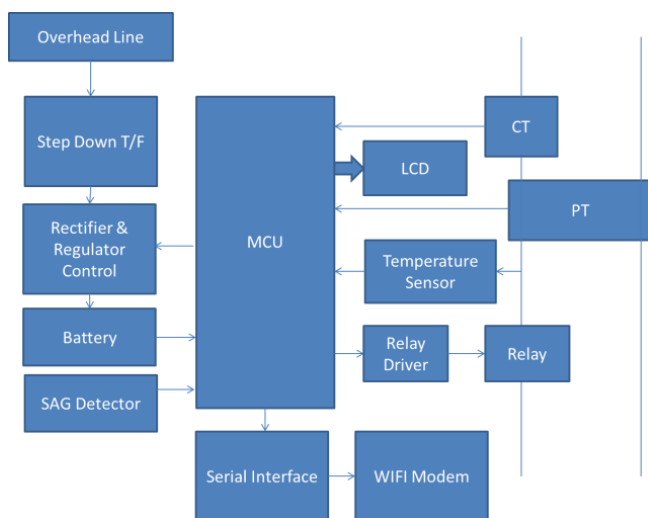

Fig. 1. Block Diagram

Current transformer: It is a type of instrument transformer designed to provide a current in its secondary winding proportional to the alternating current flowing in its primary.

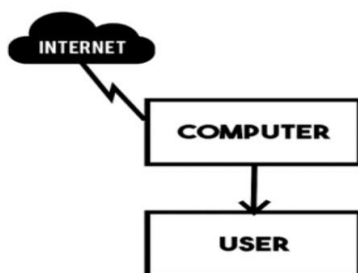
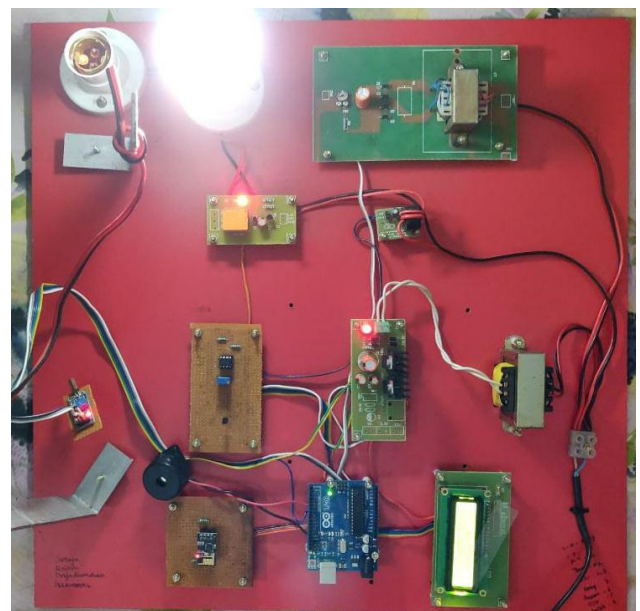
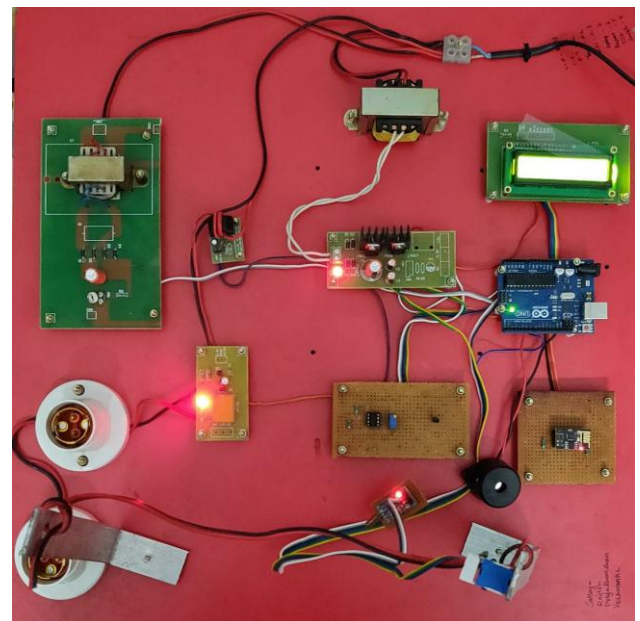

Fig. 2. Internet of Things



3.1. IMPLEMENTATION

When AC is applied to the primary winding of the power transformer it can either be stepped down or up depending on the value of DC needed. In our circuit the

transformer of 230v/15v is used to perform the step down operation where a 230V AC appears as 15V AC across the secondary winding. In the power supply unit, rectification is normally achieved using a solid-state diode. Diode has the property that will let the electron flow easily in one direction at proper biasing condition. As AC is applied to the diode, electrons only flow when the anode and cathode is negative. Reversing the polarity of voltage will not permit electron flow. A commonly used circuit for supplying large amounts of DC power is the bridge rectifier. A bridge rectifier of four diodes (4*IN4007) is used to achieve full wave rectification will aid the rectifier and filter circuit in providing a constant DC voltage to the device. Power supplies without regulators have an inherent problem of changing DC voltage.

The Arduino Uno is a microcontroller board based on the ATmega328. It has 14 digital input/output pins (of which 6 can be used as PWM outputs), 6 analog inputs, a 16 MHz crystal oscillator, a USB connection, a power jack, an ICSP header, and a reset button.

The LCD we have used in this project is HD1234. This is an alphanumeric type of LCD with 16 pins. Of which Pins 7 to 14 are used as data pins, 11 to 14 pins are connected to port D of microcontroller. There are 3 control pins RS (Pin-4), RW (Pin-5) and EN (Pin-6).

ESP8266 Wi-Fi module is a self-contained system on chip (SoC) with an integrated TCP/IP protocol stack that can give any MCU access to your Wi-Fi network. ESP8266 is capable of either hosting an application or off-loading all Wi-Fi networking functions from another application processor.

3.2. FUTURE SCOPE

- Underground Line fault Detection
- Data Logging

3.3. ADVANTAGES

- Work in real time response inter.
- Coverage area in large compared to existing system.
- Cost efficient.
- Devices enable by wireless communication.
- Number of components are used
- Economically reliable and low cost.

4. CONCLUSION

The model design in such a way to solve the problems faced by consumer. By using such method, we can easily detect the fault and resolve it. It is highly reliable and locate the fault in three phase transmission line and also supposed to data storage. It works on real time so we maintain all data sheet and avoid the future problem in transmission line.

4.1. REFERENCES

- [1] Ms.Devjani Banerjee, Prof Dr.Mrs.N.R.Kulkarni , "Three Phase Parameter Data Logging and Fault Detection Using GSM Technology", International Journal of Scientific and Research Publications, Volume 3, Issue 2, February 2013 1 ISSN 2250-3153
- [2] P.A. Gulbhile, J.R. Rana, B.T. Deshmukh, " Review for overhead line fault detection using GSM technology", International Journal of Advanced Research in Electrical, Electronics and Instrumentation Engineering, Volume 5, Issue 12, December 2016 ISSN 2278-8875
- [3] K. Saravanababu, P. Balakrishnan and K. Sathiyasekar, "Transmission line faults detection, classification, and location using Discrete Wavelet Transform," 2013 International Conference on Power, Energy and Control (ICPEC), Sri RangalatchumDindigul, 2013, pp. 233-238.
- [4] M. Singh, B. K. Panigrahi and R. P. Maheshwari, "Transmission line fault detection and classification," 2011 International Conference on Emerging Trends in Electrical and Computer Technology, Tamil Nadu, 2011, pp. 15-22.
- [5] Neeta S. Sonwane¹, Dr. S. D. Pable², "Fault detection and autoline distribution system with Gsm module", International Research Journal of Engineering and Technology (IRJET) e-ISSN: 2395 -0056 Volume: 03 Issue: 05
- [6] M. F. Othman and H. A. Amari, "Online fault detection for power system using wavelet and PNN," 2008 IEEE 2nd International Power and Energy Conference, Johor Bahru, 2008, pp. 1644-1648.
- [7] A. Cozza and L. Pichon, "Echo Response of Faults in Transmission Lines: Models and Limitations to Fault Detection," in IEEE Transactions on Microwave Theory and Techniques, vol. 64, no. 12, pp. 4155-4164, Dec. 2016.
- [8] C. Zhang and L. Zhou, "220kv Transmission Line Fault Diagnosis and Analysis," 2012 Second International Conference on Intelligent System Design and Engineering Application, Sanya, Hainan, 2012, pp. 1343- 1345.