

Development of Microcontroller Based Bluetooth Controlled System for High Power Electric Appliances

G. B. Bhagat¹, A. R. Patil¹, P. V. Mane-Deshmukh², S. K. Tilekar³ and S. A. Pawar⁴

¹Department of Electronics, KBP Mahavidyalaya, Pandharpur, MS, India

²Head, Department of Electronics, Jayawantrao Sawant College of Commerce and Science, Pune, MS, India

³ Head, PG Department of Electronics, S. M. Mahavidyalaya, Akluj, MS, India

⁴Department of Electronics, ShriShivajiMahavidyalaya, Barshi, MS, India

Abstract - Indeed, state of the art technology is playing significant role in the development of wireless controlled high power electric appliances for diversified application. On survey, it reveals that investigators utilized different wireless controlled technologies in hazardous and containment zones. Keeping eye on hours need, inexpensive and robust embedded system is designed deploying MCS-51 series device and Bluetooth technology to precisely control the power of electric appliances. Hence, AT89S52 microcontroller is deployed for the present prototype embedded system. This AT89S52 has low-power, high-performance CMOS 8-bit, In-System Programmable (ISP) Flash memory, etc. as promising features. The HC-06 Bluetooth sensor module is interfaced to the AT89S52. Holistically, Bluetooth technology has good performance features than IR technology, low power consumption, immune to interference, good range, easily upgradable, etc. The TRIAC driven optocoupler, MOC3021 is wired around AT89S52 to control the high power electric appliances using TRIAC BT136. The firmware is developed in embedded C, using Kiel μ Vision3, as an IDE. In this work, developed embedded system is tested through Mobile Bluetooth App and depicted in this paper.

Key Words: Bluetooth, AT89S52 microcontroller, embedded system, Optocoupler, etc.

1. INTRODUCTION

Upon industrial survey, it is observed that many high power appliances or devices are used. The people has to operate these devices manually, sometimes it becomes risky for them. Therefore safety of peoples plays very important role in various industrial sectors. If such types of high power devices are operated remotely, it becomes very safe for the operators. Therefore most of the researchers are showing more interest in designing of various embedded systems for controlling of high power devices in industrial sectors. It makes tremendous revolutionary changes in the design and development of industrial electronics embedded devices. Microcontroller based embedded systems are also widely used in the field of domestic, telecommunication, process control, industries and R&D as well [1, 2, 3]. The development of mobile operated embedded system using Bluetooth Technology becomes suitable for remote controlling of high power devices. An embedded system is one that has computer-hardware with software embedded in it as one of its most important component [4].

Using Android application user can send the commands to the Bluetooth module to control the electrical loads. The Bluetooth module receives the commands from the Android Application installed in the Mobile Phone, using wireless communication technology (Bluetooth). The software loaded in Microcontroller communicates with Bluetooth module serially to receive the commands. Microcontroller switches the electrical loads automatically based on the commands received from the Bluetooth module. Therefore, it is proposed to design and develop an embedded system for precise control of high power devices by using android mobile phone. For various dedicated applications, the high performance microcontroller based embedded systems are found most reliable. Most of the designers are designing the systems based on 8031 and 8051 microcontrollers having sufficient on chip resources. However, to develop small embedded systems, the microcontrollers from 8051 families are more suitable. The microcontrollers are becoming an integral part of engineering design known as embedded system [5]. Hence, an embedded system for controlling the high power devices is designed by using AT89S52 microcontroller and Bluetooth module HC-06 and is presented in this paper.

2. DESIGNING OF THE SYSTEM

Based on AT89S52 microcontroller, the Bluetooth Controlled System is designed for controlling of High Power Electric Appliances by using the hardware such as Android mobile phone, Bluetooth sensors HC-06, LCD display module, control unit, power supply circuit etc. and implemented successfully. The block diagram of the designed system is presented in Figure 1 and schematic of the circuit designed for embedded system is depicted in Figure 2.

For working with high power electric appliances in hazardous zones, safety of the people along with sharp controlling of appliances is very important. Therefore, a Bluetooth module, HC-06 is deployed in the present system to connect the microcontroller based system with android phone. The module HC-06 is designed for transparent wireless serial connection with serial port setup. It is low power, PIO control with integrated antenna, edge connector, due to which it becomes very smart and is easy to use with Bluetooth SPP (serial port protocol). It is excited with +5 V power supply and having low power consumption. The operating temperature range of this module is -25°C - 75°C [6].

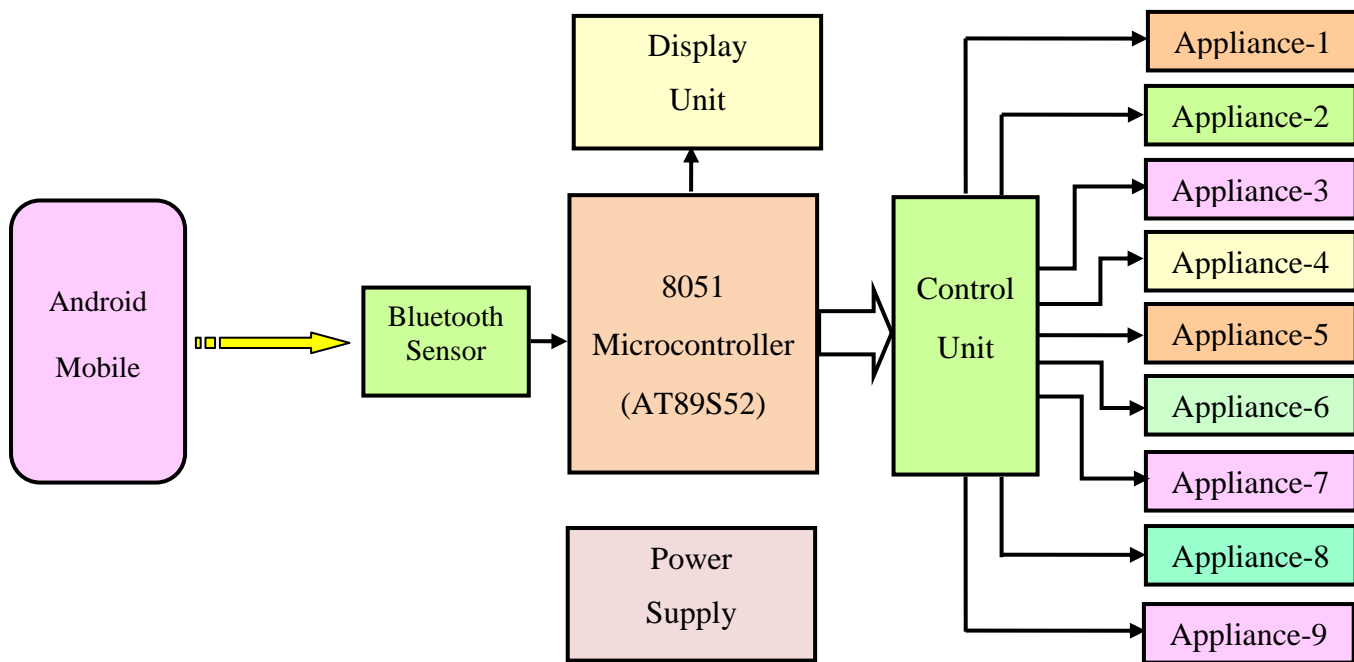

Figure 1: Block diagram of the System under investigation

The status of each appliance is displayed on the LCD module, which is interfaced to the microcontroller using Port P2 (data lines) and Port P3 (control lines) as depicted in figure 2. The Zero-Crossing TRIAC driven optocoupler MOC3021 is used to isolate the high power devices from microcontroller. The TRIAC - BT 136 is used to control the switching action of all the high power devices connected to the system at Port P1.

To connect the system with Android mobile phone, Bluetooth app 'Arduin Remote' is installed by downloading from Google play store as depicted in figure 3. The device gets turned ON and OFF by touching the respective button in the Bluetooth mobile app.

There are 9 buttons in the app which are assigned for each device. When user will press any button in Bluetooth controller app then Android phone sends a code to Bluetooth module. After receiving this code, Bluetooth module sends the received code to the microcontroller. Then microcontroller reads it and compares with predefined codes in the program. If any match is occurred then microcontroller performs the relative task. i. e. turns ON the corresponding device and displays its status on LCD display. Same operation will be performed each time when button is pressed.

For example when user touches Device-1 'On' button in Bluetooth app, then microcontroller receives 'A' via Bluetooth module and controller Switches ON the Device-1. Similarly when user touches Device-1 'Off' button in Bluetooth app, then microcontroller receives 'a' via Bluetooth module and controller Switches OFF the Device-1. Likewise B, b, C, c characters are sent by Android Phone to microcontroller through Bluetooth sensor, when Device-2 'On', Device-2 'Off', Device-3 'On', Device-3 'Off' button has been touched respectively. The following table 1 shows different codes for various buttons in the mobile app.

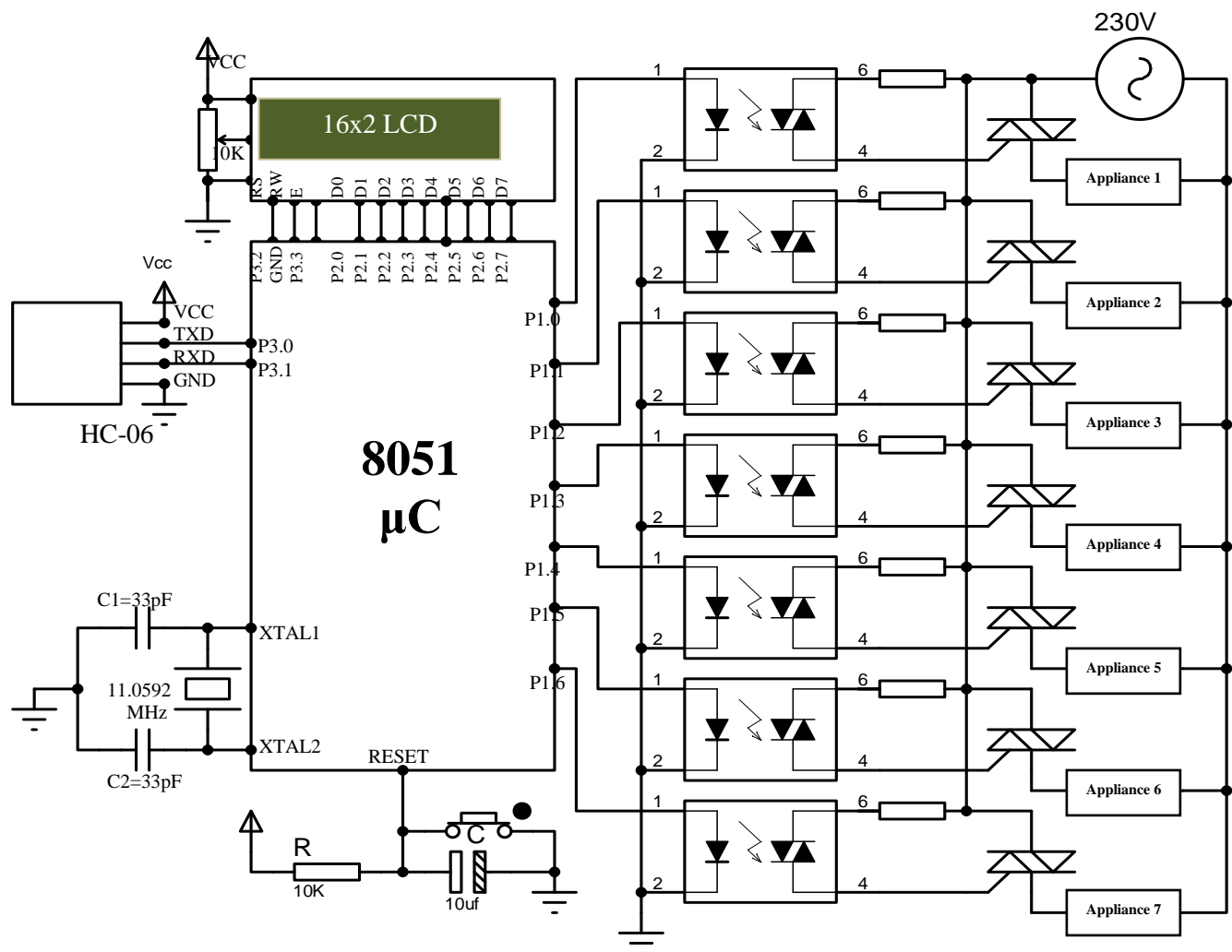

Figure 2: Schematic of the System under investigation

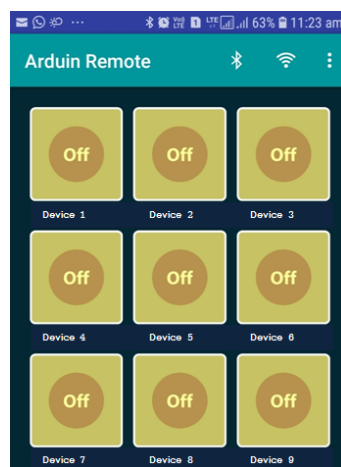

Figure 3: User interface of 'Arduin Remote'

Table 1: Codes for various buttons in the mobile app

Sr. No.	Button	Code for 'ON' Condition	Code for 'OFF' Condition
1	Device-1	A	a
2	Device-2	B	b
3	Device-3	C	c
4	Device-4	D	d
5	Device-5	E	e
6	Device-6	F	f
7	Device-7	G	g
8	Device-8	H	h
9	Device-9	I	i

In order to run the embedded system properly as per design considerations, the hardware and software are two inherent things. In previous paragraph necessary hardware part of the system is illustrated. However, by using Keil μ Vision3 Integrated Development Environment (IDE), the firmware is consequently designed in embedded C. The software developed to embed into the target device is also referred as firmware [7]. The flow chart of developed firmware is depicted in Figure 4. The hex file of program is generated after successful building of the project and burned into the target device AT89S52 microcontroller which ensures the synthesized embedded system for controlling the ON/OFF action of high power electric devices.

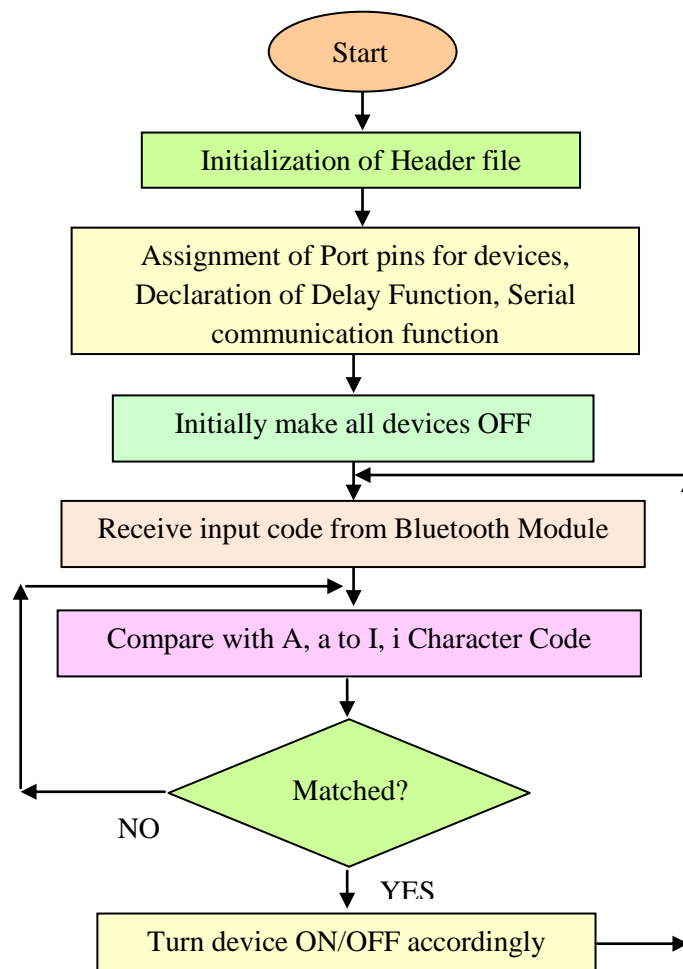

Figure 4: flow chart of developed firmware

3. DEPLOYMENT OF SYSTEM

In present work, state of each appliance is controlled and displayed on LCD display by developing an embedded system. As depicted in Figure 5, an embedded system is developed in the laboratory and used for controlling of ON/OFF action of high power appliances and results are discussed. As the Bluetooth app 'Arduin Remote' has nine switches, the system can be used to control nine appliances. There are different types of Bluetooth apps available on play store which can be used for same application. After installation of app in mobile, each switch is labeled with proper name through settings. Upon powering the system, it should be paired with android mobile phone using Bluetooth. For testing of the designed system, nine lamps are used as high power appliances. Initially all the switches are in OFF state and as per the need if user hit any switch then the corresponding appliance gets turned ON and also message of the same gets displayed on LCD. Similarly, upon hitting same switch once again, the corresponding appliance becomes OFF. Thus, AT89S52 microcontroller based embedded system is developed and tested successfully for precise controlling of high power electrical appliances.

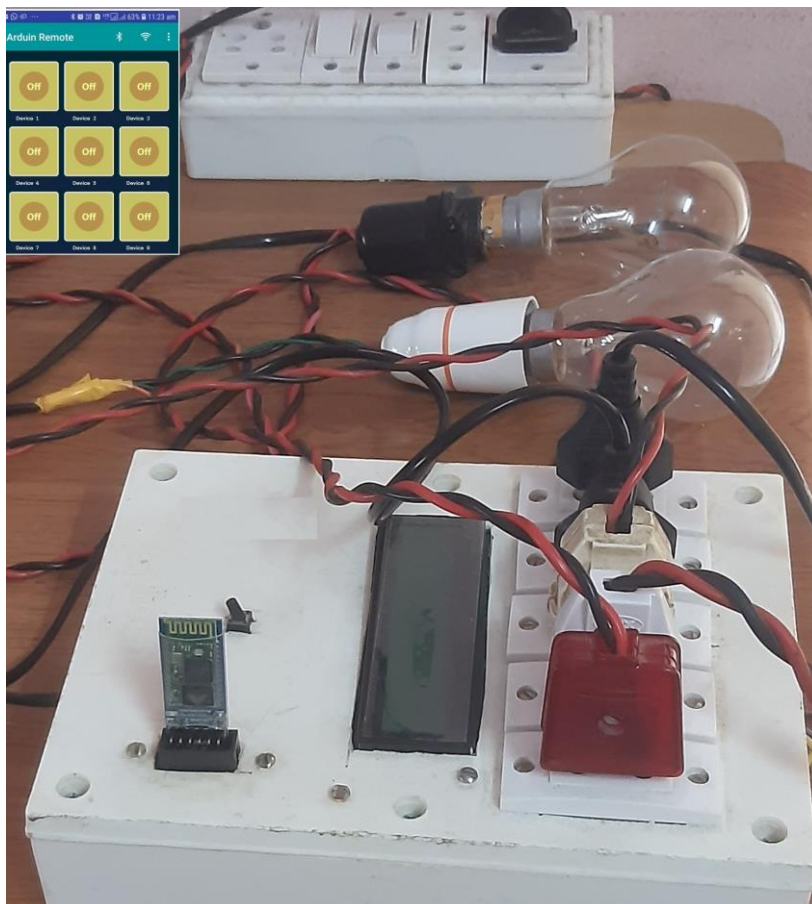

Figure 5: Prototype of developed system

3. CONCLUSIONS

By emphasizing embedded technology, a smart Bluetooth controlled electronic system is designed about AT89S52 microcontroller to monitor and control the status of high power electric appliances. The system is tested successfully to turn ON and OFF electric appliances using android mobile phone. Experimental results shown by the present system to control the ON/OFF action of electric device are more precise which reveal the preciseness in the development of the system.

REFERENCES

- [1] P. V. Mane-Deshmukh, B. P. Ladgaonkar, S. C. Pathan, S. S. Shaikh, "Microcontroller PIC 18f4550 Based Wireless Sensor Node to Monitor Industrial Environmental Parameters", International Journal of Advanced Research in Computer Science and Software Engineering, 3 10 (2013) 943-950.
- [2] P. Sushmita and G. Sowmyabala, "design and Implementation of Whether Monitoring and Controlling System", Int. J. of Comp. Application, (2014), 97(3), 19-22.
- [3] P. V., Mane Deshmukh (2019). Designing of the Smart Patient Transportation System. i-manager's Journal on Embedded Systems, 8(1), 24-30..
- [4] R. Kamal, "Embedded system Architecture Programming and Designing", TMH, New Delhi (2003).
- [5] T. D. Morton, "Embedded microcontrollers", Pearson education, New Delhi (2005).
- [6] Datasheet of Bluetooth Module HC-06
- [7] M.J.Pont,"Embedded C", Addison-Wesaly, London(2005)