

Methods to Prevent Fuel Leakage in Dispenser Units

Sheshadri R¹, Nikhilesh S², Haritha D³

¹Student, Dept. of Mechanical Engineering, PSG College of Technology

²Student, Dept. of Mechanical Engineering, PSG College of Technology

³Student, Dept. of Electrical and Electronics Engineering, PSG College of Technology

Abstract – In a competitive business environment, competitors who follow “Value for money” have a high probability of attracting customers. In the same notion, the customers also expect the business units to provide service (commodities) for the money they pay. Narrowing down the area of concern to fuel-filling bunks, a large amount of fuel is getting wasted as fuel leakage prevails in most of the existing fuel nozzles. The wasted fuel is neither beneficial to the organization nor the customer. This paper will discuss various techniques that can be employed to prevent fuel leakage from the nozzles.

Key Words: Fuel dispenser units, leakage prevention, anti-drain valve,

1. INTRODUCTION

Petrol is a fossil fuel that takes millions of years to form and the extraction process is also difficult and involves a lot of effort. Thus, we must use the fuel without any wastage. The nozzles in the existing fuel dispensers involve fuel leakage at the end of the fuelling process, it neither enters the fuel tank nor returns to the fuel storage tank (placed underground in the fuel station). This problem can be avoided by the use of an anti-drain valve that will be mounted to the existing fuel nozzle to avoid any possible fuel leakage. The design of the anti-drain valve will be discussed in detail in this paper.

2. FUEL DISPENSER - REVIEW

Fuel dispenser unit is a device that dispenses (transports) the required amount of fuel from the fuel storage tank to the fuel tank in the vehicle. The current design of the fuel dispensing nozzle is as shown in fig 1.

The existing nozzle consists of an in-built anti-drain valve (part no. 7 in fig 1.). This anti-drain valve depends on the movement of the level which is used to turn ON and OFF the fuel flow. When the lever is opened the anti-drain valve, which is governed by a spring, also opens creating a way for the fuel to enter into the fuel tank, vice versa when the lever is closed the anti-drain valve also closes thereby preventing any further fuel flow into the fuel tank. The main disadvantage of this system is that at the end of the fuelling process the fuel that has crossed the anti-drain valve and hasn't reached the fuel tank will remain in the nozzle. This fuel will drip out from the nozzle which is a wastage. To avoid this issue the person who is re-fueling will shake the nozzle

so that any fuel present will reach the tank. This cannot be used as it is ineffective and it does not guarantee that all the fuel droplets will reach the tank. To avoid this problem the solution proposed is to cascade an anti-drain valve at the exit of the nozzle to prevent any fuel leakage.

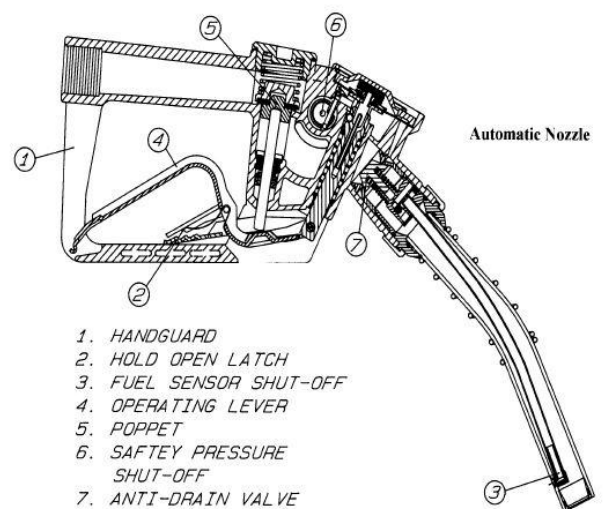

Fig -1: Cross-section of the existing fuel nozzle [1].

3. ANTI - DRAIN VALVE - DESIGN

The design of an anti-drain valve is as shown in fig 2.

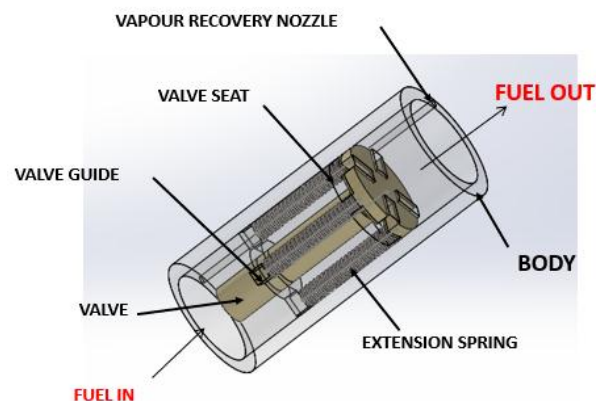

Fig -2: Anti - drain valve - closed position.

The anti-drain valve consists of a valve which is guided by a spring. The working of the anti-drain valve is very simple, the fuel which is pumped from the fuel storage tank comes at

a pressure of 3 bar. When the anti-drain valve is placed at the end of the nozzle the fuel will exert a pressure on the valve thereby making the valve move up. This movement of the valve will create room for the fuel to enter the fuel tank. At the end of the fueling process the pressure of the fuel drops and the valve slowly closes, at an instant of time when the lever has closed the pressure of the fuel would not be enough to open the valve thus preventing any fuel leakage. The valve in the open position is shown in fig 3.

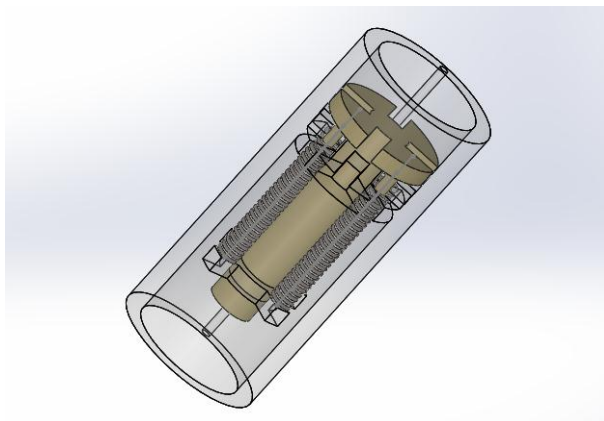

Fig -3 Anti - drain valve - open position.

The springs incorporated in the design are extension springs designed based on the pressure of the fuel. The calculation of the spring stiffness is as shown below:

Table - 1: Parameters

Label	Value
Modulus of rigidity (G)	79.3 GPa
Number of turns (N)	6
Coil diameter (d)	2 mm
Spring diameter (D)	2 mm
Spring index (C)	1

$$\text{Pressure} = 3 \text{ bar} \mid \text{Area} = 25 \times 4 = 100 \text{ mm}^2$$

$$\text{Pressure} = \text{Force}/\text{area}$$

$$\text{Force} = \text{Pressure} \times \text{Area}$$

$$\text{Force} = 35 \text{ N}$$

$$\begin{aligned} \text{Spring stiffness, } k &= G \times d / (8C^3N) \\ &= 79.3 \times 10^9 \times 2 \times 10^{-3} / 8 \times 1^3 \times 6 \\ &= 3.3 \text{ N/mm} \end{aligned}$$

4 springs are connected parallel

$$\begin{aligned} \text{Total stiffness} &= 4 \times 3.3 \\ &= 13.2 \text{ N/mm} \end{aligned}$$

4. FLOW SIMULATION

Flow simulation was performed on the above-mentioned design to predict any possibility of vortex formation in the system as it will lead to a pressure drop in the system, making the system inefficient. The analysis was performed using Ansys FLUENT v18.1 and the results obtained are

shown in fig 4. The fig shows the streamlines of the fluid in the system. The results reveal that there is no vortex formation in the system and the pressure in the system is also unaltered [2]. Due to the decrease in the area of fuel flow at the end there is a small rise in the velocity of the fuel which also reduces the fueling time.

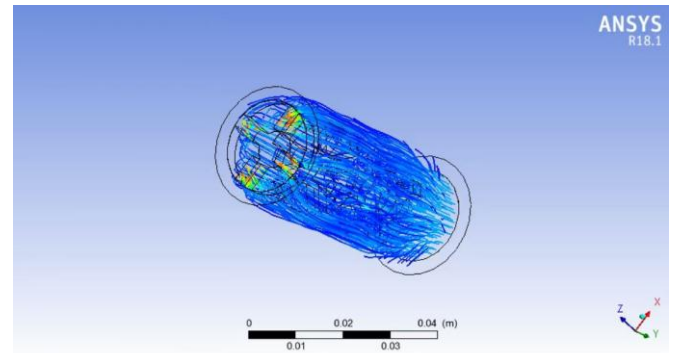

Fig -4 Streamlines.

5. BOOTHROYD APPROACH - ASSEMBLY TIME.

Various considerations have to be made when the anti-drain valve is manufactured on a large scale. One important consideration is how the individual components are assembled and the corresponding time involved in the same. Based on this, the assembly efficiency can be calculated with the help of Boothroyd charts. The time taken for individual components is as shown in fig 5.

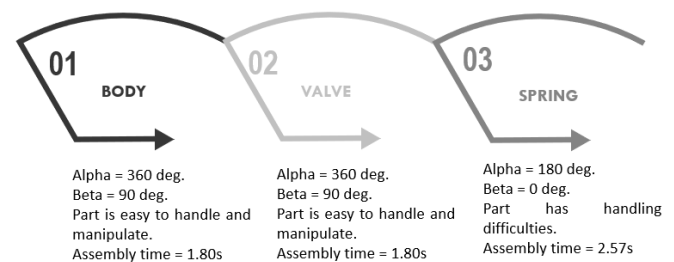

Fig -5: Assembly time [3].

From the above analysis, using the Boothroyd chart the total time taken for assembly is 10.67 s. This will increase the number of parts that can be made and has a positive impact on the per piece cost.

Theoretical minimum number of parts, $N_{min} = 3$

Time taken for assembly, $T_{ma} = 10.67 \text{ s}$

Average time taken without any handling, $T_a = 8 \text{ s}$

$$\begin{aligned} \text{Assembly efficiency} &= N_{min} \times T_a / T_{ma} \\ &= 3 \times 8 / 10.67 \\ &= 22.47 \% \end{aligned}$$

6. SHUTTER VALVE

Another effective and simpler way of avoiding fuel leakage from the nozzles is with the use of a shutter valve. The design of the shutter valve is as shown in fig 6. Shutter valve is an external attachment to the nozzle outlet, which is equipped with shutters mounted on a torsion spring which pivots about a rigid rod passing through the valve in transverse direction. The outer lining where the shutters seat is provided with a magnetic strip lining, which keeps the shutter in place.

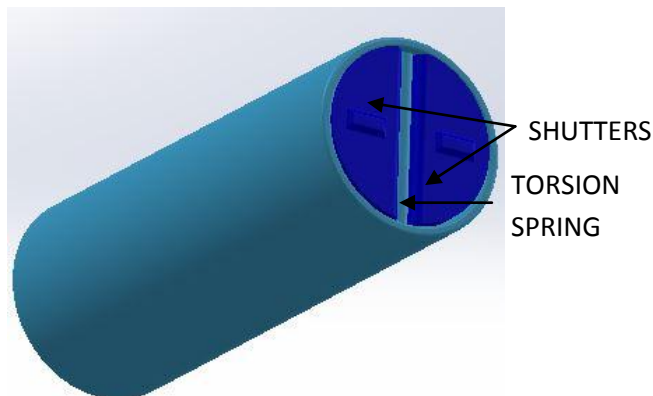

Fig -6: Shutter type valve – Closed Position

When the fuel at high pressure hits the shutters, the shutters tends to open and to keep them vertical enough stoppers are placed at the top. The shutters are also fixed with a torsion spring at the center which twists and stores energy. When the pressure of the fuel drops the energy stored in the torsional spring gets released and the shutter comes back to its initial position and attaches itself to the magnetic strip.

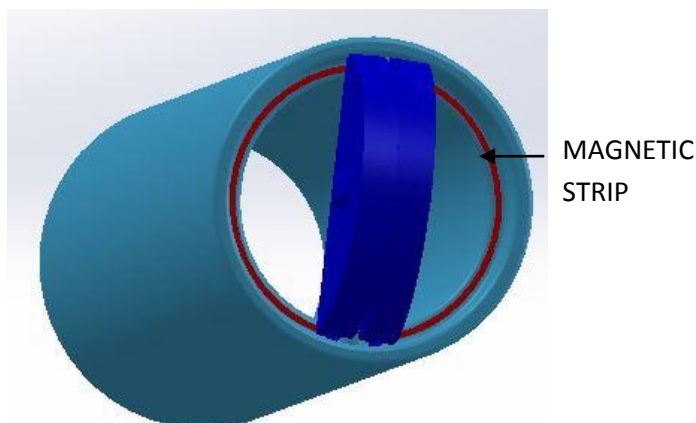

Fig -7: Shutter type valve – Open Position

7. FABRICATION

The process of building a 3D object from a CAD model, usually by successively adding material layer by layer. 3D printing is an additive manufacturing (AM) technique. We have employed 3D printing – Fused Deposition Modelling for

prototyping the model. This inexpensive, easy-to-use process can be found in most non-industrial desktop 3D printers.

It uses a spool of thermoplastic filament which is melted inside a printing nozzle barrel before the resulting liquid plastic is laid down layer-by-layer according to a computer deposition program as shown in fig 8.

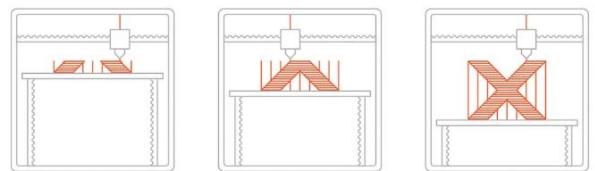

Fig -8: Fused Deposition modelling.

Material used: PLA (Poly Lactic Acid).

There are various advantages involved in using PLA for 3D printing such as greater water dissolvable support material, no special solvents required and it does not involve any special hardware. The steps involved in 3D printing is as shown in fig 9.

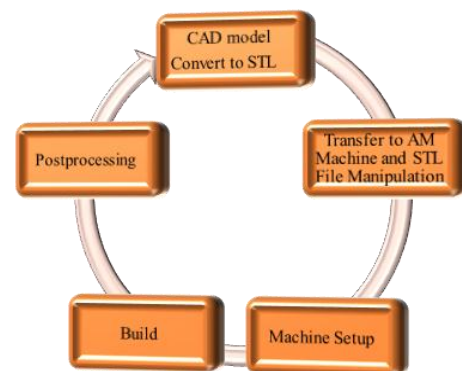

Fig -9: 3D printing process cycle.

Based on the above process, the CAD file was converted to STL file and fed into a slicer software which divides the model into number of layers. This sliced model is fed into the 3D printer and the design was fabricated as shown in fig 10.



Fig -10: Desktop 3D printer.

8. CONCLUSION

The paper discusses about various techniques that can be employed to reduce the fuel leakage in the fuel nozzle. Two potential techniques have been discussed. The first anti-drain valve employs a large number of components. The efficiency of the system drops as the number of components increases. Owing to the simplicity and effective operation, the shutter type valve outruns the anti-drain valve.

REFERENCES

- [1] Mitchell, Thomas O, Fink, Arthur C., Jr. Lonedell, Vapor control valve for a vapor recovery fuel dispensing nozzle, 1995.
- [2] N. Sinha, R. Thompson and M. Harrigan, Computational simulation of fuel shut-off during refueling, SAE Technical Paper Series, Paper 981377, Society of Automotive Engineers, (1998).
- [3] Geoffrey Boothroyd, Peter Dewhurst, "Product Design for Manufacturing and Assembly", Winston Knight, Merce Dekker, 2001