

# Design of Resistor-Capacitor Timer Switch for Home Application

Anuj Goyal<sup>1</sup>, Aanjan Patodia<sup>2</sup>, Pranav Nelge<sup>3</sup>

Department of Mechanical Engineering, Vishwakarma Institute of Technology, Maharashtra, India

\*\*\*

**Abstract** - Timer switches are promising to dramatically reduce the power consumption and thereby saving time and energy. Also, due to them, automation has become very easy. One major technical challenge addressed in our project is to select the appropriate values of the capacitor and resistor so that the timer switch will give the desired results. Based on careful analysis of application requirements, we can make the timer switch of required voltage, current, power, and time for which the device will work. The potentiometer helps to control the resistance, which indeed decides the time since the capacitor is kept of constant value. Further, changing the values of capacitor and resistances, the time for which the switch will work changes. A relay is used for changeover and a power supply to convert the 230V AC voltage to 12V. To help our study we also took the help of industrial timers to study their variation and understanding of how a timer works.

**Key Words:** timer, analog, digital, PLC, preset, on-delay

## 1. INTRODUCTION

A timer switch may be a sort of timer that operates an electrical switch controlled by the timing mechanism. The switch could also be connected to an electrical circuit operating from mains power, including via a relay or contactor; or low voltage, including battery-operated equipment in vehicles. It may be built into the power circuits (as with a heating system or hot-water heater timer), plugged into a wall outlet with equipment plugged into the timer rather than directly into the facility point; or built into equipment as, for instance, a sleep timer that turns off television after a group period. The mechanism may be mechanical (e.g. clockwork; rarely used nowadays), electrochemical (e.g. a slowly rotating a geared motor that mechanically operates switches) or electronic, with semiconductor timing circuitry and switching devices and no moving parts. A timer may switch equipment on, off, or both, at a preset time or times, after a preset interval, or cyclically. Time switches can be used for many purposes, including switching equipment on, off, or both at times required by some process, and home security (for example switching lights in a pattern that gives the impression that premises are attended) to reduce the likelihood of burglary or prowling.

## 2. OBJECTIVES

### 2.1 Convenience

One of the explanations why homeowners should consider installing time switches reception is that the convenience of controlling certain electronic appliances automatically. You

can continue with whatever you're doing and not bother with certain chores. If you're forgetful, you'll also enjoy installing a timer switch. Also, if you say you want to sleep early but you have to keep the lights ON until 3 in the morning, you can leave the time switch to control the lights while you are asleep.

### 2.2 Safety

Survey shows that most intruders target empty homes. If you say, you'll go on a vacation but you're worried about safety, a time switch can help ward off suspicious characters from the premises. A timer switch allows you to preset the days when the lights turn on and off. When the lights turn on and off at certain hours, the world is far safer. It will deter burglars or intruders from breaking into your home.

### 2.3 Save More Money

There's absolutely no need to keep your lights on the whole day and night, especially when you're away from home. Using a time switch will prevent money on utility bills because the device controls when to modify on or off the lights. "Timer Switches" are often specifically helpful for residential societies or big setups/offices where people tend to go away lights switched on even once they aren't required.

### 2.4 Benefits with all other appliances

We mentioned that several appliances consume electricity if they're not transitioned from the mains (switched off only from remote). This results in a lot of electricity wastage. A "Timer Switch" can confirm that the appliances are transitioned during that point of the day when those appliances are surely not required. This can result in significant electricity savings.

### 2.5 Environment benefits

Saving our environment is a priority for most organizations now as they can see the weather change and global warming. The RC timer reduces the amount of electricity used as it automatically switches off the given appliance as many people forget to or don't do it. Saving electricity means saving costs and also reducing the loads on the devices and resources generating the electricity.

## 3. METHODOLOGY

### 3.1 IC-555 Timer

This kind of timer is similar to R-C timer but this made using a 555 IC [1]. These are some of the most common timers used in domestic use. You can also change the function of these by modifying the circuit. For example, instead of using it as a

timer we can modify the circuit and use it as a counter. The IC is used in the monostable state for this circuit.

### 3.1.1 Components

1. 555 timer
2. Electrolytic capacitor – 470 μF
3. Ceramic capacitor – 0.1nF
4. Resistors
5. Relay -12v
6. Push button
7. Breadboard

### 3.1.2 Circuit Diagram

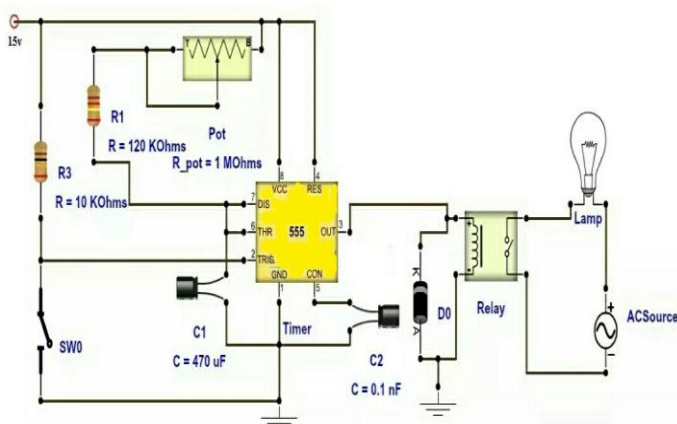

Fig 1: Circuit Diagram for IC-555 Timer

### 3.1.3 Working

1. A push-button is used to initiate the circuit.
2. The trigger input is applied; 555 timer produces a pulse. This pulse width depends on R and C values.
3. The above-proposed circuit is a 1-10-minute timer. When Potentiometer (pot) is minimum it gives a 1-minute delay, where a maximum value of pot can produce 10 minutes.
4. A 12v relay is used to drive the ac load connected at the output.
5. Thus relay will be on for a required amount of time set by the user using pot and then it is switched off automatically.
6. Time period can be calculated using the formula:  
 $T = (R1 + R2) * C1$ . seconds
7. When the Potentiometer is maximum, R is  $120K + 1.1M \approx 1.2M$  (approximately) and  $C1 = 470\mu F$ ,  
 $T = 1.2M * 470\mu F = 620 \text{ sec} \approx 10 \text{ min}$ .
8. For minimum time place the pot in the least position. Then  $R = 120k$ ,  $T = 120k * 47000\mu F = 62 \text{ sec} \approx 1 \text{ min}$

### 3.2 PLC Timer

The programmable logic controller is an industrial control computer there are a lot of tasks made easier with the help

of PLC. PLC has also made hard wiring less and control of applications easier. With the help of PLC, we can add a number of timers in a single circuit without the cost of an actual one. Timers in PLC are of three types: ON-DELAY, OFF-DELAY, and INTERVAL. Timers are added in the rungs in the circuit on the PLC program. These are industrial timers.

- ON Delay – When the timer coil is energized there is a delay before the contacts change position. The contacts remain in the changed position until the timer coil is de-energized at which time the contacts return to the normal position immediately.
- OFF Delay – When the timer coil is energized the contacts change position immediately and remain in the changed position. When the timer coil is de-energized there is a delay before the contacts return to the normal position.
- Interval (One-shot) – When the timer coil is energized the contacts change immediately and remain in the activated position for the duration of the preset time period after which they return to their normal position.

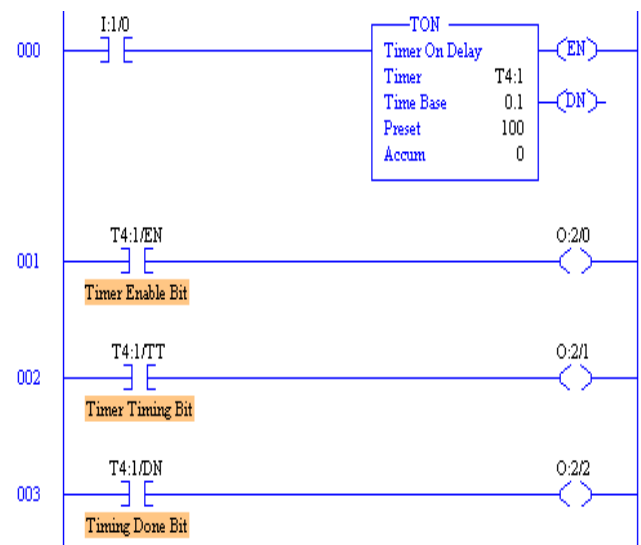

Fig 2: PLC Timer Circuit

### 3.3 Industrial Timer

These are timers are used in industries. They are larger in size to carry higher voltages and current values as industries require higher current and voltage values. These timers are expensive. In industries, a number of such timers are used in combinations to operate machines, robots, etc. The use of physical industrial timers is becoming lesser as companies are moving on to PLCs.

Industrial timers can work as an interval or on-delay timers. It has 2 terminals for normally open contact and 2 terminals

for normally closed contacts and the other 2 terminals are power source [7-8].

**• Setup**

1. First, connect the wires in Normally Open
2. Normally Closed contacts depending on our requirements.
3. Give supply to terminals A1, A2.
4. Select the mode with 4 the switch on the side of the timer.
5. Then use the third switch to select a time in minutes or seconds.
6. Scale can be decided by using the first 2 switches. The scale has 4 values 3,10,30,60, which gets multiplied to the time you select.
7. With the help of the round dial, you can set the value from 0 to 10 which gets multiplied by the scale [8].

**3.4 Resistor-Capacitor (RC) Timer**

These are timers are used in industries. They are larger in size to carry higher voltages and current values as industries require higher current and voltage values. These timers are expensive. In industries, a number of such timers are used in combinations to operate machines, robots, etc. The use of physical industrial timers is becoming lesser as companies are moving on to PLCs.

Industrial timers can work as an interval or on-delay timers. It has 2 terminals for normally open contact and 2 terminals for normally closed contacts and the other 2 terminals are power source [7-8].

**3.4.1 Components**

1. BC547 Transistor
2. 1000  $\mu$ F Capacitor
3. 100K Potentiometer
4. 12V Power Supply
5. Push Button
6. 12V SPDT Relay
7. 1N4007 Diode
8. Electrical Wires

**3.4.2 Circuit Diagram**

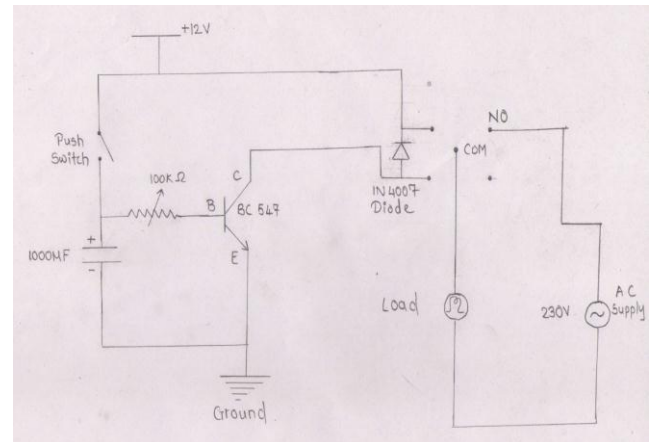

**Fig 3:** Circuit Diagram for RC-Timer Circuit

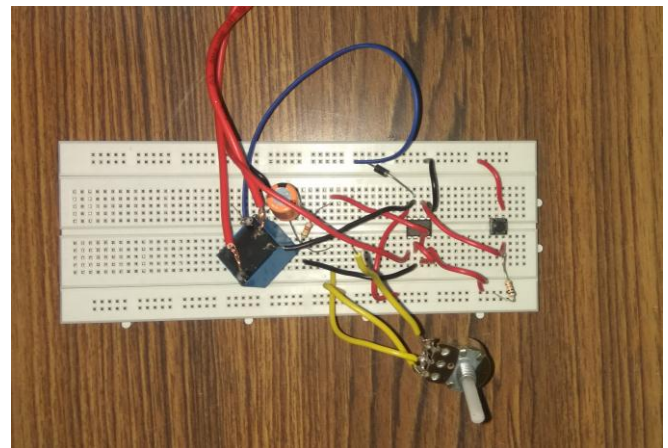

**Fig 4:** Preliminary Testing Circuit

**3.4.3 Working**

1. A push-button is used to initiate the circuit.
2. On depressing the button momentarily, a positive voltage from the supply line enters the potentiometer and switches ON the transistor and subsequently the bulb or electrical device, in the course of the above action, the capacitor also gets charged fully.
3. On releasing the push button, though the power to the base gets disconnected, the transistor continues to conduct with the aid of the stored energy in the capacitor, which now starts discharging its stored charge via the transistor. The LED also stays switched ON until the capacitor gets fully discharged.
4. The value of the capacitor determines the time delay or for how long the transistor stays in the conducting mode.

- Along with the capacitor, the value of the potentiometer also plays an important role in determining the timing for which the transistor remains switched ON after the push-button is released.



Fig 5: Working Model Top View

### 3.4.4 Results for RC-Timer

The timer for the experiment below is designed for experimental purposes. It is designed such that:

- Minimum On Delay - 1min 30 sec
- Maximum On Delay – 5min

The timer switch for practical purposes can be designed by changing R and C combinations. Using 1MΩ Potentiometer and connecting various capacitors in parallel can increase the timing. A variable capacitor can also be used like the one used in Radios to control the frequencies.

Sr.No.	Component	Power (Watts)
1	BC547 Transistor	4
2	1000 μF Capacitor	1.3
3	100K Potentiometer	0.5
4	12V Power Supply	24
5	12V SPDT Relay	120
6	1N4007 Diode	2
	<b>Rating</b>	<b>152W</b>

Table 1: Power Consumption for RC Timer

## 4. CONCLUSIONS

- The study of various electrical timers was done and RC timer was successfully designed, tested for home automation application.
- Since RC timer requires fewer components, is light-weight, cost-effective and lower power consumption. We can use it for automation for lights and mobile phones recharging.
- Industrial Timers are very costly and used in industries for automation purposes and where high voltage is required.
- PLC timers are bulky and need to be programmed.

## REFERENCES

- Himani Goyal, Understanding of IC555 Timer and IC 555 Timer Tester, International Journal of Inventive Engineering and Sciences (IJIES) ISSN: 2319-9598, Volume-3 Issue-2, January 2015.
- Robert F. Coughlin, Fredrick F. Driscoll, operational amplifiers and linear integrated circuits (Prentice-Hall electronics, 2014). R. Nicole, "Title of paper with only the first word capitalized," J. Name Stand. Abbrev., in press.
- Larson, Ron, Robert Hostetler, and Bruce Edwards. Calculus: Early Transcendental functions, New York: Houghton Mifflin Company, 2007.
- Raymond A., Serway, and John W. Jewett, Jr. Physics: for Scientist and Engineers. Belmont, Ca: David Harris, 2005.
- Paul Horowitz and Winfield Hill (1989), The Art of Electronics (Second ed.), Cambridge University Press
- Allen Bradley (2008), SLC 500 instruction set reference manual, Rockwell Automation.
- Herman, S.L. (2014), Industrial Motor Control 7th Edition, I. Clifton Park, NY: Cengage Learning.
- Frank D. Petruzella, Industrial Electronics (Basic Skills in Electricity & Electronics), McGraw-Hill Science 3rd Edition.