

DESIGN AND FABRICATION OF BATTERY OPERATED WEEDERMACHINE

Dr.V.Jayaseelan*, R.Magesh Kumar¹, M.MayaKannan²

Assistant Professor*, Department of Mechanical, Prathyusha Engineering College, Tamilnadu, India

^{1,2} Student, Department of Mechanical, Prathyusha Engineering College, Tamilnadu, India

-----***-----
Abstract - Weed is a plant that is considered undesirable in a particular situation, it is basically "a plant in the wrong place". Weeds are needed to be controlled because it reduces crop quality by contaminating the commodity. Weeds reduce farm productivity, they invade crops, smother pastures and in some cases can be harmful for the livestock. They aggressively compete for water, nutrients and sunlight, resulting in reduced crop yield and poor crop quality. Weed control is one of the most difficult tasks on an agricultural farm. Mechanical weed control is easily adopted by farmers once they get convinced of its advantages. Motorized agriculture weeding machine not only uproots the weeds between the crops rows but also keeps the soil surface loose, ensuring better soil aeration and water intake capacity. Weeding by motorized Weeder reduces the cost of labor and also saves time. In human operated Weeder, muscle power is required and so it cannot be operated for long time. The traditional method of hand weeding is time consuming. In this Battery drive motorized weeder we use motorized system, which is powered by battery.

Key Words: Weeder, Motor, Battery, Mounts and Joints

1. INTRODUCTION

Weed control is one of the most difficult tasks in agriculture that accounts for a considerable share of the cost involved in agriculture production. Farmers generally expressed their concern for the effective weed control measures to arrest the growth and propagation of weeds. In Indian agriculture, it's a very difficult task to weed out unwanted plants manually as well as using bullock operated equipment which may further lead to damage of main crops. More than 33 percent of the cost incurred in cultivation is diverted to weeding operations there by reducing the profit share of farmers. A weed is essentially any plant which grows where it is unwanted. A weed can be thought of as any plant growing in the wrong place at the wrong time and doing more harm than good (Parish, 1990). It is a plant that competes with crops for water, nutrients and light. This can reduce crop production. Some weeds have beneficial uses but not usually when they are growing among crops.

1.1 PROBLEM IDENTIFICATION

Weed removal is one of the major activities in agriculture. Chemical method of weed control is more prominent than manual and mechanical methods.

However, its adverse effects on the environment are making farmers to consider and accept mechanical methods of weed control. Chemical weeding is the most extensively used method of weed removal but these chemicals used for weeding are harmful to living organisms and toxic in nature. Research has been carried out to use some combination various methods of weeding. The need of replace the use of herbicides with more sustainable weed control techniques encouraged the definition of innovative physical weed control strategies. Mechanical and thermal means were used to control weeds and removal by mechanical method is one the methods frequently used these to remove weeds from the agricultural fields. Research has been conducted on economical methods for weed removal without damaging the crops.

1.2 EXISTING METHOD

Agriculture is the backbone of India, and weed removal being one of the primary process in the field, there is a necessity for weed to be removed in all the fields to increase the quality of crops and to decrease the effect of weeds on crops. A weed may be defined as any plant or vegetation that interferes with the objectives of farming or forestry, such as growing crops, grazing animals or cultivating forest plantations. A weed may also be defined as any plant growing where it is not wanted. For example, a plant may be valuable or useful in a garden, or on a farm or plantation but if the same plant is growing where it reduces the value of agricultural produce or spoils aesthetic or environmental values, then it is considered a weed.

2. MOTIVATION AND OBJECTIVE

The objective of the project is to design, construct and test battery operated weeder, to provide the best opportunity to farmer's to easily control and removing the weed from farm. Weeding with the use of tools like cutlass and hoe requires high labor force in a commercial farming system hence mechanical weeder is necessary to reduce the labor force. Environmental degradation and pollution caused by chemical is reduced by the use of Mechanical weeder. Low effective operation, high work effort and high time requirement for different types of hoe or cutlass, can be

overcome with the use of mechanical weeder. Presently in India, weeding with simple tools such as cutlass, hoe etc. is labor intensive and intensive and time consuming. Thus, there is a need for the design of manually operated weeder for intensive and commercial farming system in India. For this study we are developed battery operated weeder by power of wiper motor.

3. OVERALL SYSTEM ARCHITECTURE

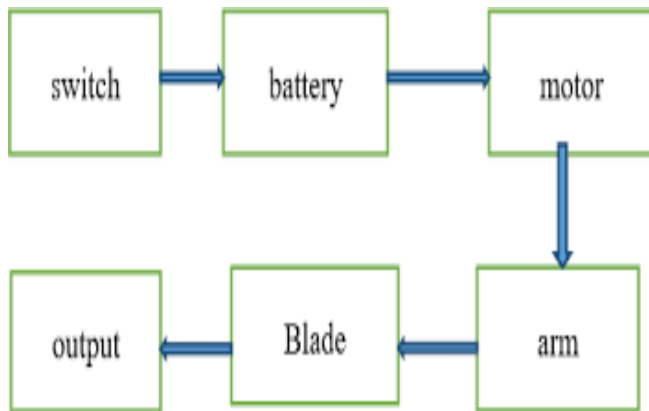

Fig -1 Block Diagram



Fig -2 Fabrication Diagram

A. BRUSHLESS DC MOTOR:



Fig 3.1 BRUSHLESS DC MOTOR

A brushless DC electric motor (BLDC motor or BL motor), also known as electronically commutated motor (ECM or EC motor) and synchronous DC motors, are synchronous motors powered by direct current (DC) electricity via an inverter or switching power supply which produces electricity in the form of alternating current (AC) to drive each phase of the motor via a closed loop controller. The controller provides pulses of current to the motor windings that control the speed and torque of the motor. The advantages of a brushless motor over brushed motors are high power-to-weight ratio, high speed, electronic control, and low maintenance. Brushless motors find applications in such places as computer peripherals (disk drives, printers), hand-held. The construction of a brushless motor system is typically similar to a permanent magnet synchronous motor (PMSM), but can also be a switched reluctance motor, or an induction (asynchronous) motor, power tools, and vehicles ranging from model aircraft to automobiles.

B. SCREWS:



Fig 3.2 SCREWS

A screw is a type of fastener, in some ways similar to a bolt (see Differentiation between bolt and screw below), typically made of metal, and characterized by a helical ridge, known as a male thread (external thread). Screws are used to fasten materials by digging in and wedging into a material when turned, while the thread cuts grooves in the fastened material that may help pull fastened materials together and prevent pull-out. There are many screws for a variety of materials; those commonly fastened by screws include wood, sheet metal, and plastic.

C. MOUNTS AND JOINTS:



Fig 3.3 MECHANICAL MONITORING MOUNT

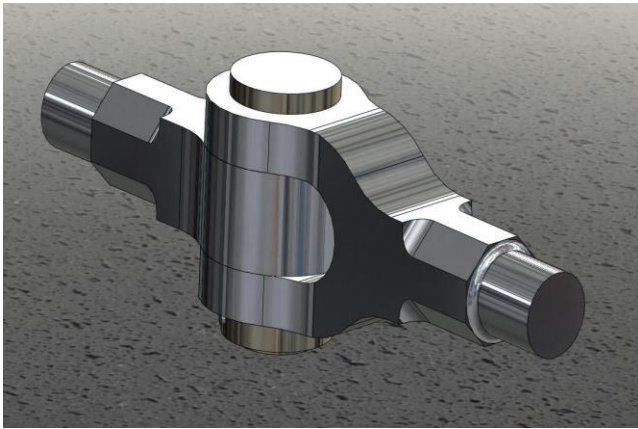

Fig 3.4 MECHANICAL JOINT

A mechanical joint is a section of a machine which is used to connect one or more mechanical part to another. Mechanical joints may be temporary or permanent, most types are designed to be disassembled. Most mechanical joints are designed to allow relative movement of these mechanical parts of the machine in one degree of freedom, and restrict movement in one or more others. Mechanical joints are much cheaper and are usually bought ready assembled. Shock mounts can be used to isolate the foundation or substrate from the dynamics of the mounted equipment. This is vital on submarines where silence is critical to mission success. Another common example of this are the motor and transmission mounts that are used in virtually every automobile manufactured today.

Without isolation mounts, the interior noise and comfort level in today's vehicles would be significantly different than what we have grown accustomed.

D. WHEELS AND RODS:



Fig 3.5 MANUAL WHEEL HOE WEEDER

In its primitive form, a wheel is a circular block of a hard and durable material at whose center has been bored a circular hole through which is placed an axle bearing about which the wheel rotates when a moment is applied

by gravity or torque to the wheel about its axis, thereby making together one of the six simple machines. When placed vertically under a load-bearing platform or case, the wheel turning on the horizontal axle makes it possible to transport heavy loads; when placed horizontally, the wheel turning on its vertical axle makes it possible to control the spinning motion used to shape materials (e.g. a potter's wheel); when mounted on a column connected to a rudder or a chassis mounted on other wheels, one can control the direction of a vessel or vehicle (e.g. a ship's wheel or steering wheel); when connected to a crank or engine, a wheel can store, release, or transmit energy.

E. BATTERY:



Fig 3.6 BATTERY

A battery is a device consisting of one or more electrochemical cells with external connections[1] for powering electrical devices such as flashlights, mobile phones, and electric cars. When a battery is supplying electric power, its positive terminal is the cathode and its negative terminal is the anode. The terminal marked negative is the source of electrons that will flow through an external electric circuit to the positive terminal. When a battery is connected to an external electric load, a redox reaction converts high-energy reactants to lower-energy products, and the free-energy difference is delivered to the external circuit as electrical energy. Historically the term "battery" specifically referred to a device composed of multiple cells, however the usage has evolved to include devices composed of a single cell. Primary (single-use or "disposable") batteries are used once and discarded, as the electrode materials are irreversibly changed during discharge; a common example is the alkaline battery used for flashlights and a multitude of portable electronic devices. Secondary (rechargeable) batteries can be discharged and recharged multiple times using an applied electric current; the original composition of the electrodes can be restored by reverse current. Examples include the lead-acid batteries used in vehicles and lithium-ion batteries used for portable electronics such as laptops and mobile phones, wristwatches to small, thin cells used in smartphonelarge lead acid batteries or lithium-ion batteries in vehicles.

4.1 CONSTRUCTION OF WEEDER MACHINE:

1. Assembly of machine consist the mounting of motor on the frame & chassis is mounted on wheel. Then the motor is assembled on chassis by using nut, bolt & somewhere by weld.

2. Manufacturing of motor includes following procedure Blades are cut by grinding cutter & Bending of blade is done manually. These blades are attached with the frame by adjusting setting.

3. Two wheels are fitted below the wiper motor. Fitted by nut & bolt

4. Square pipe is used for the handles with required dimensions & switch is fitted on handle & connected to battery by using wire.

5. Switch & electrical connections are made for on/off the engine & Switch is mounted on handle of machine.

4.2 WORKING OF WEEDER MACHINE:

1. Initially start the motor with the help of on/off switch mounted on handle. We used the wiper motor.

2. The blades are used for the forward movement of the machine.

3. Battery is used to transmit power from motor to intermediate shaft.

4. The blades are mounted on the front side of the machine. When blades start rotating forward motion occurs.

5. Hence weeding is done with less effort and less cost.

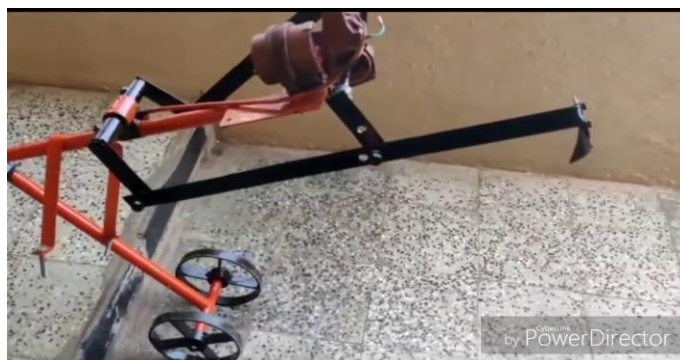

Fig 4.2 EXPERIMENTATION WORK

5. PROCEDURE:

The previous problem of agriculture weeds are that they can't be easily eliminated in the cultivated land. Because there is no special machines available in the field. The weed elimination is done by human effort. It can be reduced in our design of machine, it will minimize the human effort at low cost. The design of distance between the two wheels are adjustable with respect to our requirements. The horizontal adjustments are mainly provided for placing the blades in certain distance with one another. The blade distance mainly depends on plant size and age. The top of the wheel shaft a diesel engine is provided for rotating the blades. The distance can be adjustable but the engine is fixed at that same point of contact. The selection of diesel engine is only for load purpose. Because the rotary blades are rotated with respect to given power and speed. The soil level also decides the speed of the machine. The engine power is directly connected to the primary shaft and the primary shaft is connected to the secondary shaft. The secondary shaft is coupled with the cam shape shaft and the cam shape edges are connected with the blades. The rotary motion of cam shape shaft is transmitted to blades by using chain drives. The handles are provided for turning the direction of the machine. The forward direction movement of the machine is done on the wheel shaft is connected to the engine. The blades are rotated in clockwise direction and the weed is removed perfect to near the plant. In the design totally minimize the time of weed elimination in the field of agriculture. The small thickness of the wheels can be rotated at any plants between the cultivated lands and it is not affected the plants.

6. RESULTS AND DISCUSSIONS:

The Weed removal machine is built to be compact and efficient to cut the weeds. The machine was tested on a field to check its weeding capability and efficiency. The test results were successful as the machine performed flawlessly. It can be concluded that the machine is comparatively compact and easy to handle. This machine is able to run of field effortlessly and the efforts of farmers are reduced. The cost of weeding using this machine is considerably less as compare to manual weeding. It is reduced by 66.66% .The weeders available in market are suitable for large farms, so this can be the best machine for the farmers with small land. This semi-automatic machine is developed to reduce the time and effort required for production up to the great extent also this machine manufacturing cost is less as compared to other. By selecting above topic it was able to understand, familiar and know the details of agricultural technology, with the help of this semi-automatic machine .This is little effort to make comfort to our farmers also this machine is

Manufactured in less cost as compared to other the project also teaches the way of working as a unity proper coordination is to be established with student in the project group. It enhances the thinking or filling of mutual cooperation in the project.

7. CONCLUSIONS:

Agricultural development plays important role as a driver of rural poverty reduction. The effort required to develop a weeder will meet the demand of farmers. The efficiency of weeder should be satisfactory and it is easy to operate. It was faster than the traditional method of removing weed. Less labor needed and it is more economical than hand weeding. Here do not use any fuel and power. Hence maintenance cost is very less. Cost of weeding by this machine comes to only one-third of the corresponding cost by manual laborers. The fabrication of Low cost Weeder is done with locally available material. The overall performance of the weeder was satisfactory.

8. FUTURE WORK:

1. The weeder consists of two rotors, float, frame and handle.
2. The rotors are cone frustum in shape, smooth and serrated strips are welded on the surface along its length.
3. The rotors are mounted in tandem with opposite orientation.

9. FUTURE SCOPE:

1. If we use new material then performance will be high.
2. The farmers need alternatives for weed control due to the desire to reduce chemical use and production costs.
3. Currently no such system exists for removing weeds located in the seed line between crop plants.

10. APPLICATIONS:

1. A number of common weeding tools are designed to ease the task of removing weeds from gardens and lawns.
2. The fulcrum head weeder has a split tip like a serpent's tongue, and a long thin handle.
3. Many models have a curved piece of metal along the handle which is put against the ground while the tip is digging.

REFERENCES:

- [1] R. Yadav and S. Pund "Development and Ergonomic Evaluation of Manual Weeder". Agricultural Engineering International: the CIGRE journal, vol. 9, October 2007.
- [2] Rajasekar M, and et al, "Simulation and Analysis of Low Cost Weeder" International Journal of Research in Engineering and Technology, vol. 3, no. 3, NCRIET-2014, May-2014.
- [3] Laukik P. Raut, "Development and fabrication of agricultural pesticides sprayer with weeder," International Journal of Applied Research and Studies, vol. 2, no. 11, November 2013.
- [4] Nagesh Kumar, "Performance evaluation of weeders," International Journal of Science, Environment and Technology, vol. 3, no. 6, pp. 2160- 2165, 2014.
- [5] A. B. Tupkar, "Design Development and Fabrication of Soil Tiller and Weeder," April 2013.
- [6] S. Madhu sudhana, "Development of Double wheeled multipurpose weed remover," International Journal of Engineering Technology, Management and Applied Sciences, vol. 3, no. 2, February 2015. S. M. Pedersen, "Agricultural robots system analysis and economic feasibility," Denmark Precision Agric., vol. 7, pp. 295-308, 2006.
- [7]. Akshayshinde, AkshayPatil, SohamTirodkar, Mandar Jagtap (2017) "Solar Powered & Arduino Controlled Agrirobot IJSTE - International Journal of Science Technology & Engineering, Volume 4, Issue 5 ISSN (online): 2349-784X.
- [8]. Newton Roy Gingerich (1998) "Electric Powered Small Tractor" United States Patent, Patent Number: 5,743,347
- [9]. Stephen Heckerth (2009) "Electric Tractor" United states Patent , Patent Number: US 7828,099 B2
- [10]. Tharoon T (2017) "Design and fabrication of rotary tiller blade" IRJET volume:04 Issue:1 e-ISSN:2395-0056 ,p-ISSN: 2395-0072.