

ECO FRIENDLY TRASH ACCUMULATION SYSTEM USING IOT FOR SMART CITIES

Meghana Sambare R¹, K V Nagalakshmi², Jeyaraman³

¹Student, M.Tech-Networking and Internet Engineering, Dept. of ECE, National Institute of Engineering, Mysuru, Karnataka, India.

²Professor, Dept. of ECE, National Institute of Engineering, Mysuru, Karnataka, India.

³Trainer, Cranes Software International Limited, Bangalore, India

Abstract - Nowadays production of waste is increasing due to the rapid growth of urbanization. The overflow of waste from bins in the public places may lead to harmful diseases. Human life along with earth's environment is under threat due to increase in plastic waste of households. Most of the time road side bins are not monitored at regular basis. In this paper a new system is proposed for ecofriendly trash accumulation using IOT for smart cities. Smart cities are fusion of several IoT systems which are making human lives more pleasant and safe in all sense. Garbage monitoring is one of the effectual applications of IoT which would clinch healthy environment for creature on this earth, with significant efficiency. An automatic trash collection system is proposed in which trash from different parts of city is collected and dumped into final destination with the help of belt which drives through the motor, from that point garbage vehicle carry the waste.

Key Words: IR sensor, Garbage, GSM, Pipelines, Raspberry pi, Stepper motor, ultrasonic sensor, web server.

1. INTRODUCTION

Social relevant applications like intelligent smart systems are developed by researchers and developers using wireless sensor devices which are originated recent advancements in communication technology. One among that smart system is garbage collection system. In cities garbage has been a big problem, where overflow of garbage pictures can be seen very often. Per capita generation of waste is increasing by 1.3% per annum and 3-3.5% of urban population is increasing per annum. Currently 5% increase in waste generation is noticed annually. India produces 42.0 million tons of waste yearly at present. India is spending more money for waste management of which 30% of the amount is on transportation alone. But this can be done effectively without manual process using IoT, which is by smart trash accumulation system. There are mainly two issues which may rise with smart waste collection. First is how frequently waste is collected from dustbins and secondly how to inform municipal authorities about the status of the bins. Proposed system solves both the issues by detecting the level of waste in bin, on this basis it will send alert SMS to municipal authorities and dispose the waste.

Other features like automatic open and close of bin lid using IR sensor and motor. Raspberry-pi is used to send the information to the server. Ultra-sonic sensor is placed inside the bin to detect the level of waste in bin. Soil moisture sensor is used to check if any wet waste is present in dry waste if it is present then fine will be put to the user. Stepper motor is used inside the conveyor to carry the waste from home location to end bin location from where municipality collects the garbage. Bin status, conveyor status and wet waste detection everything will to simultaneously upload to server.

2. LITERATURE SURVEY

An efficient waste management system has become the need; there are a few systems for waste management and smart garbage bins already proposed.

[1] Proposed a system of two dustbins, bin A can be used but bin B cannot be used until bin A is full. Bin B can be used only once the bin A is full and then bin A will not open until the waste is cleared in the bin A. Whenever any of the bin is full, a message is sent to the concerned authority. Depending on the presence of an obstacle dustbins have automatically close and open feature. In our system, the garbage level in the dustbins is detected with the help of Ultrasonic Sensor and presence of the obstacle is detected by Infrared Sensors and communication to the authorized control room by GSM using GSM.

[2] System consists of sensor node, it senses bin level, reports readings and Sensor statuses using Ethernet modem from Arduino UNO. Bin door locks automatically once the bin is full and during rain. Ultrasonic Sensor checks the level of the dust bin and sends this information to its nearest corporation office.

[3] Status of dustbin will be known through Internet without physically observation of dustbins. Here one WeMos D1 mini with two ultrasonic sensors is used. Micro USB cable and smart phone is also used. Smartphone is connected wirelessly with ESP8266 to show dustbins status. Code can be burnt into board before or after circuit wiring through Arduino IDE. When code is burnt to board, it connects to hotspot and its own local IP can be seen on serial monitor.

That IP will be used to connect to this board through smart phone.

[4] Main aim of the developed method is collecting waste into the dumping vehicles. Here module placed above the dustbin will send an alert SMS to the server node whenever bin is filled to certain levels. It again sends a message to the concerned authorities from server node. Information of harmful gases inside the waste also comes to picture in this system.

[5] Provides an IoT based architectural solution to for the present waste management system. The process of tracking, collecting, and managing the waste is automated and monitored efficiently. Using sensors, data from the garbage bins is collected and send them to a gateway using LoRa technology. The data from different garbage bins are collected by the gateway and through MQTT protocol it is sent to the cloud. Long distance data transmission is enabled by data communication using LoRa technology which has low power consumption compared to Wi-Fi, Bluetooth or Zigbee.

[6] "Smart Recycle Bin" that uses RFID tags to detect the identity of the person throwing the garbage. RFID based (or any ID card based) systems are not possible to implement on a city wide scenario as it is impractical to think every individual will be carrying his RFID card at all times whenever he has to dispose some form of waste into a garbage bin. Also, their system has no provision for sending the data to the cloud.

[7] Here system uses the GSM system to send messages to the server whenever a dustbin is full. This system is impractical to use on a city wide level as assigning GSM modules and SIM cards to each garbage bin is not possible.

[8] Proposes a system uses GPRS to send the sensor data to a mobile app over the cloud. This is again not feasible as fitting GSM modules to all the dustbins of a city and ensuring that GPRS data is available to each of the bins is impractical.

3. PROPOSED SYSTEM

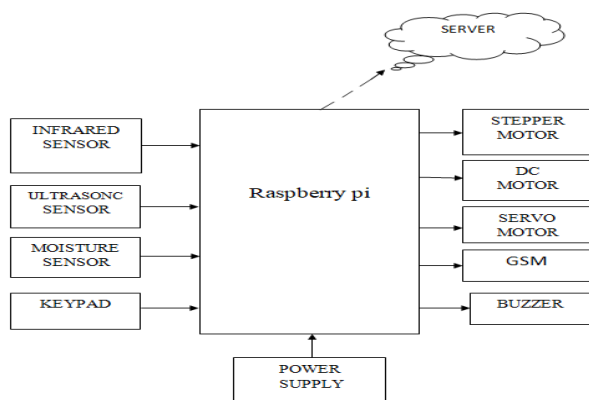

Fig.1 Block diagram of proposed system

Figure 1 describes the block diagram of the proposed system, which consists of Raspberry Pi as controller. When any person need to use the bin located near his home his mobile number should be registered with the system. Whenever the person goes near the bin IR sensor detects him and send the OTP to their registered number through GSM. When that OTP is entered through keypad dustbin lid automatically opens using dc motor. Ultra-sonic sensor is placed inside the bin that detects the level of waste if the level exceeds the threshold then the alert SMS is sent to the municipality number through GSM. Here two different bins are used, one for dry waste another for wet waste. If a user puts wet waste in dry waste bin soil moisture sensor in the bin detects the wet waste and immediately puts fine to that user number and one more moisture sensor is placed at the end of the conveyor to segregate dry and wet waste using servo motor wet waste in dry waste conveyor is sent to wet waste conveyor by motor angular rotation. Carrying of waste from home bin to end trash accumulation bin is done by using stepper motor placed inside the conveyor containing belt. When the waste from bin is dumped into the conveyor IR sensor inside conveyor detects the obstacle and makes the stepper motor to run, as long as it stop detecting obstacle stepper motor runs continuously and dumps waste to the end accumulator. Along with these functionalities some information will to simultaneously uploading to the server. Like level of the bin, wet waste detection and status of each bin along with its location. This is how proposed system works.

Results and Analysis

Some of the results are presented in the below figures. Fig. 2 shows the OTP which is required to use bin and is sent to a registered user mobile number when his appearance is sensed by IR sensor. Fig 3 shows the message sent to the authority when bin is full, this consists of location of the bin along with garbage full message. Fig 4 shows that a fine amount message sent to bin user when he/she put wet waste in dry waste bin. Simultaneously status of the bin is also uploaded to cloud. Results in cloud comes as a graph from along with the timings Fig 5 shows that and in Fig 6 shows location of the bin can be seen in cloud.

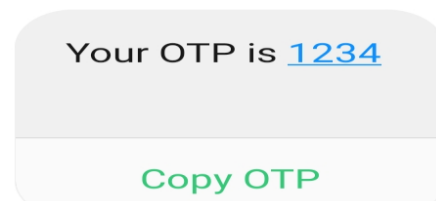

Fig. 2 OTP received

garbage is full at location <https://www.google.com/maps/search/?api=1&query=12.9814141,77.5963159>

Fig 3.Filled bin Location

Pay the Fine amount \$\$\$\$

Fig 4.Fine amount

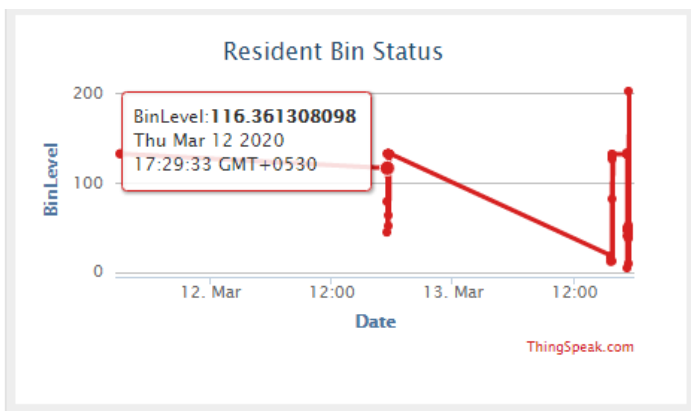

Fig. 5 Bin Status updated in cloud

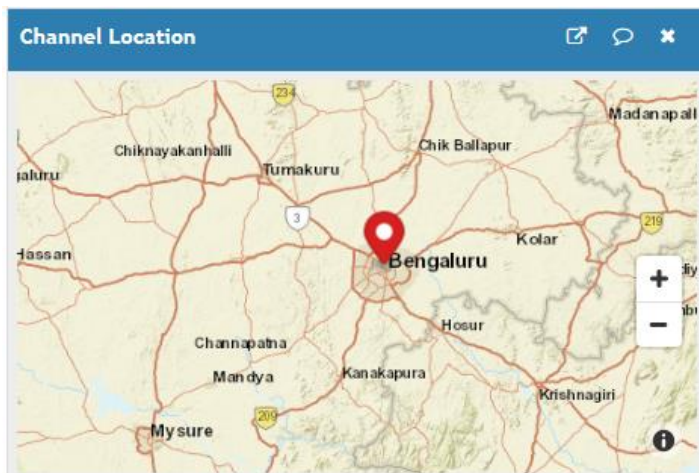

Fig. 6 Location of bin updated in cloud

3. CONCLUSIONS

This paper gives an overview of the proposed architecture and results of the work towards smart trash accumulation system. Real time reporting of level of waste from the bins

continuously and dumping it to one place without any vehicle or person involvement ensures the clean and healthy environment. In future the present model will be more user friendly and digitalized by developing mobile application and a LCD display to indicate the status of the bins.

REFERENCES

- [1] G Sai Rohit, M Bharat Chandra, Shaurabh Saha et al. "Smart Dual Dustbin Model for Waste Management in Smart Cities", 2018 3rd International Conference for Convergence in Technology (I2CT) The Gateway Hotel, XION Complex, Wakad Road, Pune, India. Apr 06-08, 2018.
- [2] Murugaanandam. S, Ganapathy. Vand Balaji. R. "Efficient IOT Based Smart Bin for Clean Environment", International Conference on Communication and Signal Processing, April 3-5, 2018, India.
- [3] Saadia Kulsoom Memon, Faisal Karim Shaikh, Naeem Ahmed Mahoto et al, "IoT based smart garbage monitoring & collection system using WeMos & Ultrasonic sensors", 2019 International Conference on Computing, Mathematics and Engineering Technologies - iCoMET 2019.
- [4] P.Siva Nagendra Reddy, R.Naresh Naik, et al, "Wireless Dust Bin Monitoring And Alert System Using Arduino", 2017 IEEE.
- [5] Abhay Shankar Bharadwaj, Rainer Rego, Anirban Chowdhury. "IoT Based Solid Waste Management System", Frugal Labs Tech Solutions Private Limited, Bengaluru, Karnataka, India, 2016 IEEE.
- [6] M. H. A. Wahab, et al., "Smart Recycle Bin: A Conceptual Approach of Smart Waste Management with Integrated Web Based System," International Conference on IT Convergence and Security (ICITCS), 2014, Beijing, 2014.
- [7] S. Thakker and R. Narayanamoorthi, "Smart and wireless waste management," International Conference on Innovations in Information, Embedded and Communication Systems (ICIIECS), 2015, Coimbatore.
- [8] C. K. M. Lee and T. Wu, "Design and development waste management system in Hong Kong," 2014 IEEE International Conference on Industrial Engineering and Engineering Management, Bandar Sunway, 2014.