

EXPERIMENTAL INVESTIGATION ON ROLLER BURNISHING OF ALUMINIUM 7075-T6 ALLOY

Srinivas Mutyala¹, Smt. K .Bhavani²

¹M. Tech Cad/Cam, Department of Mechanical Engineering, Git, Gitam University, Vizag,(A.P.)

²Assistant Professor, Department of Mechanical Engineering, Git, Gitam University, Vizag (A.P.)

ABSTRACT -The material used in this study was a commercial 7075-T6 aluminium alloy and a illuminate particle both stirred inside a stir casting machine and furnace .In this paper the methodology starts from casting of aluminium 7075 T-6 +illuminate powder, machining of casted specimens in lathe cnc machine, roller burnishing of specimens in conventional lathe machine, and finally conducted mechanical test like fatigue test, tensile test ,surface roughness , electrical conductivity. Three different% of illuminate powder 0%,5%,10%,15% by weight with respect to aluminium alloy 7075 T-6 and the following fatigue test, tensile test ,electrical conductivity, surface roughness test.

KEYWORDS : Roller burnishing, burnishing tool, CNC Lathe Machine, Hardness test, tensile strength, surface roughness test, electrical conductivity test, Heat treatment

1) INTRODUCTION

High-strength aluminium alloys, such as 7075-T6, are commonly used in many applications such as in automobile and aerospace industries due to their light weight, good combination of high strength and ductility, and corrosion resistance properties. Roller burnishing is cold working process used to improve surface structure it produces a fine surface finish by planetary rotation of hard rollers over bored or turned metal surface it compresses projection (peaks) into indentations (valleys) thus forming smooth mirror finished surface in the burnishing process at point of contact. The pressure generated by rollers exceed the yield point of material, the surface is plastically deformed by cold flowing of subsurface material the result is mirror like finish tough and hardened surface. Roller burnishing helps users to eliminate secondary operations for substantial time and cost savings, while at the same time improving the quality of their product. Roller burnishing is a method of producing an accurately sized, finely finished and densely compacted surface that resists wear. Hardened and highly polished steel rollers are brought into pressure contact with a softer work piece. As the pressure exceeds the yield point of the workpiece material, the surface is plastically deformed by cold flowing of subsurface material. A burnished surface is actually smoother than an abrasively finished surface of the same profilometer reading. Profilometers measure

roughness height. Abrasive metal removal methods lower the roughness height. But, they leave sharp projections in the contact plane of the machined surface. Roller burnishing is a metal displacement process. Microscopic “peaks” on the machined surface are caused to cold flow into the “valleys”, creating a plateau like contact plane. The burnished surface will therefore resist wear better than the abraded surface in metal to metal contact, as when a shaft is rotating in a bushing. Roller Burnishing is a Superfinishing process. Lapping and Honing is eliminated. .The pressure required for roller burnishing depends on various factors like tensile strength of the material, surface toughness before and after roller burnishing, ductility, shape of the rolls and diameters. Roller burnishing is used on cylindrical, conical, or disk shaped workpiece . The tool resembles a roller bearing, but the rollers are fixed so they slide against the workpiece surface instead of rolling. It is simultaneously rotated and pressed into the workpiece.

1.1) MATERIAL DIMENSION

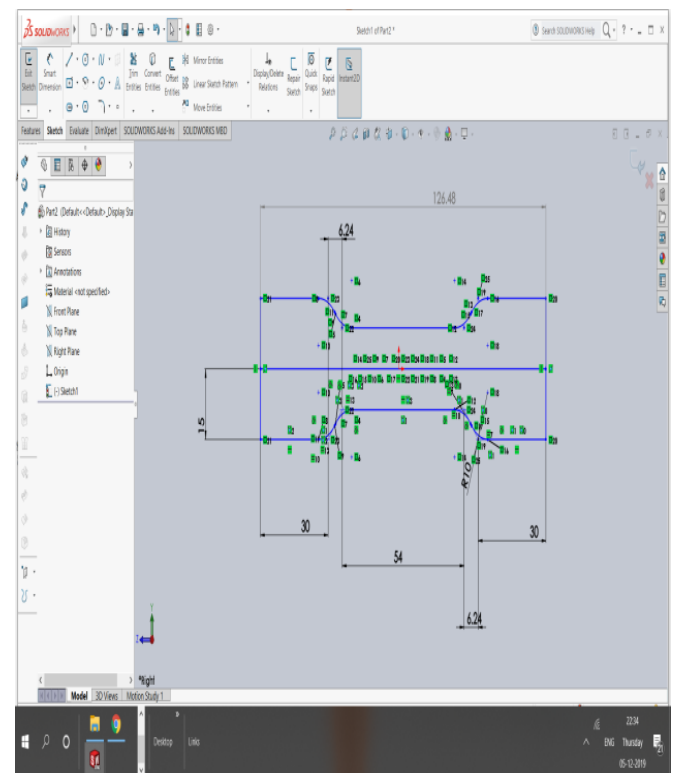

Figure (1) dimension of specimen

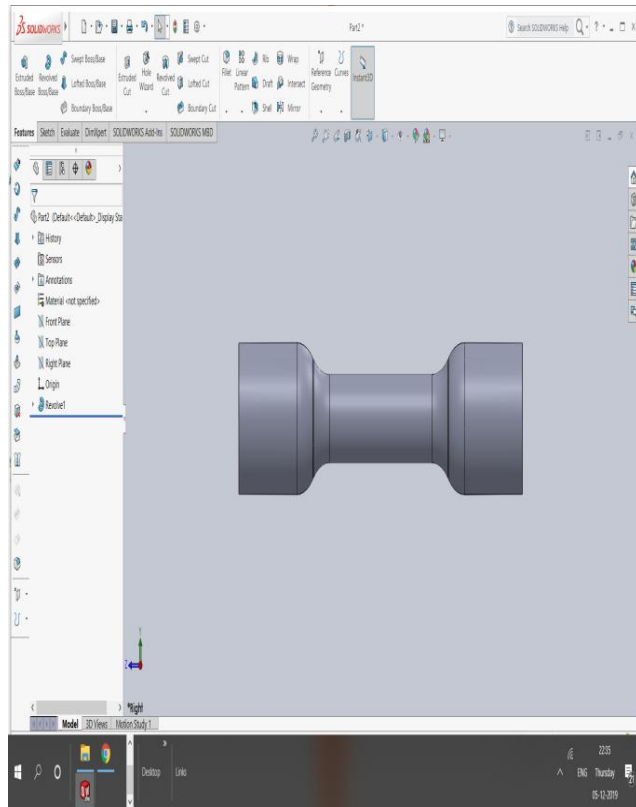
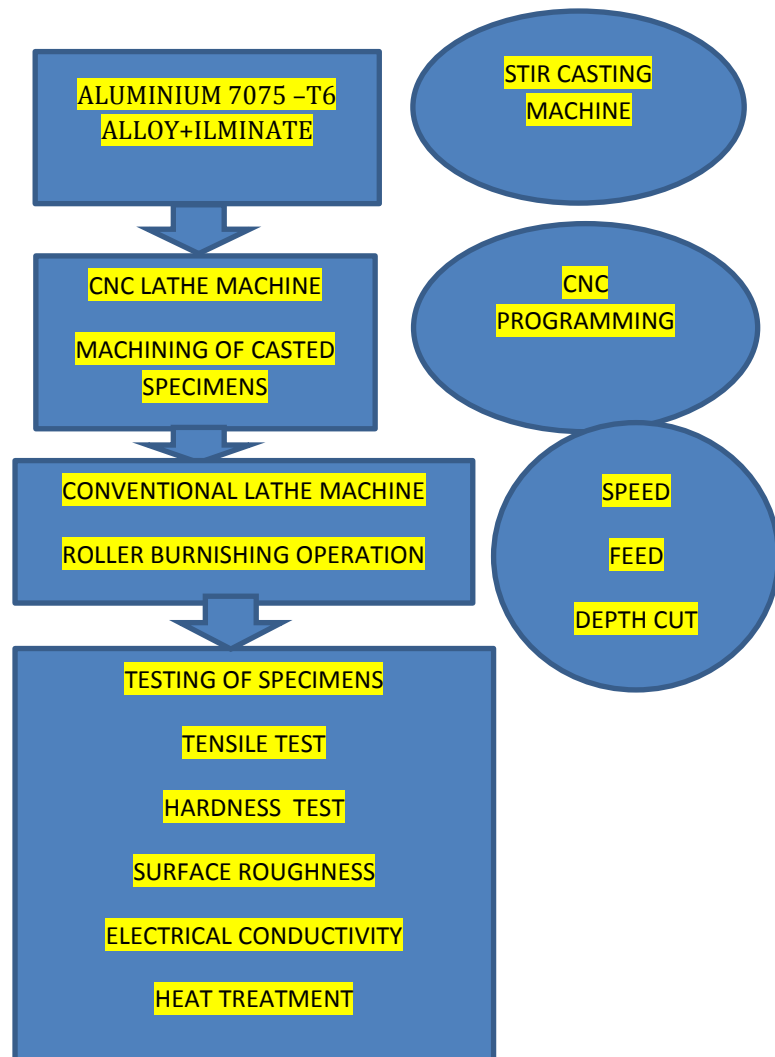

Figure (2) 3D full dimension of specimen



Figure (3) 3D view of specimen

1.2) METHODOLOGY



1.3) MICROSCOPIC VIEW

The optical microstructures the aluminium alloy composites with various wt.% of ilmenite powder (a) represents the optical micrographs of grain structure developed in the base AA7075 aluminium alloy and clearly reveals the elongated pancake shaped grains. Grain boundary precipitates (MgZn₂) are observed in all three conditions with different morphology. The microstructure reveals the grains with the presence of some intermetallics. These intermetallics have been previously identified as mainly Al₇Cu₂Fe, (Al, Cu)₆(Fe, Cu), and Mg₂Si. Fig. 4.1 (b), (c) and (d) shows the ilmenite particles in various proportions. From these micrographs it is observed that the ilmenite powder is distributed in the matrix and there exists proper bonding between matrix and ilmenite particles.

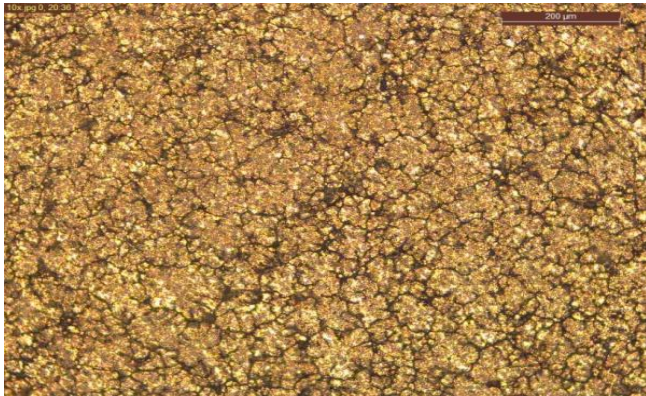

Figure (4) 0% base alloy

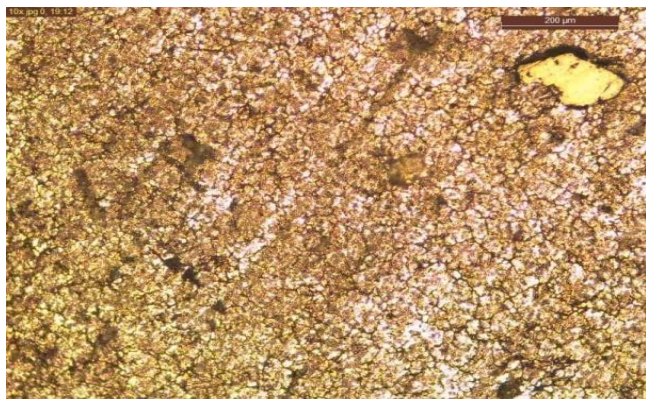

Figure (5) 5% composition



Figure (6) 10% composition

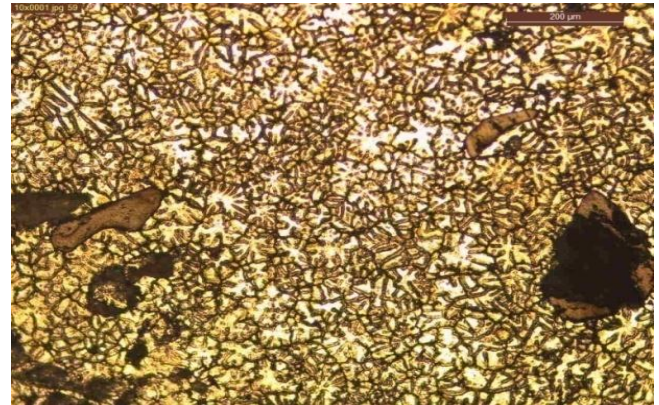

Figure (7) 15% composition

2) ROLLER BURNISHING TOOL

To keep constant force on the specimens while doing burnishing operations internal spring and clamping attachments are used.



Fig (8) roller burnishing tool

3) STIR CASTING

Aluminium 7075 -T6 alloy is mixed along with illuminate powder inside a furnace at a temperature of 900 degree Celsius both are stirred well inside a furnace with cutting blades.



Figure (9) stir casting inside a furnace



Figure (10) stirrer blade



Figure (11) casting die

3.1) CASTED SPECIMENS

After the furnace, allowing it to solidify for 45 seconds, break the mould



Figure (12) casted specimens

4) CNC MACHINE

Machining is done by using G-codes and M-codes. After casted specimens, specimens are made in to required design shape in cnc lathe by using codes.



Figure (13) cnc lathe

ROLLER BURNISHING PARAMETERS

PROCESS PARAMETERS			
LEVELS	1	2	3
SPINDLE SPEED (RPM)	450	715	1050
WORK FEED (mm/rev)	0.04	0.07	0.10
NO OF PASSES	1	2	3

Water is used as a lubricant .

Table no (1) Roller burnishing parameters

5) HARDNESS TEST

The Vickers hardness (HV) results from the quotient of the applied test force (F in newtons N) and the surface area of the residual indent on the specimen (see formula below). To calculate the surface area of the residual pyramidal indentation, the average of the two diagonals (d1 and d2 in mm) is used, because the base area of Vickers indents is frequently not exactly square. The recommended Vickers hardness range can be found in the standard (ISO 6507). Depending on the test force and specimen material used, The Vickers hardness value lies between 1 and 3.000 HV.

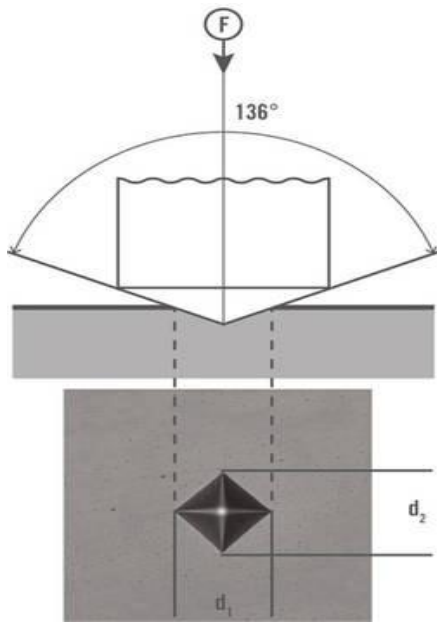

Figure (14) Vickers hardness test

The HV number is then determined by the ratio F/A , where F is the force applied to the diamond in kilograms-force and A is the surface area of the resulting indentation in square millimetres. A can be determined by the formula-

$$A = \frac{d^2}{2 \sin(136^\circ / 2)},$$

Which can be approximated by evaluating the sine term to give

$$A \approx \frac{d^2}{1.8544},$$

Where d is the average length of the diagonal left by the indenter in millimeters. Hence.

$$HV = \frac{F}{A} \approx \frac{1.8544F}{d^2} \quad [\text{kgf/mm}^2],$$

Ideally, the test force is increased from 0 to its final value within 7 seconds (minimization of measurement uncertainty). The maximum permissible interval for application time from the standard is 2 to 8 seconds (nominal time duration 7 s). Generally, the dwell time for the test force is 10 to 15 seconds (nominal time duration 14 s). If the dwell time is any longer, the duration in seconds must also be specified in the hardness value, e.g.: 610 HV 10/30 (dwell time of 30 s). The test forces used in the macro range in the Vickers method are mostly substantially smaller than those

used in the Brinell method. The preferred choice for the macro range is 49, 98, 196, 294, 490 or 980 N, with 294 N being used most frequently for testing in practice.



Figure (15) Vickers hardness test

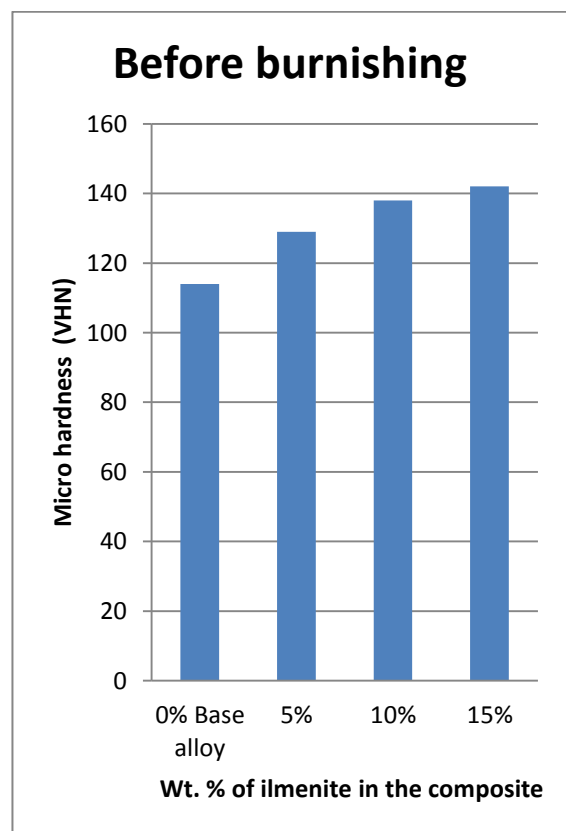

Fig (16) HARDNESS TEST RESULTS

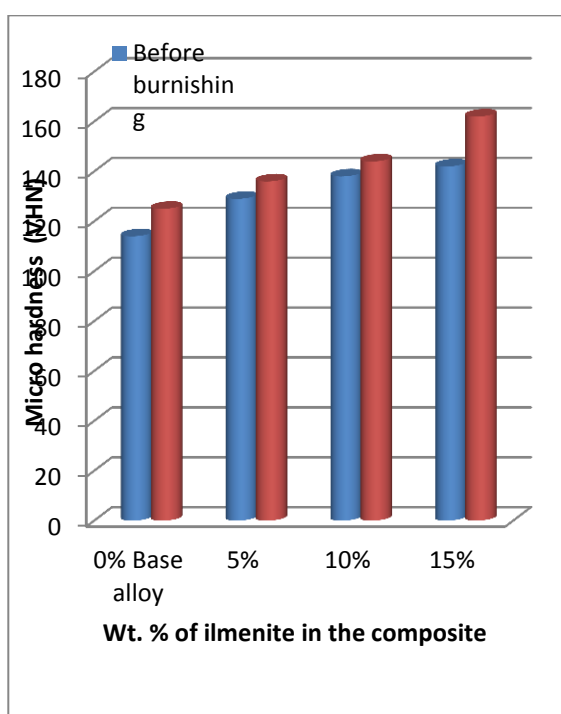

Fig (17) graph comparison before burnishing and after burnishing

It is observed that the microhardness increases with the % increase in illuminate powder .

It is observed that the microhardness increases after burnishing.

%WEIGHT OF ILLUMINATE POWDER	BEFORE BURNISHING	AFTER BURNISHING
0% BASE ALLOY	114	125
5%	129	136
10%	138	144
15%	142	162

Table (2) hardness test comparison

6) SURFACE ROUGHNESS TEST

The surface roughness values of the aluminium alloy composites with various wt. % of ilmenite powder before and after burnishing were shown in Table 4.1. The corresponding graphs of these surface roughness values were shown in Fig. 4.2. From these values and graphs it is observed that the surface roughness increases with increase in wt. % of ilmenite particles. It is also observed that the surface roughness decreases after burnishing. The more and more addition of ilmenite particles causes a surface roughness to the component.

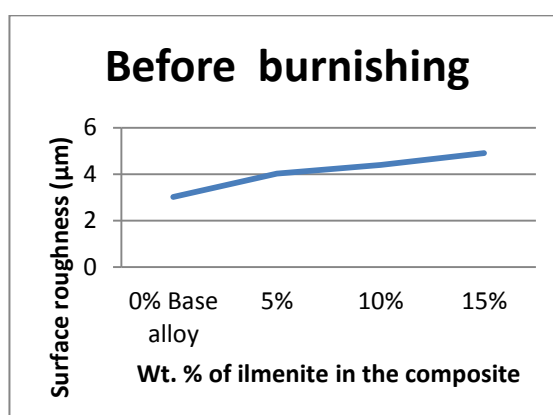

Fig (18) Before burnishing surface roughness

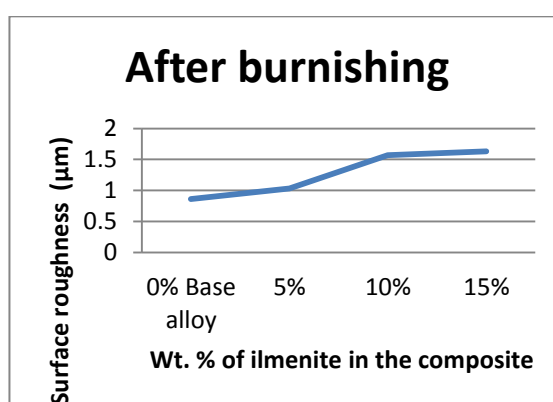

Fig (19) After burnishing surface roughness

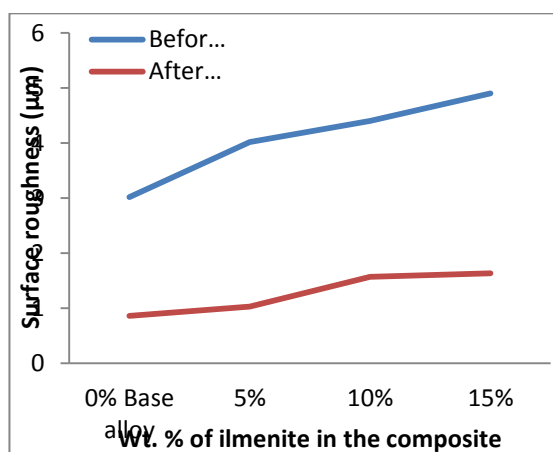

Fig (20) comparison of before and after burnishing.

It is observed that the surface roughness increases with the increase in % weight of illuminate particles. It is observed that the surface roughness decreases after burnishing.

Weight % of illuminate particles	Before burnishing	After burnishing
0%	3.02	0.86
5%	4.02	1.03
10%	4.4	1.57
15%	4.9	1.6333

Table (3) surface roughness comparison



Fig (21) tensile test specimen

7) TENSILE TEST

The engineering tensile test also known as tension test is widely used to provide basic design information on the strength of material and as an acceptance test for the specification of the materials. Tensile tests are simple, relatively inexpensive, and fully standardized. By pulling on something, it can be very quickly determined how the material will react to forces being applied Fig (13) tensile test stress strain curve in tension. As the material is being pulled, its strength along with how much it will elongate can be find out. A lot about a substance can be learned from tensile testing. As the machine continues to pull on the material until it breaks, a good, complete tensile profile is obtained. A curve will result showing how it reacted to the forces being applied. In the tensile test a specimen is subjected to a continually increasing uniaxial tensile force while simultaneous observations are made of the elongation of the specimen. Fig shows a typical stress-strain curve for a metal .For the very small strains involved in the early part of the test, the elongation of a measured length is recorded by an extensometer. The load is increased gradually, and at first the elongation and hence the strain, is proportional to the load and hence to the stress. This relation (Hooke’s Law) holds up to a value of the stress known as the limit of proportionality(Point A).Hooke’s law ceases to be obeyed this point, although the material may still be in the “elastic” state. The point B shows the elastic limit. If the material is stressed beyond this point, some plastic deformation will occur. The next important occurrence is the yield point C, at which the metal shows an appreciable strain even without further increase in load. For materials showing no definite yield, a proof stress is used to determine the onset of plastic strain. After yielding has taken place, further straining can only be achieved by increasing the load, the stress-strain curve continuing to rise up to the point D. The strain in the region from C to D is 100 times the strain the system from 0 to C, and is partly elastic (i.e. recoverable), but mainly plastic (i.e. permanent strain). At this stage (D) the bar begins to form a local “neck”, the load falling off from the maximum until fracture at the stress-strain curve deviates.

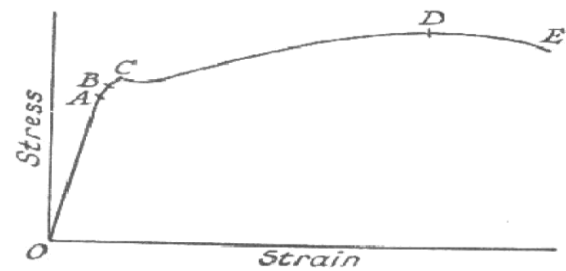

Figure (22) tensile test stress strain curve

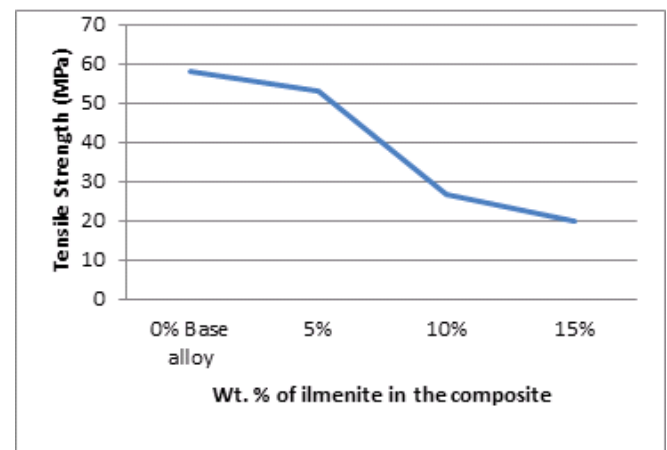

Figure (23) tensile test strength comparison



Figure (24) instron tensile testing machine

As the % weight of illuminate is increasing hardness is increasing and strength of the component goes on decreasing.

Weight % of illuminate particles	TENSILE STRENGTH IN (MPA)
0% base alloy	58.2
5%	52.9
10%	26.66
15%	19.89

Table (4) tensile test strength

8) ELECTRICAL CONDUCTIVITY TEST

The electrical conductivity values of the aluminium alloy composites with various wt. % of ilmenite powder before and after burnishing were shown in Table 4.2. From these values and graphs it is observed that the electrical conductivity increases with increase in wt. % of ilmenite particles. It is also observed that the electrical conductivity increases after burnishing.

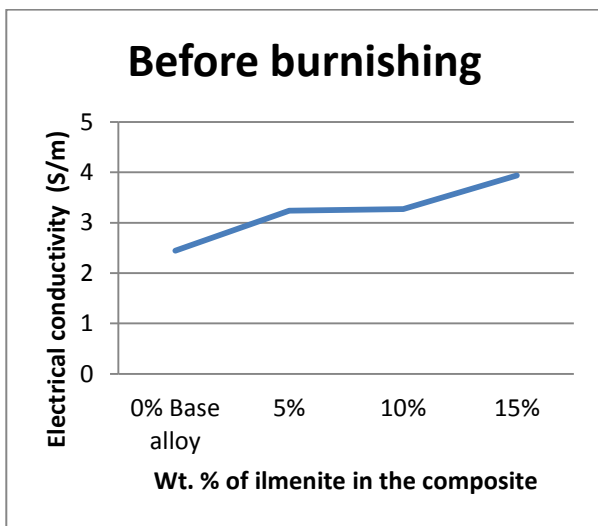

Fig (25) Before burnishing

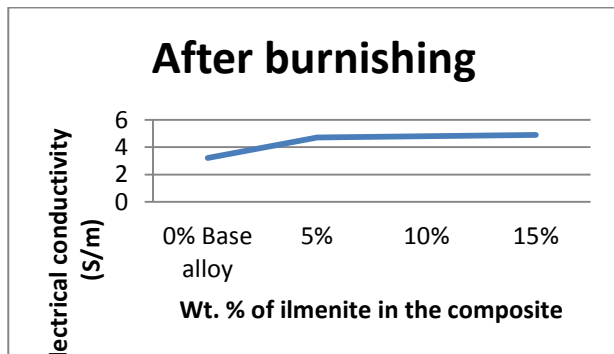

Fig (26) after burnishing

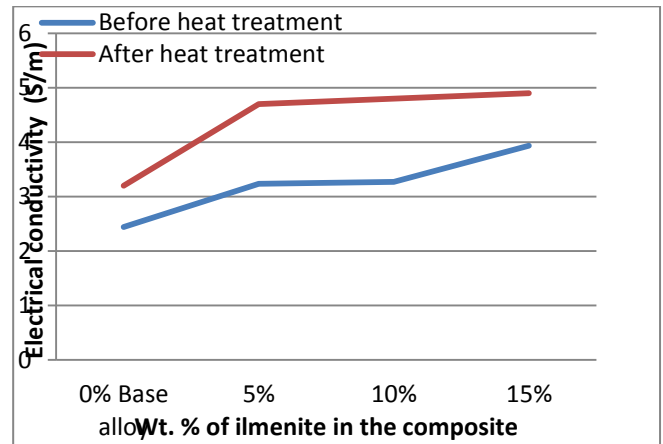

Fig (27) comparison of electrical conductivity before heat treatment and after heat treatment.

Table no (5) electrical conductivity comparison

Wt. % of ilmenite in the composite	Before burnishing	After burnishing
0% Base alloy	2.444	3.205
5%	3.236	3.771
10%	3.27	4.716
15%	3.94	4.901

9) CONCLUSIONS

The Metal Matrix Composite of Al alloy 7075 and Ilmenite has been subjected to experimentation and the data so obtained from the tests has been evaluated. Hence, based on the obtained results we can infer the following conclusions:

- 1) By using stir casting method defect free castings were obtained.
- 2) From the microstructures of all the specimens it is observed that there is uniform distribution of reinforcement particles in all specimen.
- 3) An increase in Hardness was observed in the specimens with reinforcement of ilmenite when compared with the base metal. It is attributed to the uniform distribution of ilmenite particles as observed in the microscopic images.
- 4) The surface roughness was observed to be more with addition of ilmenite particles and the surface roughness decreased after the burnishing process.
- 5) There appears an increase in electrical conductivity with the addition of ilmenite particles and minute increment after the burnishing process.

10) REFERENCES

1. Ajay Dev Boyina, M.VijayaSekharBabu, K.SantaRao and Dr. P.S.Rao, "Investigation of Mechanical Behaviour of Ilmenite Based on AL Metal Matrix Particulate Composites", Journal of Department of Mechanical Engineering, GMRIT.
2. Rasidhar, Dr. A. Rama Krishna and Dr. Ch. SrinivasRao, "Fabrication and Investigation on Properties of Ilmenite (FeTiO₃) based Al-Nanocomposite by Stir Casting Process", International Journal of Bio-Science and Bio-Technology, Vol. 5, No. 4, August, 2013.
3. RajeshkumarGangaramBhandare and Parshuram M. Sonawane, "Preparation of Aluminium Matrix Composite by using Stir Casting Method & it's Characterization", Pune University, Sinhgad Academy of Engineering, Pune, Maharashtra, Special Issue-3, (April 2014).
4. Tools for roller burnishing, deep rolling, forming", Prospectus, Ecoroll A.G. Werkzeugtechnik, 2000.
5. M.A. Baghchesara P, H. Abdizadeh., "Hardness and Tensile Strength of Fractography of stir casted AL-ZRO₂ composites 1 Alloy Matrix Composites: Comparative Study" International Journal of Mining, Metallurgy & Mechanical Engineering (IJMME) Volume 1, Issue 1 (2013) ISSN 2320-4060.
6. S. Suresh N. Shenbaga Vinayaga Moorthi "process development in stir casting and investigation on microstructures and wear behavior of TiB₂ on Al6061 MMC" Procedia Engineering 64 (2013) 1183 - 1190.
7. SN Prashant, Madev Nagral, V Auradi, Preparation And Evaluation Of Mechanical And Wear Properties Of Al6061 Reinforced With Graphite And Sic Particulate Metal Matrix Composites, International journal of mechanical engineering and robotics research, (2012/10), 106-112.
8. Avinash Kumar and Singh, Satyajeet (2011) Wear Property of Metal Matrix Composite. BTech thesis, Wear Property of Metal Matrix Composite, Department of Metallurgical and Materials Engineering, Issue 2013.
9. Hosur Nanjireddy Reddappa, Kitakanur Ramareddy Suresh, Hollakere Basavaraj Niranjana, Kestur Gundappa Satyanarayana, "Studies on Mechanical and Wear Properties of Al6061/Beryl Composites", Journal of Minerals and Materials Characterization and Engineering, 2012, 11, 704-708.
10. Johny James.Sa, Venkatesan.Kb, Kuppan.Pc, Ramanujam.R, "Hybrid Aluminium Metal Matrix Composite Reinforced With SiC and TiB₂", Procedia Engineering 97 (2014) 1018 - 1026.
11. David Raja Selvam. J, Robinson Smart. D.S. Dinaharan, "Synthesis and characterization of Al6061-Fly Ashp-SiCp composites by stir casting and compocasting methods". Energy Procedia vol. 34, 637 - 646, 2013.
12. H. R. EZATPOUR, M. TORABI-PARIZI , S. A. SAJJADI, "Microstructure