

Design and Fabrication of Semi-Automatic Road Stud Installation Machine

Prof. Shashi Kant Tripathi¹, Smit Kansagara², Jogu Abhishek³,
Darshan Devalpalli⁴, Danish Shaikh⁵

¹Assistant Professor, Department of Mechanical Engineering, Indus University, Ahmedabad, India

²⁻⁵Students, Dept. of Mechanical Engineering, Indus University, Ahmedabad, India

Abstract: - In today's automation world, there is huge demand in road reflector studs to be fixed in road for the purpose of safety. However, majority of the installation work to fix the stud is done manually, to overcome the problem of manual work and decrease the operation time by making the whole process automatic with minimum interfere of human by improving the developed machine on the bases of stability, mechanism, and machining accuracy, overall. In this research paper we have reviewed various recent research papers related to the efficient road reflector stud's installation process. We have explained our work on design and fabrication of semi-automatic road stud installation machine. At the end of the work we have suggested further improvement that could be done to make it more effective through future scope of work.

1.0 INTRODUCTION

Nowadays increase in demand of good communication between cities, large construction of road become the necessary aspect along with safety, which is accomplished by road reflector studs, commonly known as cat eye. [1] Road studs are retro reflective surface, helping visibility at night. It has been reported that with the help studs, road accidents are reduced largely. To install the cat eye on the asphalt, surface no current economic system that is being developed for automating the installation of the reflector stud on to the road, thus manual effort is fully utilized for it. As per present scenario in the market there is a huge amount of labor shortage problems and road construction is one of them, were labor is must needed. Also, manual installation process takes more time and is not efficient. To overcome the problem, aim is to design and fabricate a semi-automated road reflector stud's installation machine. By the development of this system in real time there will be huge increase in productivity of road construction works and reduces the dependability in workers of construction field.

1.1 OBJECTIVES OF THE STUDY

- 1) Studying the existing machine to improve machinability and developed fully electric power system instead of pneumatic.
- 2) Fabricating a compact and stiffer machine at economical cost.

- 3) To design different components of machine.
- 4) Testing the model under different conditions of speed and surfaces.

1.2 LITERATURE REVIEWS

[2] K.S. Hanumanth Ramji, S. Suresh, M. Samuel Nixon, S. Babari Rajan worked to design an automatic road stud installation machine and pavement marking machine. In this system model machine is working on four stages of stud installation process and separated pavement marking process by the expansion of the cylinder on the head of spray. Thus, to accumulate all the process except drilling station, they placed four working station on rotating spindle which increases the complexity of machine and effected the overall stiffness of the machine. Thus, due to the two types of operation which is not always required, makes machine bulky and decrease the effectiveness of portability.

[3] R. Deepak Kumar, S. Pradeep, M. Navin Prasad, and S. Shankar had worked on making the road reflector stud installation pneumatic machine. The model machine which is developed uses the pneumatic cylinder for the stamping of the stud on road surface and also for the glue pouring process for stud fixing. While, the cleaning of the hole is done by the pneumatic jet. Thus, there is the requirement of the air compressor of 10 to 15 bar pressure capacity, which is placed in machine structure or external supply is needed, so it becomes lack of convenient to use as a portable installation machine.

[4] Vishvajit Sudhakar Phake, Aditya Prabhakar, Rushikash Sonawane, Akshay Hari, worked to design and development of intelligent braking system with the help of ratchet and pawl mechanism. In this system ratchet and pawl mechanism is used to restrict backward motion of the vehicle at slope by just fixing ratchet on wheel axial and pawl with frame with respect to front wheel. Thus, as per above work they are successful to handle the huge weight by simple ratchet and pawl mechanism, which can be successfully used in our model by replacing ratchet with rack to eliminate backward motion of drill during drill hole and can be reposition by just detaching it from rack, Hence this mechanism is effective and economical to use, where good strength is required to handle back pressure of concrete drill machine.

[5] The surface roughness plays important role in the drilling operation for the selection of the components. The surface roughness increases by increase of cutting speed and feed rate and by same rate of cutting parameter with increase in point angle, surface roughness decreases (Erol Kilickap et al 2010).

[6] The forward feed rate is also responsible for the surface roughness with spindle speed and drill diameter of the drilling machine. By using the lower tool diameter, decreases the surface roughness value and by bigger diameter it increases the roughness value because it cut more material with large chip. The diameter accuracy of the hole to be drill as per the requirement, it will vary from actual drill diameter. The hole diameter accuracy is important factor, when product is to be manufactured have to work in a precise manner or when a small part is to drill, where micro mm difference matters. However, the feed rate is most important factor for the hole diameter accuracy other than any cutting parameters. (Mustafa Kurt et al 2009).

1.3 ADVANTAGES

- It increases the productivity of work.
- It is Semi-Automatic; thus, it reduces human efforts.
- By implementing the machine in road construction industry, it reduces cost of labour.
- Better accuracy and cleanliness of operation.
- Reduces the workers fatigue by making simple to operate.
- Enough storage for raw materials, which eliminate a large amount of material handling.

1.4 LIMITATION

- It required variation in speed (RPM) for a different surface of working.
- It can only fix one stud at a time.
- Stability of machine depends on the working surface.
- For different size studs it required modification.
- For drilling and machine forward movement it needed manual work.

1.5 APPLICATION

- The originally machine is made to install studs that separate lanes or the middle of the road.
- It is also capable to fix studs on concrete surface, normally found in parking area to differentiate the parking space with a vehicle path.
- Machine also applicable to install studs, where the sand block is used.
- At the zebra crossing machine can effectively use.

2.0 METHODOLOGY

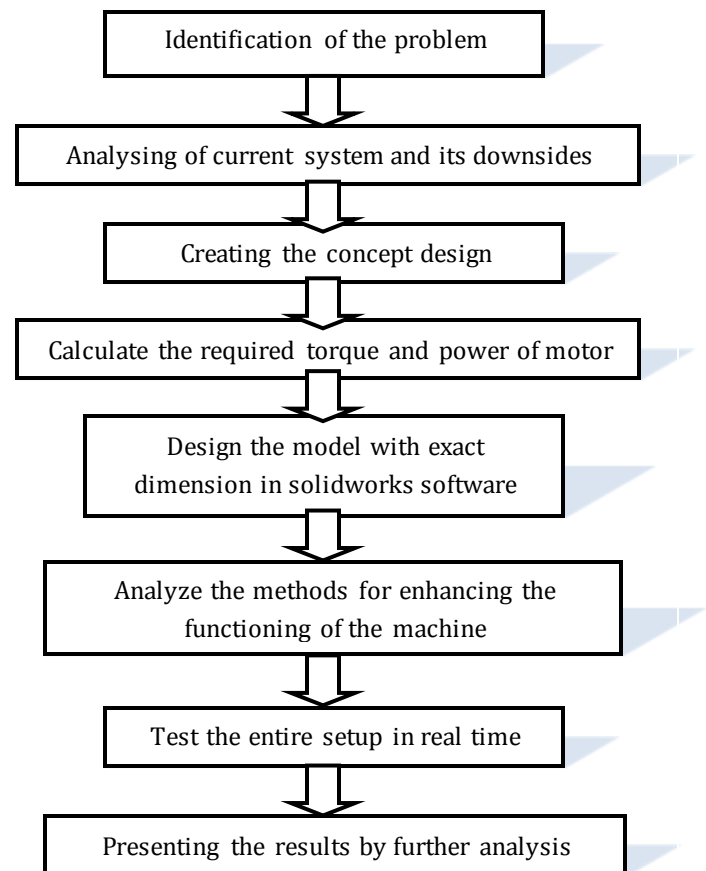

3. COMPONENTS OF MACHINE

Table-1: Parts of the machine

COMPONENTS	Material	Quantity
Frame	Mild Steel	1
Drill motor	750W-850RPM	1
Drill Bit	HSS	1
Rack	Mild Steel	1
Pawl	Mild Steel	1
Shaft	MS -IS2062	2
Hooper	MS-IS2062	1
Body cover	Aluminum	1
Blower	500W	1
Electric GlueInjector	Alloy Steel	1
Pressure Roller	Plastic	1
Roller wheel	Steel-Plastic	4
Bearing	Carbon Steel	4
Bearing housing	Cast Iron	4
Nuts and bolts	Mild Steel	-

4. CALCULATIONS

Design of various parts is described below: -

4.1 Motor Calculations: -

Motor requirements: - 720W, 900RPM max speed

Cutting Speed (Vc)

Vc (m/min): -Cutting Speed

DC (mm): - Drill Diameter = 35 mm

Π: - 3.14

N: - Main Axis Spindle Speed = 850 rpm

$$Vc = \pi \times DC \times n \div 1000$$

$$= 3.14 \times 35 \times 850 \div 1000$$

$$= 93.415 \text{ m/min}$$

Feed of the main spindle (Vf)

Fr(mm/rev): - Feed per Revolution = 0.35 mm/rev.

N: -Main Axis Spindle Speed = 850 rpm

$$Vf = fr \times n$$

$$= 0.35 \times 850$$

$$= 297.5 \text{ mm/min}$$

Drilling time (Tc)

Hole Depth = 20 mm

Feed per Revolution = 0.35 mm/rev

Number of Holes = 1 hole

$$Tc = (ld \times i) \div (Fr \times N)$$

$$= (20 \times 1) \div (0.35 \times 850)$$

$$= 0.067 \times 60$$

$$= 4.02 \text{ sec}$$

4.2 Drill Torque: -

$$Mc = 1.125 \times 30 \times 1000 / 3.14 \times 850$$

$$= 13.769 \text{ Nm}$$

4.3 Frame Dimensions: -

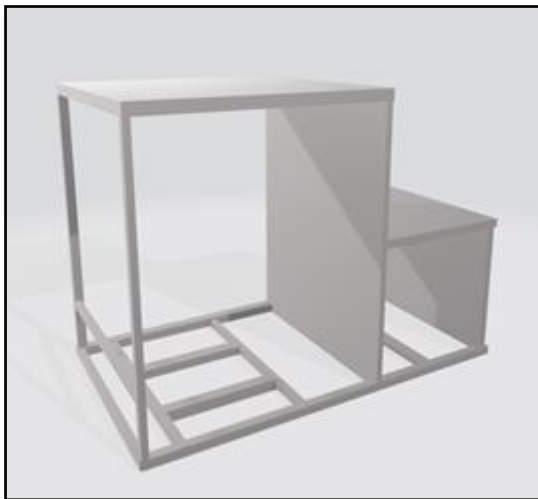

Fig-1: Frame of the machine

Made with Mild Steel (MS) L-Type angle

Height: - 830mm (32.6")

Length: - 1220mm(48")

Width: - 610mm (24")

4.4 Installation Rate: -

Total Drilling time = 4sec + Allowance (5sec.)
= 9sec.

Glue Pouring time = 6sec.

Stud placing time = 9sec.

Stud press time = 4sec.

Total tie = 28sec. + Miscellaneous factors
= 41sec. average

Rate of Installation = 10 studs per 9mins.
(With repositioning allowance)

4.5 Rack and Pawl Specifications: -

Rack

Angle of teeth = 60°

Material = S45C

Tooth hardness = 50 ~ 60HRC

No. of teeth = 100

Face width = 12mm

Total length = 12 mm

Depth of teeth = 1.6mm

Allowable torque = 39.4 Nm

Pawl

Angle of teeth = 60°

Material = S45C

Heat treatment = Induction hardened teeth

Tooth hardness = 50 ~ 60HRC

4.6 Hooper Specifications: -

140mmx 140mm upper side dimensions

130mmx 120mm main dimensions

5. DIFFERENT VIEWS OF MACHINE

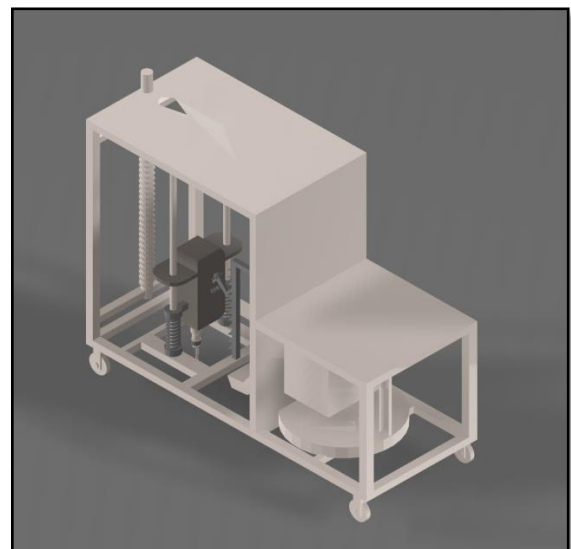

Fig-2: Isometric view of machine

This is the isometric view of or machine in which every part of the machine is visible along with frame.

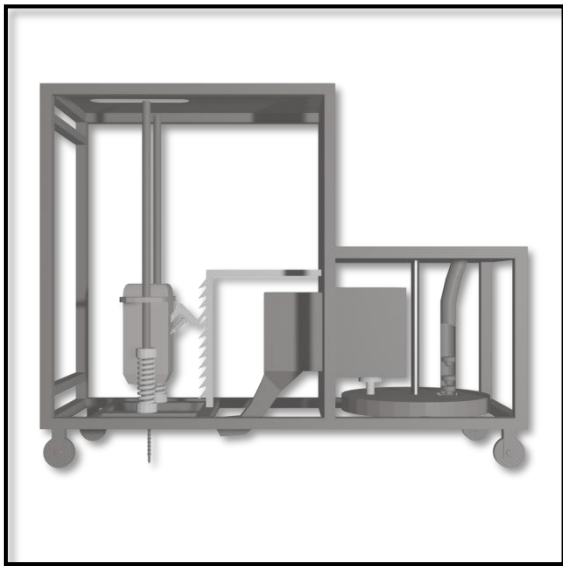

Fig-3: Side view of machine

This is the side view of our machine in which a drilling mechanism, blower glue injector, hopper for studs and whole frame.



Fig-4: Front view of machine

This is the front view of the machine, where two guide ways on which drill machine is fixed and machine rolling wheel with clearance is visible.

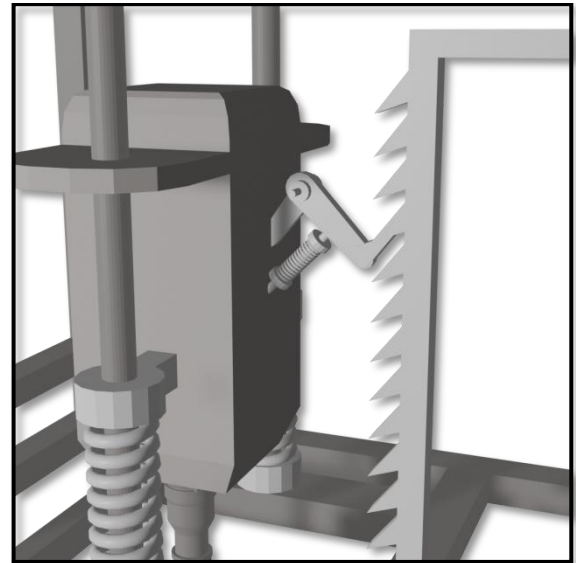

Fig-5: Assembly of drilling mechanism

This is the main drill mechanism, supported by two guide ways with springs at end. On right of drill machine rack and pawl setup is visible.

6. RESULT COMPARISON

Table-2: Comparison of Results

Parameter	Conventional method	Semi-Automated	Truck mount Machine
Size	Individual equipment	Compact	Large
Labour requirement	2-3	1	2
Time for installation	90 sec approx.	40 sec Max	30 sec approx.
Costing of installation	Higher	Low	Low
Maintenance	Low	Low	High
Quality of work	Depends on labours skill	High	High
Labour fatigue	High	Minimum	Minimum
Cost of machine	Low	Relatively Low	High

7. CONCLUSION

Through this work, we can conclude that changing the structural design and mechanism (i.e. aiding Rack and Pawl mechanism and doing other considerable changes) has improved the functional outcome from the machine and it became semiautomatic. Since all four processes (drilling, glue pouring, stud placing and stud punching/pressing) are being performed on a single machine so a single user can operate the machine in cost effective way, hence:

- Labor cost has been reduced.
- Operation time, machine changing time has been reduced.
- System became more compact and no need to carry different machines for separate purpose.
- Productivity and safety of the machine has been improved.
- Reliability and accuracy of the machine has been improved.

[7] A text book of Design of Machine Elements by V.B. Bhandari. (McGraw Hill Publication, 2003 Edition)

[8] A text book of Machine Design by R.S. Khurmi and J.K. Gupta. (S. Chand Publication, 2005 Edition)

8. FUTURE SCOPE OF WORK

In future following changes may be done to make it better for the purpose.

- To make marking on road, electric spray can be installed combine with stud installation.
- By adding Vacuum cleaning system, it is possible to clean all the dust from the road.
- By adding a road marking follow sensor, it can be made totally automatic guided machine.
- Installing odometer, this will help to fix studs at proper and accurate gaps.
- Modifying the studs Hooper, with the adjustable studs holding and placing system, it is possible to install the variety of stud's size.
- By further complex analysis, it can be possible to make all the operation at one stop of machine.
- In future, by adding chargeable battery of the 30W, machine can be made self-powered.
- If machine can be driven by motor power, by which an operator can operate machine by riding on it.

REFERENCES

[1] Article titled "Method of road stud's installation" by Nokin road stud light website.

[2] K.S. Hanumanth Ramji, S. Suresh, M. Samuel Nixon, S. Babari Rajan, Design and Fabricated Automatic Road Reflector Installation Machine and Pavement Marking Machine, IJSRD, January 2018.

[3] R. Deepak Kumar, S. Pradeep, M. Navin Prasad, and Shankar S, Design and Fabricated Semi-Automatic Road Reflector Installation Machine, IOSR e-ISSN: 2278-1684.

[4] Vishvajit Sudhakar Phake, Aditya Prabhakar, Rushikash Sonawane, Akshay Hari, Design and Development of intelligent Braking, May 2017.

[5] Erol Kilickap, "Optimization of drilling parameters on surface roughness", International Journal of Advanced Manufacturing Technology, 2010.

[6] Mustafa Kurt, Optimization of cutting parameters for surface finish and hole diameter accuracy in dry drilling processes, International Journal of Advanced Manufacturing Technology, 2009.