

Wireless Head Motion Controlled Wheel Chair for Disabled People

Ch.Rajesh Babu*, k.Yamini¹, Ch.Manikanta², K.Hemanth Kumar³, V.D.Surya Sainath⁴

*Assistant Professor, Department of ECE, Godavari Institute of Engineering and Technology, Rajahmundry, Andhra Pradesh, India

^{1,2,3,4} Student, Department of ECE, Godavari Institute of Engineering and Technology, Rajahmundry, Andhra Pradesh, India

Abstract: This paper discusses an indigenously built hand-free wheelchair for visually impaired persons. The proposed system is based on a Head Motion Recognition technique using an Acceleration Sensor. Conventional physical wheelchairs are generally powered by joysticks or hand gesture devices that can not address the needs of an almost entirely disabled adult who has limited limb movements and can barely move or turn his head. The acceleration sensor is used for head gesture recognition and the Zigbee module is used for smart wireless control. Through the adjustment of the head motion, the information goes wirelessly to the microcontroller dependent motor driving circuit to control the rotation of the Wheel Chair in five different modes, including FRONT, BACK, RIGHT, LEFT and a special STAND locking device. The proposed system is assembled using components obtained from the local market and checked in the laboratory for efficient performance, the test results are included in this article.

Key Words: Arduino Board, Head Motion Recognition, Intelligent Wheel Chair, Arm-free Control, Acceleration Sensor, Zigbee Module.

1. INTRODUCTION

About 650 million people are physically disabled in the world today. It is also very important to develop a service in order to make their lives comfortable and more versatile. Quadriplegics are individuals who are unable to control all of the extremities. The causes behind these decreased mobility possibilities may be different: diabetes, arthritis, elevated blood pressure, bone and joint degenerative disorders, and cases of paralysis and birth defects. Quadriplegia also occurs as a result of events or age. Patients with these extreme disabilities are unable to practice their daily tasks, such as: having eaten, use of toilets and moving across space. Depending on the extent of the injury, a patient can maintain freedom of mobility at a certain point by using various medical devices[1]. Mobility has been very important to a decent quality of life. The creation of an autonomous mobility program for these people with disabilities is our goal in this project.

This machine is an automated head tilt movement powered wheelchair that could be driven in either direction by means of head motions, i.e. Forward, Reverse, Left, Right. This paper describes a microcontroller device that allows the normal electrical operation of the wheelchair by head motion. The proposal defines a wheelchair designed for physically impaired persons using a head gesture and an accelerometer system that is interfaced with DC motors. The Accelerometer Sensor is a Micro Electro Mechanical Sensor that can be used to effectively translate head motion into computer-interpreted signals. The accelerometer data is measured and optimized for motion detection. Accelerometers can measure the magnitude and direction of gravity in addition to the acceleration induced by movement. Two DC Motors are used for this project. The DC motor produces a torque directly from the DC power supplied to the generator by means of internal coupling, fixed permanent magnets, and revolving magnetic magnets, the battery. The Arduino is programmed with the help of the built-in C instructions.

The prototype of the wheel chair is built using arduino, chosen for its low cost, in addition to its flexibility and efficiency in mathematical operations and connectivity with other electronic devices. The facility has been designed and applied in a smart way so that, if our property is sold, vulnerable clients in developed countries will benefit from it. We trust our project to do some good research and to make some advances in creativity, and most importantly, this will provide some assistance to the vulnerable person.

2. LITERATURE REVIEW

A literature review is an objective news, informative overview of existing scientific literature related to the topic under consideration for study. The goal is to raise awareness of current thought and work on a specific topic and can support potential study on a historically overlooked or under-studied field.

[1] According to the founder, Dr. Ibrahim Patel, a wheelchair concept. This computer system is used to power a wheel chair by removing challenges to the wheel chair regulation

by means of a joystick conversation. Full system analysis aims to solve the situations by means of a hierarchical semi-autonomous management technique. Initially, the moment-based feedback and the turn power. Allocation of direction of wheelchair movement by venue. Smart wheelchair frame design is caring for extreme motor disabilities and the wheelchair has two manual and semi-automatic modes of operation. Manual switch operation is the change mode. In future research, we will test the program with more supporters in order to achieve overall system efficiency.

[2] According to the creator, Dr. Richard C. Simpson, a wheelchair concept. The goal of the research is to establish and test a stability testing framework that would direct and promote the modification of wheelchairs to the characteristics and lifestyle of individual needs. The system assesses the center of gravity and stability and the angles of tapping. This calculations are transmitted through a portable Wi-Fi communication tablet where the stability is measured. Such principles are tested via a tech lab-based check to assess the validity of the data obtained. ISO 7176 is a set of guidelines used by wheelchair manufacturers to collect and distribute safety information on their wheelchairs. ISO 7176-2 addresses the dynamic stability of the electric wheelchair and the recommended test when driving. And this paper presented a novel concept for the stability assessment of wheelchairs, informed by the user and market analysis.

[3] According to the founder, Dr. Stewart James Hildebrand, a wheelchair project. A brief survey of research on the development of autonomy in wheelchairs is presented, and AAI's R&D for the construction of a series of intelligent autonomous wheelchairs is discussed. A modular autonomy control system that can be mounted on widely accessible power chairs that have been well constructed over the years has been developed and tested. A behavior-based approach was used to create adequate on-board flexibility at reduced cost and material usage, thus ensuring high performance, adequate protection, consistency of appearance and capacity building. To date, the add-on system has been installed and tested on two common wheelchair power models. The initial findings are very promising.

[4] According to the author, Dr. Ralf Hotchkiss, a wheelchair project. This literature deals with the different control mechanisms used in powered wheelchairs for the use of people with disabilities. The control system is based on various criteria that are complicated for a impaired person, such as motion control, brain control, speech control, etc. This research is based on the type of control mechanism used by the patient in the electric wheelchair. The report

further disputes that no procedure is suitable for all forms of physical illness. Controls often rely on the environment; voice control cannot be used in noisy environments. The multiple control system introduced in a wheelchair is ideal for addressing these drawbacks.

3. SYSTEM ARCHITECTURE

The core idea for this Head Movement wheelchair is the movement detection of the Accelerometer sensors, the accelerometer sensor is placed in the ear piece to track the rotation of the head in both axes. We use and operate the electric wheel chair using the Arduino microcontroller. The system used in this Head Motion Control Wheelchair is split into two parts. One is a transmitting hand and the other is a receiver. The transmitter side consists primarily of three parts Arduino Nano, flex sensors and a remote transmitter. In this Head motion operated wheelchair, we control the forward, backward, left and right movement of the wheelchair. The accelerometer must give the x and y coordinates to the Arduino microcontroller. This micro controller reads the obtained signal and, as per the provided code, the wheelchair is connected to the L293D module and is connected to the engines. When the accelerometer sensors are shifted in their respective x, y, z direction, the engines will be activated in that direction. If a person tilts his head in the right or left direction above, the chair shifts in the right or left direction.

The machine will operate with the Accelerometer sensors, the Arduino uno, the Zigbee board, and the feedback will be supplied to the engine drivers to raise the performance power to push the engines, and the engines will make the device travel in the desired direction.

3.1 Section of Transmitter

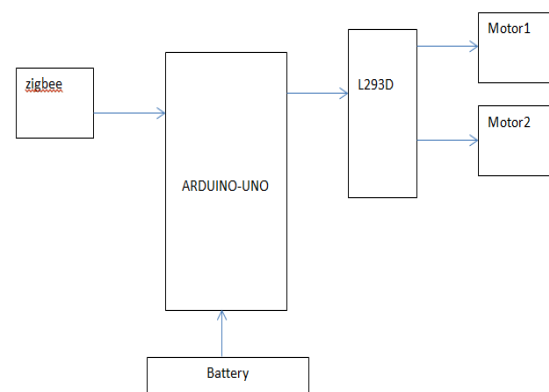

Fig -1: Section of Transmitter

Here, the transmitter block diagram depicts the activity of the transmitter circuit. The first details is given for the specific movement of the head, which is the data of the accelerometer. This data is sent to the microcontroller to make a decision as preprogrammed. The required instructions are then sent as data by the Zigbee transmitter.

3.2 Section of Receiver

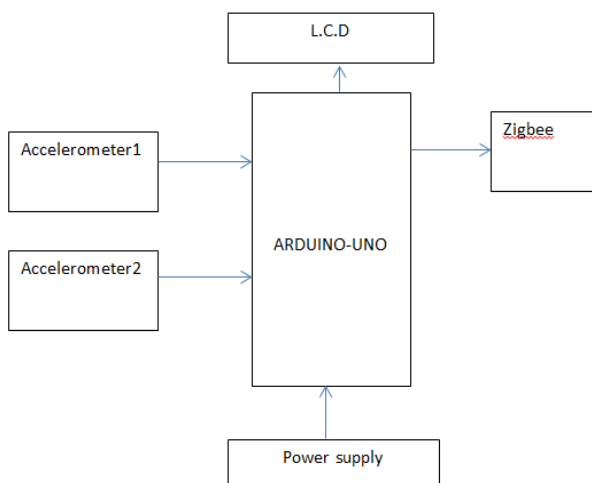

Fig -2: Section of Receiver

The diagram below illustrates the wheelchair power technique. The data transmitted by the transmitter portion is processed by the Zigbee receiver and sent to the microcontroller. The microcontroller must then take the decision because it is pre-programmed to monitor both the motor and the wheelchair route. Motor 1 and Motor 2 was added to explain the course of change in direction.

4. DESCRIPTION OF HARDWARE COMPONENTS

4.1 Arduino UNO

The Arduino Uno is an open-source microcontroller board built on the Microchip ATmega328P microcontroller created by Arduino.cc. The board is equipped with a set of digital and analog input / output (I / O) pins that can be connected to various expansion boards (shields) and other circuits. The board has 14 digital I / O pins (six capable of PWM output), 6 analog I / O pins, and is programmable with the Arduino IDE (Integrated Development Environment) with a USB type B cable. It can be operated by a USB cable or an external 9-volt battery, even though it allows voltages between 7 and 20 volts. It's similar to Arduino Nano and Leonardo, too.



Fig -3: Arduino UNO

4.2 Accelerometers

The accelerometer is an electromechanical system that tests the powers of acceleration. These forces may be static, such as the constant force of gravity pulling at your feet, or they may be dynamic, caused by the movement or vibration of the accelerometer. The accelerometer is a device that measures the vibration or acceleration of the motion of the structure. The force induced by vibration or by a shift of motion (acceleration) allows the mass to "squeeze" the piezoelectric substance that generates an electrical charge that is equal to the force applied on it. Because the charge is equal to the force and the mass is a constant, the charge is therefore proportional to the acceleration.

4.3 Zigbee Module



Fig -4: Zigbee Module

Nowadays zigbee is becoming very widely known for wireless applications with low data rate. Zigbee communication is specially designed for IEEE 802.15.4 control and sensor networks for wireless personal area networks (WPANs) and is a product of Zigbee Alliance. This integration model describes the physical and media access

control (MAC) layers to accommodate multiple devices at low data levels. This Zigbee WPANs run at 868 MHz, 902-928 MHz and 2.4 GHz frequencies. The data rate of 250 kbps is ideally adapted for both regular and intermediate two-way data transfer between sensors and controllers. The configuration of the Zigbee network comprises of three separate categories of equipment, such as the Zigbee supervisor, the Router and the End unit. Growing Zigbee network will consist of at least one coordinator serving as the root and bridge of the network.

4.4 L293D MOTOR DRIVER IC

Standard DC gear head motors require a current of more than 250mA. There are other embedded circuits such as ATmega16 Microcontroller, 555 IC timer. But this volume of current cannot be supplied by the IC 74 sequence. If the engine is directly attached to the above ICs, it may be affected. L293D IC is a standard Motor Driver IC that enables the DC motor to travel in either direction. This IC consists of 16 pins which are used to power a group of two DC motors instantaneously in either direction. This means that we can control two DC motors using the L293D IC. As well, this IC can drive small, quiet, large motors.

4.5 DC MOTOR

Nearly any technological invention we see around us is done by an electric motor. Electrical machines are a way of transforming electricity. Motors absorb electrical energy and generate mechanical energy. Electric motors are used to drive hundreds of machines that we encounter in daily life. Electric motors are usually divided into two separate categories: direct current (DC) motor and alternating current (AC) motor. The DC-operated electric motor is called the DC-motor. This is a tool that transforms electrical DC energy into mechanical energy.

5. RESULTS

Each part, as mentioned above, has been checked separately for proper functionality in the laboratory. Then all the components are put together and a prototype of the proposed wheel chair is made. The transmitter is fitted in a cap that is placed on the operator's head.

As the rider puts his head back, the wheelchair goes on. By pushing the head forward, the seat shifts backwards. If the operator's head is turned automatically, the wheelchair switches to the right. Likewise, to incline the head to the west, the wheelchair switches straight.



Fig -5: Results

6. CONCLUSION

The Head Control Assist Device was built with the goal of helping high-level Quadriplegia impaired individuals. The motion-based wheelchair is equipped with two Arduino processors and is powered by left, right, forward and backward motions. In comparison to the conventional system, the new approach is effective in moving disabled people without any mistake. Automated wheelchairs may be used to assist those with disabilities, and the new research is intended to support disabled individuals who can just lift their head to assist them move about. In the present function, the wireless device has been successfully built to push the wheel chair in various ways, i.e. forward, back, left and right, or remain in the same place and even quit automatically when the consumer needs to.

Wireless communication between the transmitter, which is placed on the head (cap) and the receiver, allows it very easy and convenient to use. Local development of the proposed wheelchair could be a successful substitute of the imported one and could be a great benefit to elderly people in our country.

7. FUTURE SCOPE

Structured wheelchairs can be extended using sun-powered boards that are increasingly productive. The Sun driven board activates the wheelchair itself. Yet only the drawback is set up by the stand, and the total weight of the chair would rise. This system can be further applied to the Speech Recognition Module to monitor the pace and orientation of the wheelchair, to detect barriers on the pathway and to regulate the direction of travel using an ultrasound sensor.

REFERENCES

- [1] International Journal of Advanced Research in Electronics and Communication Engineering (IJARECE) Volume 2, Issue 4, April 201
- [2] The development and testing of a system for wheelchair stability measurement. Medical engineering and physics. Sep. 2015. 3
- [3] Development of smart wheelchair system for a user with severe motor impairment international symposium on intelligent sensors 2012 in iris.
- [4] Review on various control system for electric wheelchair for physical handicapped people. SJIF 4.72-2017 March.
- [5] U. Cortés, C. Urdiales, R. Annicchiarico, C. Barrué, A.B. Martinez, C. Caltagirone: Assistive Wheelchair Navigation: A Cognitive View, Studies in Computational Intelligence Advanced Computational Intelligence Paradigms in Healthcare – 1, Vol. 48, 2007, pp. 165 – 187.
- [6] www.engineersgarage.com/electronic_circuits.
- [7] "Working Principle Of Arduino And Using It As A Tool For Study And Research" by L.Louis, IJCACS, Vol.1, No.2, April 2016, pp.21-29
- [8] "Automatic wheelchair for physically disabled persons" by Prof. R.S.Nipankar, V. Gaikwad, C. Choudhari, R. Gosavi, V.Harne, IJARECE, Volume 2, Issue 4, April 2013, ISSN: 2278 – 909X, pp.466-474.