

PHONE CONTROL LOAD MANAGEMENT SYSTEM

M.SAIKUMAR¹, K.SAI KIRAN², B.PRIYANKA³, MRS VINEETHA⁴

¹Students, B. Tech IV year, ²Associate Professor

^{1,2}Department of Electronics and Communication Engineering, Sreenidhi Institute of Science and Technology, Hyderabad, Telangana, India.

ABSTRACT: Smart metering is a major development in utility industries today especially the electricity industries. However, many benefits of smart metering have not been fully explored due to the limited functions of many prepaid meters that have been implemented so far in most developing countries. With the spread of internet use and web based application [1], there is the need to focus on how prepaid meters can be aided to stay online through Mobile Communication Systems [2] available in most developing countries. In this paper, design of Smart Energy Meter was achieved with Atmel microcontroller as the main part for evaluating consumed electric power and Power Factor (PF). ADE7756 metering IC is used as input unit as it contains voltage and current transformer. The root mean square (rms) value of voltage and current, consumed electric power, and PF will be monitored through LCD at customers premise and these parameters also are sent through a GSM wireless network to the base station in order to articulate consumed electrical power fees and also evaluate and monitor electric power consumption and demand.

Keyword: smart meter, load control, GSM module, Automatic Meter Reading (AMR)

1. INTRODUCTION

The development of digital information has led the rapid change in human lifestyle. The use of electricity is very important as one of the main source of energy that is vital in today modern life. Some kinds of mechanism using available technology could be used to reduce wastage in electricity usage. Thus a prototype based on a microcontroller device using SMS is developed. It can automatically control any electrical equipment at home remotely using mobile phone. Hence the electrical energy saving in daily life can be made more efficient and effective. As the technology grows, SMS technology has been widely accepted as a part of medium of communication [1]. The purpose of using SMS is to provide widest coverage at minimal cost. Therefore the use of SMS would facilitate in controlling the electrical device at home from long distance and low in maintenance and independent from any physical geographical boundary. At the present time, people use electrical energy as one of the main source of power of energy to operate any electrical device or appliance. Most of the people turn on the light for 24 hours per day when they are away from home. Leaving the light turned on continuously, lead to energy waste.

Thus this project is proposed to develop a system is to facilitate the home owner to optimize usage of electricity remotely using SMS. Light turned on continuously and it lead to energy waste. Thus this research is carried out to provide a mechanism through the development of a prototype to provide a service to the home owner to optimize the usage of electricity through remote control using SMS services.

2. RELATED WORK

The concept of this project is to control electrical load from a remote area using a mobile phone. The commands entered from the phone controls respective load using DTMF technology. The proposed system uses a mobile phone duly interfaced to Arduino. When any button is pressed from the sender mobile, the mobile generates a particular tone at the same time this tone is heard at the other end of the receiving mobile phone attached to the circuit.

By using a GSM modem, where the loads can be controlled by sending an SMS. The project works on the principle of DTMF tone command so received from any phone to remotely switch any electrical load such as agricultural pump, domestic and industrial loads etc.

3. PROPOSED SYSTEM AND IMPLEMENTATION

The methodology adopted in this work follows a structured design process that requires a systematic approach with intelligently guided computer simulations and testing. Incremental prototyping approach is used in the implementation of hardware which entails the development of a particular hardware unit on a breadboard, testing and evaluating the performance of that unit to verify its workability before moving on to the development of other units. After the development of the various units, the units are then integrated and then further tested based on predetermined test criteria to ascertain the system's workability before the final packaging. This approach is however carried out after all the necessary circuit designs have been done and

simulated on a computer.

The system is made of various units chiefly the metering unit, the controlling unit, the communication unit and the load unit (Figure 1)

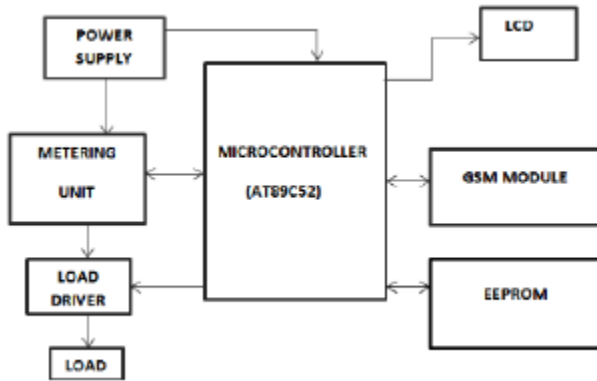

Figure 1: Smart energy metering system Architecture As shown in figure 1,

The system comprises the communication, display, control, and metering units.

The microcontroller is the control unit, assemble language was used in programming the AT89C52 microcontroller, the communication unit is the GSM module, GSM Modules are similar to modems, but A GSM/GPRS Modem is an external equipment, whereas the GSM Module is a module that can be integrated within an equipment. It is an embedded piece of hardware. The microcontroller uses AT commands to control the GSM Module. GSM Modules support an extended set of AT commands. These extended AT commands are defined in the GSM standards

Power supply circuit is built to supply the power or voltage to the circuit. For this project, the circuit needs only 5V voltage supply. Input supply for this circuit consists of 9V battery. Therefore Voltage regulator is used to provide 5V DC regulated voltage from the unregulated 9V input voltage. LM7805 is used as the voltage regulator for the circuit. The LM7805 is chosen to filter the 5V voltage for the circuits. A voltage regulator is an electrical regulator designed to automatically maintain a constant voltage level. Hence, two capacitors are used to stabilize the voltage supply and to reduce the ripples of the voltage source. The power supply circuit is shown in Figure 3

only 5V voltage supply. Input supply for this circuit

consists of 9V battery. Therefore Voltage regulator is used to provide 5V DC regulated voltage from the unregulated 9V input voltage. LM7805 is used as the voltage regulator for the circuit. The LM7805 is chosen to filter the 5V voltage for the circuits. A voltage regulator is an electrical regulator designed to automatically maintain a constant voltage level. Hence, two capacitors are used to stabilize the voltage supply and to reduce the ripples of the voltage source. The power supply circuit is shown in Figure 3

Power supply circuit is built to supply the power or voltage to the circuit. For this project, the circuit needs only 5V voltage supply. Input supply for this circuit consists of 9V battery. Therefore Voltage regulator is used to provide 5V DC regulated voltage from the unregulated 9V input voltage. LM7805 is used as the voltage regulator for the circuit. The LM7805 is chosen to filter the 5V voltage for the circuits. A voltage regulator is an electrical regulator designed to automatically maintain a constant voltage level. Hence, two capacitors are used to stabilize the voltage supply and to reduce the ripples of the voltage source. The power supply circuit is shown in Figure 3

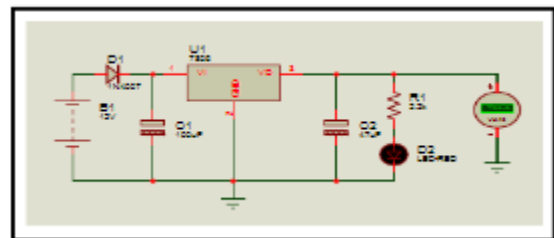

Power supply circuit

Relay is used in the circuit because it is an electrical operated switch that connected to the output. A relay in this system is an electrical switch that opens and closes under the control of PIC16F873A microcontroller. The relay switch connections are usually labeled as Common (COM), Normally Closed (NC) and Normally Open (NO). The circuit is connected to COM and NO if it is switched to ON when relay coil in ON while to switch OFF the circuit connect the COM and NC together and then the relay coil is in OFF state. Therefore, the output was connected to COM and NO. As a result the relay contacts when it detect signal from the PIC circuit. Figure 5 shows the relay that has been used for this project. This relay needs 9 Vdc supply for the coil voltage

RESULTS AND CONCLUSION

Smart metering is obviously the way forward in the pursuit of power efficiency on the part of the power companies as well as their consumers. This work described the design and development of Smart Energy metering system for load control. One of the main achievements of this work is the development, using local and available materials, of a smart energy meter. This affords for it to be an economical alternative to its more expensive counterparts in the market. It employs the utilization of a communication channel (GSM) which has the most spread especially in developing countries like Nigeria, thus not requiring an additional setting up of communication infrastructures as is the case with other communication channels like Zigbee, Wifi, PLC etc. The work also provides an efficient means of energy management and conservation as the load can be controlled remotely. It also provides an easy and convenient way of acquiring meter readings (Automatic meter readings) hence ensuring accuracy, lower operational cost and removal of possible corruption and fraud related to meter reading and revenue collection.

References

- [1] National Communications Authority. NCA (Annual Report 2008). Accra, Ghana: s.n., 2008.
- [2] Graeme Gooday. The morals of measurement: accuracy, irony, and trust in late Victorian electrical practice, Cambridge University Press, 2004 ISBN 0-521-43098-4, p 232-241
- [3] Minnkota E.G. Power's Load Management System, accessed 22 August 2009.
- [4] Yuvraj, A.; Weng, T and Gupta, R. K.San Diego, La Jolla, Micro-Systems Driving Smart Energy Metering in Smart Grids. CA USA : Dac.Com Knowledge Center Article, 2010, Dac.Com Knowledge Center Article.
- [5] Botswana Power Cooperation
http://www.bpc.bw/latest_news02.php.
<http://www.bpc.bw>. [Online] Botswana Power Cooperation. [Cited: January 25th, 2012.]
- [6] Jehl, F. Menlo Park Reminiscences.. Menlo Park Reminiscences. s.l. Kessinger Publishing, 1941.
- [7] Federal Energy Regulatory Commission, USA. Staff Report. <http://www.ferc.gov/legal/staff-reports/12-08-demand-response.pdf>. <http://www.ferc.gov>. [Online] Federal Energy Regulatory Commission, December 2008. [Cited: December 17, 2011.]
- [8] Nations, Daniel
http://webtrends.about.com/od/webapplications/a/web_application.htm. <http://webtrends.about.com>. [Online] About.com, March 2011, (Cited: December 17, 2011)
- [9] E. Moni Silviya, K.Meena Vinodhini, Salai Thillai Thilagam.J , 'GSM Based Automatic Energy Meter System with Instant Billing'. Final year Students, Department of Electronics and Communication Engineering, Aarupadai Veedu Institute of Technology, Vinayaka Missions University, Paiyanoor Chennai 603 104, India.
- [10] Mr.Rahul Ganesh Sarangle, Prof.Dr.Uday Pandit Khot, Prof. Jayen Modi, 'Gsm Based Power Meter Reading And Control System' Post Graduate Student, Associate professor and HOD Assistant professor (M.E.EXTC) EXTC Dept of Thadomal Sahani (EXTC dept) Vidyalankar college of College of engineering , Bandra Vidyalankar college of Engineering , Wadala.
- [11] Dr. Khalid H. Qamar, Engr. Mazhar Iqbal, Hassan Qayyum, M. Shahan Qadri, M. Hammad 'GSM based Automatic Energy Meter Reading'.